

Metal Studio 2

Program for drawing metal structures

User manual

(Build 2004)

Contents

1. INTRODUCTION	6
1.1 Needed computer configuration	6
1.2 Program installation.....	6
1.2.1 Individual program installation	6
1.2.2 Network installation	15
1.3 Starting the program	20
1.4 The basic concept of the program	21
1.5 3D Modeling	24
1.6 Symbols used in the program.....	28
2. ASSEMBLY POSITIONS	31
2.1 Assembly positions	31
3. GIRDERS	33
3.1 New girder in plan view	33
3.2 New girder in cross section	37
3.3 Existing girder	38
4. PLATES.....	43
4.1 New plate in plan view	43
4.2 New plate in cross section.....	45
4.3 Plate forming.....	49
4.4 Existing plate.....	51
4.5 Bended plate	54
4.6 Web stiffening	55
5. FORMING GIRDERS AND PLATES.....	58
5.1 Forming girder ends.....	58
5.2 Assigning the girder cutting plane	59
5.3 Forming a joint at an angle of two girders	60
5.4 Assigning a hole in a girder or plate	60
5.5 Subtraction at the place of penetration with another entity	62
5.6 Girder dividing	62
5.7 Editing formings.....	62
5.8 Alteration of the plate contour	64

6. CONNECTING DEVICES	65
6.1 Bolt series.....	65
6.2 New weld - label	71
6.3 New weld – symbol in plan view	75
6.4 New weld – symbol in cross section.....	78
6.5 Labeling an existing weld symbol	79
6.6 Copying the connections.....	80
7. REFERENCES	82
7.1 Labeling a girder or a plate	82
7.2 Bolts label	83
7.3 Arbitrary label.....	85
7.4 Elevation label	86
7.5 Cross-section pursuit	88
7.6 2D Cutout	91
7.7 Section symbol	92
8. EDITING ENTITIES.....	94
8.1 Database of positions.....	94
8.2 ‘Editing entities’ command	100
8.2.1 Editing girders and girder plan views	100
8.2.2 Editing plates.....	103
8.2.3 Editing labels	105
8.2.4 Editing section symbol	106
8.3 Editing bolt series.....	107
8.4 Entities alignment	108
8.5 Position and assembly change	110
9. ADJUSTING THE ENTITY LAYOUT	113
9.1 Scale factor change	113
9.2 Refreshing visibility	114
9.3 Entity layout.....	114
9.4 Configurations of the entities layouts.....	118
9.5 Adjusting the visibility of the ‘Metal Studio’ entities (VISIBILITY).....	120
9.6 Switching 2D and 3D views.....	122
9.7 Drawing frame.....	124

10. CREATING DATABASES USED BY THE PROGRAM IN ITS OPERATION.....	126
10.1 Database of shapes	126
10.2 Database of bolts	131
10.3 Database of predefined bolt lengths	134
10.4 Database of structure materials	135
10.5 Database of bolt materials	136
10.6 Database of arbitrary cross sections	136
10.7 Setting profiles colors	140
11. WORKSHOP DRAWING	144
11.1 Girder workshop drawing.....	144
11.2 Plate workshop drawing.....	152
11.3 Workshop drawings of the entire assembly	153
12. CUSTOMIZING PARAMETERS USED BY THE PROGRAM IN ITS OPERATION.....	157
12.1 Adjusting colors and fonts for the 'Metal Studio' entities (DRAWING PARAMETERS).....	157
12.2 Defining the labeling styles of the 'Metal Studio' entities (LABELING STYLES).....	160
12.3 Functionality.....	163
12.4 Adjusting the scale of the drawing.....	169
13. REPORT	170
13.1 Preview and scope of the report.....	171
13.2 Report formatting.....	173
13.2.1 Page setup	175
13.2.2 Margins	176
13.2.3 Header	177
13.2.4 Text.....	180
13.2.5 Girders and plates - specification	181
13.2.6 Shapes - recapitulation	186
13.2.7 Plates - recapitulation	188
13.2.8 Overall recapitulation	189
13.2.9 Bolts recapitulation by assemblies	191
13.2.10 Bolts recapitulation.....	192
13.2.11 Recapitulation of the washers	193
13.2.12 Auxiliary table.....	194

13.3	Printing of the report	196
13.4	Export into drawing	197
13.5	Export to RTF	197
13.6	Returning to the drawing window	198
13.7	Overall recapitulation	198
13.8	Grouping of assemblies	200
14.	IMPORT GEOMETRY FROM 'TOWER'	202
14.1	Export to 'Metal Studio'	202
14.2	Import to 'Metal Studio'	203
15.	COMPLEX ELEMENTS	206
15.1	Lateral connection of I-shape beams	206
15.2	Column beam connection.....	211
15.3	Column base	219
15.4	Beam to beam splice.....	227
15.5	Edit of complex elements.....	232
16.	3D MODELING - VIEWPORTS AND VIEWS	234
16.1	Assigning Viewports (AutoCAD's Viewports command).....	234
16.2	Change of operating mode: 3D Modeling <--> 2D Preparation.....	237
16.3	Creating and editing views.....	237
16.4	Limitations of AutoCAD in working with viewports.....	253
17.	SAVE TO METAL STUDIO 1 FORMAT.....	254
17.1	Save to Metal Studio 1 format	254

1. INTRODUCTION

1.1 Needed computer configuration

Since the '**Metal Studio**' program runs under the '**AutoCAD**' platform, in order to start the program running, it is required that both the operative system 'Windows' and the 'AutoCAD' program (version '2010' or later) are properly installed on your computer. As for the minimum computer configuration, it has been defined by the requirements of the operative system 'Windows' and the 'AutoCAD' program, so if these applications can run on your computer, then the '**Metal Studio**' will definitely run correctly.

1.2 Program installation

For the correct installation of the program, it is necessary to have a suitable hardlock and to download the appropriate installation archive from our website. Since there are both individual and network versions of our programs as well as various types of hardlocks (individual, network and time-restricted) you also need to know the serial number of the installation.

Every user has a unique serial number of the installation, which determines both the type of installation and the program operational mode. In case that at a later point you buy an additional module of the program you will get a new serial number as the previous one will no longer be valid.

You can install the program only if you own the right to install the program which means you must have the right to access the 'Administrator' system. Unlike the installation, there are no restrictions on the use of the program.

Prior to the '**Metal Studio**' program installation, it is necessary that the 'AutoCAD' program is started at least once otherwise the installation will not be executed.

Before starting the installation of the program, set the USB hardlock on the computer.

1.2.1 Individual program installation

All files required for the installation of the 'Metal Studio' program are packed in a self-extracting archive '**MetalStudio_***_x64_Setup.exe**', which is temporarily unzipped to the computer's memory during installation. You can download this archive from our website and then run it from your computer's hard drive. In doing so, make sure that the archive corresponds to the version of AutoCAD for which you are installing. After starting the installation, a dialog box with the following appearance will open:

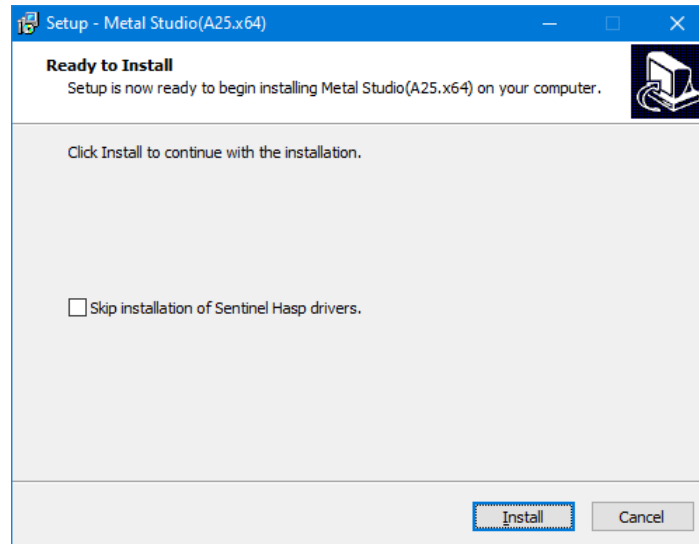

Skip installation of Sentinel Hasp drivers.

If the program is not installed for the first time, but only a new version (Build) is installed, by setting this check box to the on state, the installation of the Sentinel Hasp driver can be skipped, which will speed up the entire program installation procedure.

Now select the **'Install'** button, after which all the necessary files are unpacked into the computer's memory and the installation of the program itself begins. After installing the driver, the program will issue the following message:

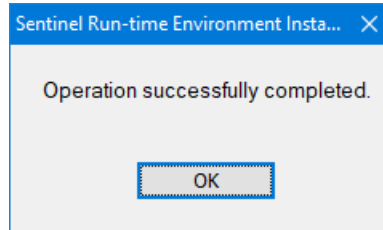

Activate the command field **'OK'**, after which the installation of the program will begin. The following dialog box will appear on the screen:

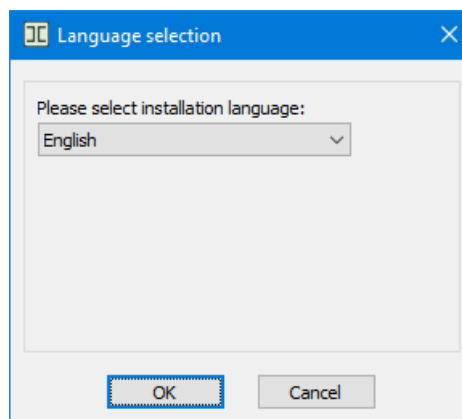

From the combo box, select the language of installation and then activate the **'OK'** command field.

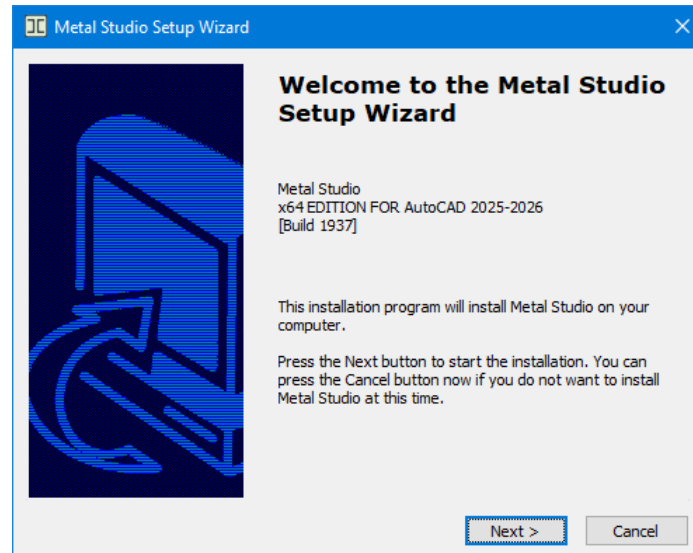

In order to proceed with the program installation, activate the **'Next'** command field.

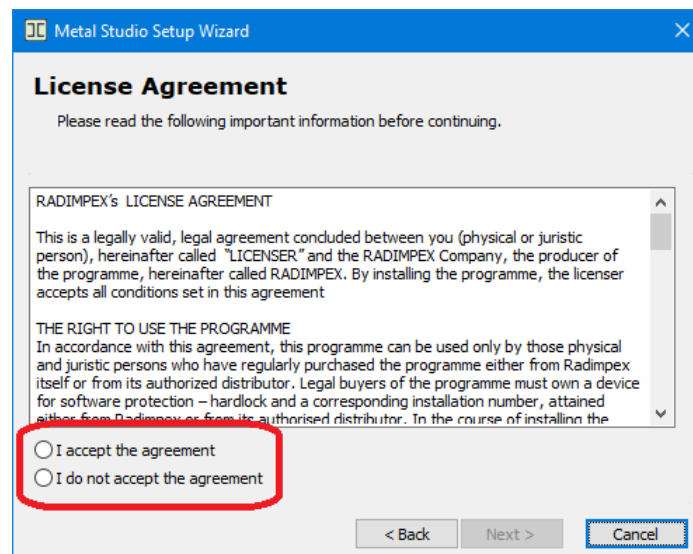

The central part of the displayed dialog box contains a license agreement which sets out the conditions of the program usage. We recommend that you study it carefully and only if you agree to these conditions, you can turn on the switch **'I accept the agreement'**. Soon after this, the **'Next'** command field will be available, upon activating which the procedure of program installation will proceed.

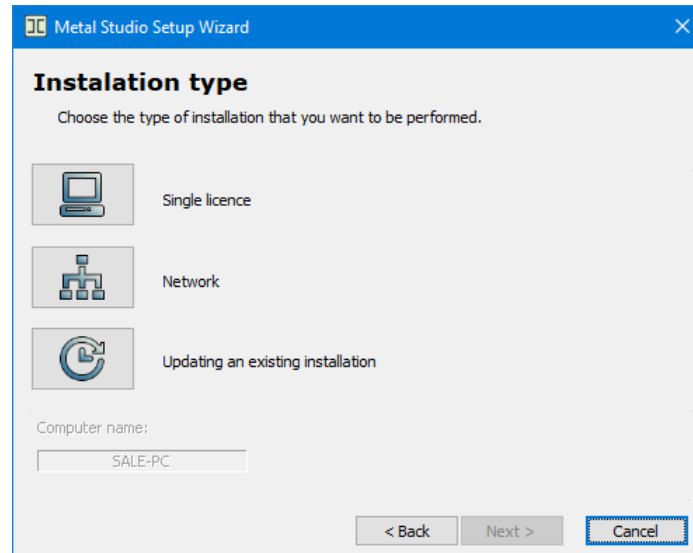

In this dialog box, you must specify whether an individual or a network program installation is about to start. For users who install a new version (Build) of the program, a quick installation option has been introduced.



By clicking the mouse on the '**Updating an existing installation**' icon, a quick installation of the program will be performed, via an already existing local or client installation, without entering the installation number and choosing a directory, while retaining all existing parameters and settings and without changing the license.

By clicking on the '**Single licence**' icon, you can set this type of installation as the current one, and then you must activate the '**Next**' command field.

In case that the 'AutoCAD' program has not been installed on your computer, first a suitable warning message will appear and then the procedure of the '**Metal Studio**' program installation will be aborted.

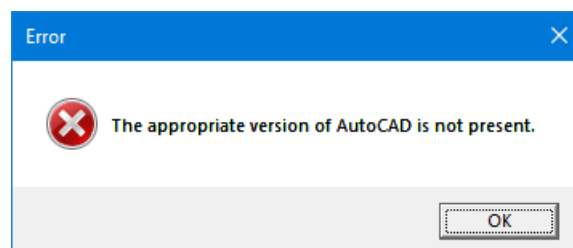

In case that more than one version of the 'AutoCAD' program has been installed on your computer, the following dialog box will appear on the screen:

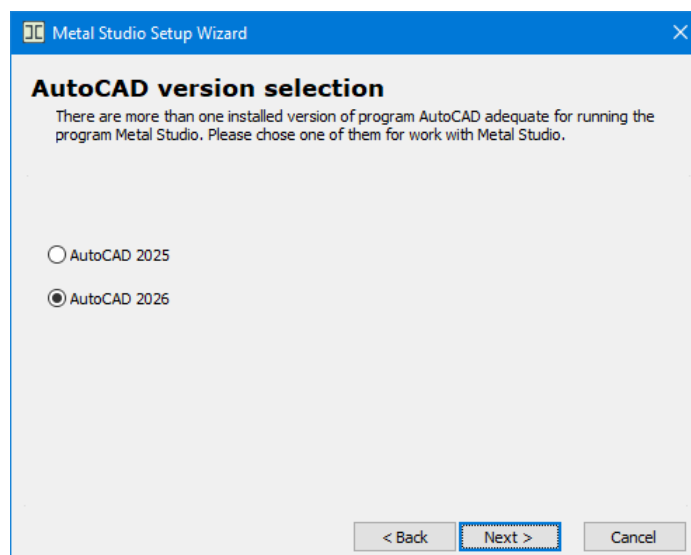

In the displayed dialog box, select the program version you want to install. Please note that, by activating the '**Back**' command field, in any dialog box, you can go back to the previous step of the installation, whereas by activating the '**Cancel**' command field you can quit the entire procedure of program installation. In order to proceed with the program installation, turn on the appropriate switch, select the desired version of the 'AutoCAD' program and then activate the '**Next**' command field.

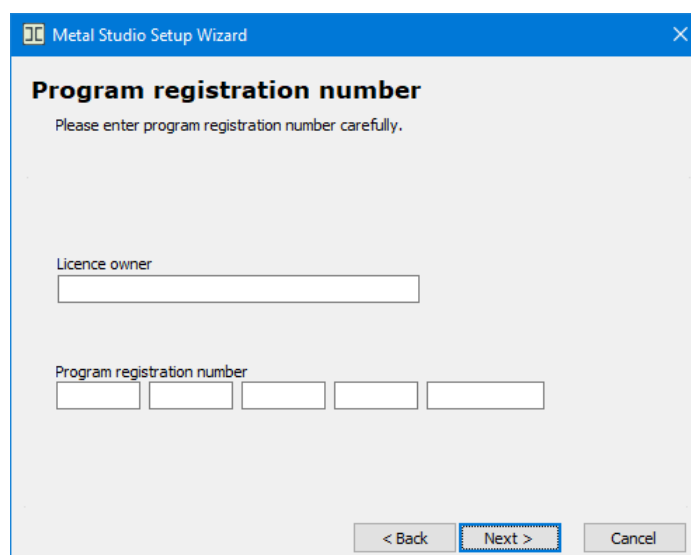

In the '**License owner**' edit box, key in the correct name of your company since these data will be displayed at the bottom of every page of your project. Please note that once you have agreed to the conditions of the agreement, you are obliged to write the correct name of the license user.

In the '**Program registration number**' edit box, assign carefully the correct serial number of the installation which you have received from your distributor and then activate the '**Next**' command field.

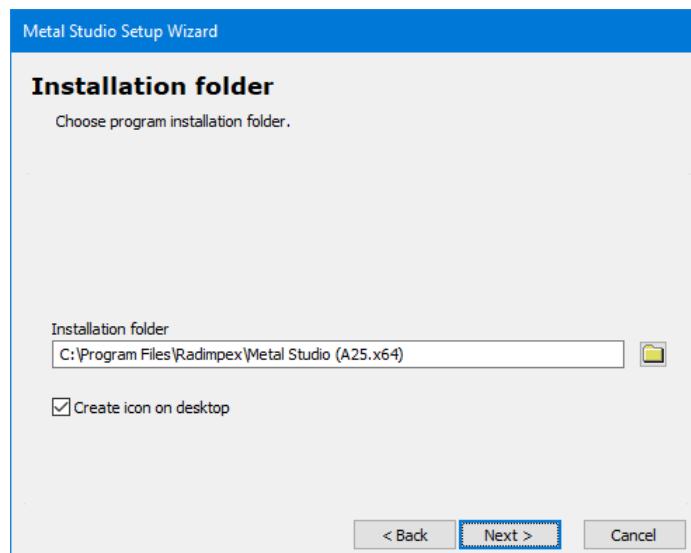

In the displayed dialog box, assign the place on the hard disk where you want to install the program. If the proposed path does not meet with your requirements, you can either assign a completely arbitrary place on the disk in the '**Installation folder**' edit box or select the desired path by clicking on the '📁' command field which is on the right of this edit box.

Create icon on desktop - if this check box is on, the program will create an icon on the computer's desktop that can be used to run it.

Once you have assigned the place on the disk, activate the '**Next**' command field in order to proceed with the program installation.

In case that, in the assigned installation directory, this program has already been installed, a dialog box will appear, which will enable you either to keep the existing configuration databases or replace them with new ones.

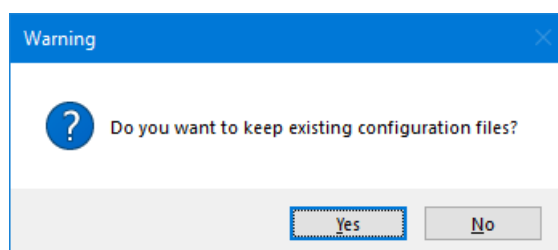

In order to enable you to choose more easily one of the actions designed by the program, we shall give you a list of databases which store data available for change during running the program:

MetalStudio2.\$bks	Database of layout configurations
MetalStudio2.\$bp	Database of regulations
MetalStudio2.\$bpk	Database of labeling parameters
MetalStudio2.\$brcl	Database of plate workshop drawing
MetalStudio2.\$brcs	Database of girder workshop drawing
MetalStudio2.\$btpk	Database of arbitrary label texts

MetalStudio2.\$cws	Database of user-defined names of weld symbols
MetalStudio2.\$dzv	Database of bolt lengths
MetalStudio2.\$eds	Configuration database created by the command 'Parameters'
MetalStudio2.\$har	Database of standard papers used when creating reports (specifications, summaries)
MetalStudio2.\$mk	Database of structure materials
MetalStudio2.\$mss	Database of bolt materials
MetalStudio2.\$mtz	Database of user-defined sections
MetalStudio2.\$omi	Database of most frequently used sections
MetalStudio2.\$op	Database of bolt accessories
MetalStudio2.\$pbp	Profile color configuration database set using the 'Profile color setting' command'
MetalStudio2.\$prf	Database of shapes
MetalStudio2_GOST.\$prf	Database of GOST hot rolled shapes I, L,C
MetalStudio2_UPE.\$prf	Base of UPE hot-rolled profiles
MetalStudio2.\$pv	Database of weld parameters
MetalStudio2.\$pvk	Database of elevation label parameters
MetalStudio2.\$pz	Database of bolt label parameters
MetalStudio2.\$rbk	Data on Toolbar
MetalStudio2.\$skl	Labeling style of plates
MetalStudio2.\$sklp	Labeling style of plate plan view
MetalStudio2.\$skprs	Labeling style of arbitrary girder represent
MetalStudio2.\$skrcl	Labeling style of plate workshop drawing
MetalStudio2.\$skrcs	Labeling style of girder workshop drawing
MetalStudio2.\$sks	Labeling style of girder
MetalStudio2.\$sksl	Labeling style of bended plate
MetalStudio2.\$sksp	Labeling style of girder plan view
MetalStudio2.\$ssp	Labeling style of section symbol
MetalStudio2.\$szc	Database of bolt series parameters

MetalStudio2.\$vl2	Configuration database for the complex element Lateral connection of I–shape beams
MetalStudio2.\$vl3	Configuration database for the complex element Column base
MetalStudio2.\$vl4	Configuration database for the complex element Beam to beam splice
MetalStudio2.\$vl5	Configuration database for the complex element Column beam connection
MetalStudio2.\$zav	Database of bolt parameters

These files are saved in the directory 'C:\Users\Username\AppData\Roaming\ Radimpex\Metal Studio'.

If, during running the program earlier, you have already customized all databases to meet your individual needs, we recommend that you now activate the '**Yes**' command field which will lead to installing only executive programs whereas the configuration databases will remain unchanged.

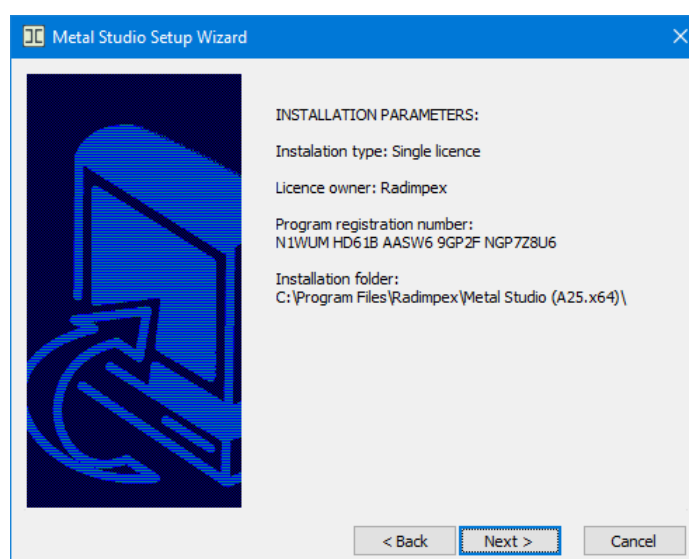

The program now displays all the parameters you have set during the installation, and if they meet with your requirements, you can activate the '**Next**' command field, upon which the procedure of the program installation will start. Soon the information about the successful execution of the installation will be displayed on the screen.

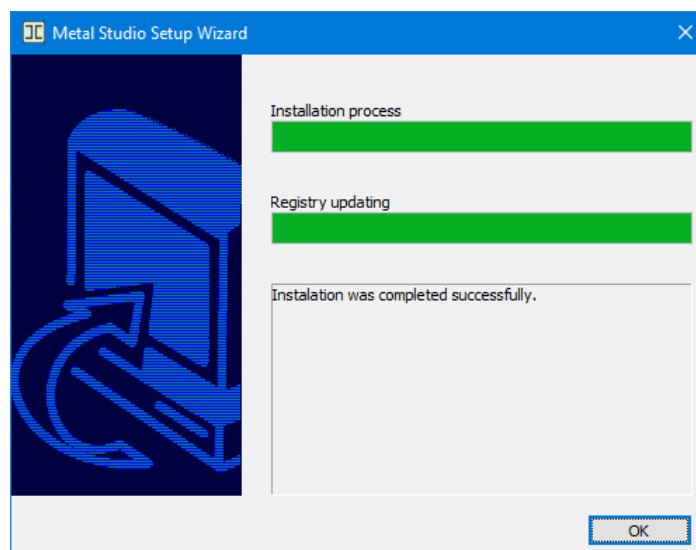

Upon activating the **'OK'** command field, the program installation will end.

In case that a hardlock has not been connected to your computer, the program will abort the procedure of installation and issue an appropriate warning.

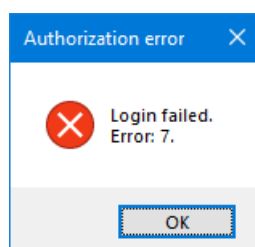

On the other hand, if a hardlock has been connected to your computer but you have made a mistake during assigning the registration number, the **'Next'** command field will be unavailable for activation. The program will notify you in the dialog box that the incorrect registration number has been assigned.

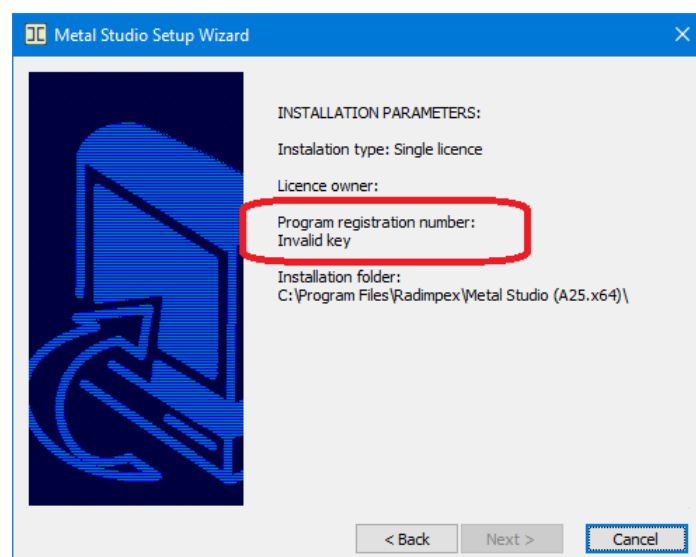

In this case, the only thing you can do is, by activating the **'Back'** command field, to go back to the dialog box for assigning the registration number, and reassign it correctly.

1.2.2 Network installation

In order to enable the program to run on all computers in the network, it is necessary that at least one of the following protocols TCP/IP, NETBIOS or IPX has been established among them. The procedure of network installation is performed in two steps. In the first step, the server installation is performed onto the server disk. In the second step, from the server disk, the client installation is performed on all terminals which require the program running. Apart from this, 'HASP License Manager' program, which controls the operation of the network hardlock, must be active all the time.

Since the server is used only to enable the hardlock connection and for placing execution programs, its performance does not affect the speed of running the program. It is much more important that the network itself is fast enough so that checking the hardlock presence is done as fast as possible.

Server installation

Since the server's performance does not affect the speed of running the program, it follows that any computer in the network can be declared as a server. Therefore, it is important that you execute the server program installation onto it, connect the network hardlock and make sure the 'HASP License Manager' is active. Since, during the installation, the program writes a lot of data required for running the execution program in the 'Registry', you must log in onto the server as 'Administrator'.

You can download the installation file '**MetalStudio_***_x64_Setup.exe**' from our website and then run it from your computer's hard drive. In doing so, make sure that the archive corresponds to the version of AutoCAD for which you are installing. After starting the installation, carry out exactly the same procedure as for the individual installation (see chapter '1.2.1'). Of course, in this case, it is necessary to select the '**Network**' icon for the type of installation.

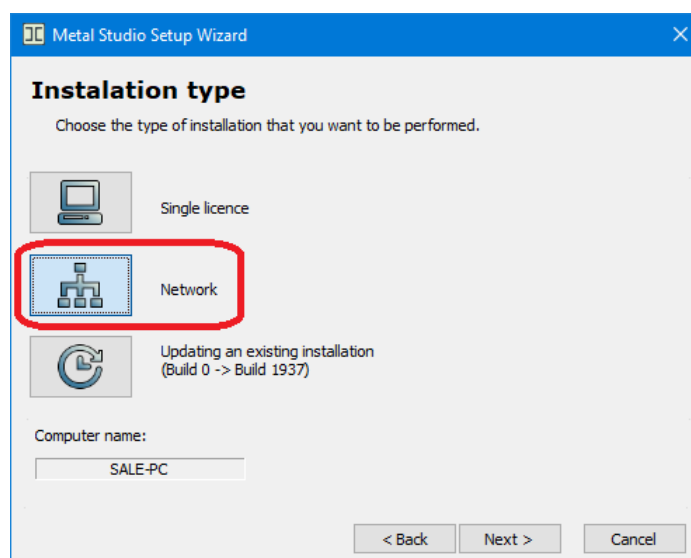

After the server installation is completed, the directory in which it was installed is located on the server. If you did not change the path provided by the installer, this directory is located on the server's C:\ drive and is called '**Metal Studio (***.x64) Server**'. All files necessary for the client installation of the program are located in this directory, packaged in a single self-extracting archive with the name '**Metal Studio_***_x64_ClientSetup.exe**'.

Besides this archive, the server installation directory also contains the file '**NETHASP.ini**' which is automatically generated during the network installation. This file contains configuration parameters for the establishment of communication with a hardlock. Users with standard network should not have any reason to modify this file. The presence of this file allows certain atypical client installations.

The most important part of NETHASP.INI file is the line that begins with:

NH_SERVER_ADDR =

The content of this variable defines the name or IP address of the computer with attached network hardlock. This field is automatically filled with the name of the computer on which the network installation is performed. If for any reason you need to change this information in order to perform the client installation, you can do it with any text editor (for example - notepad.exe).

If you want to enter server name, the syntax is:

NH_SERVER_ADDR = server_name;
(for example: NH_SERVER_ADDR = SERVER01;)

If you want to enter server IP address, the syntax is:

NH_SERVER_ADDR = xxx.xxx.xxx.xxx;
(for example: NH_SERVER_ADDR = 192.168.0.56;)

'HASP License Manager' installation

After the server installation is complete, it is necessary to install the '**HASP License Manager**' program on the server. You can download this program from our website, and then run the file '**\\HASP_LM_setup\lmsetup.exe**' from your computer's disk.

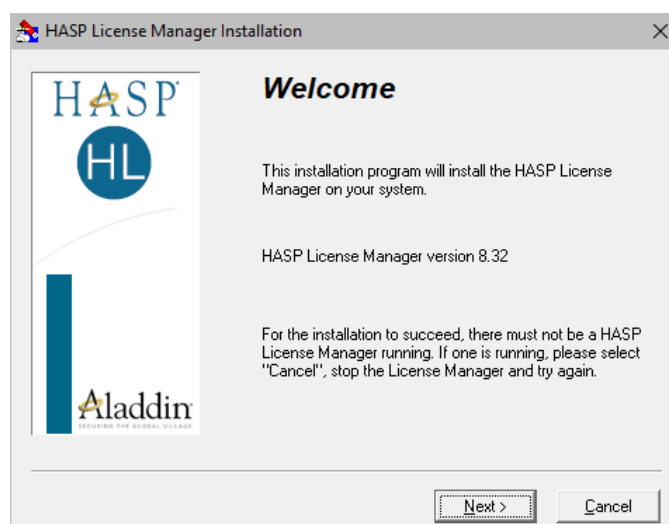

Upon activating the '**Next**' command field, the following dialog box appears on the screen:

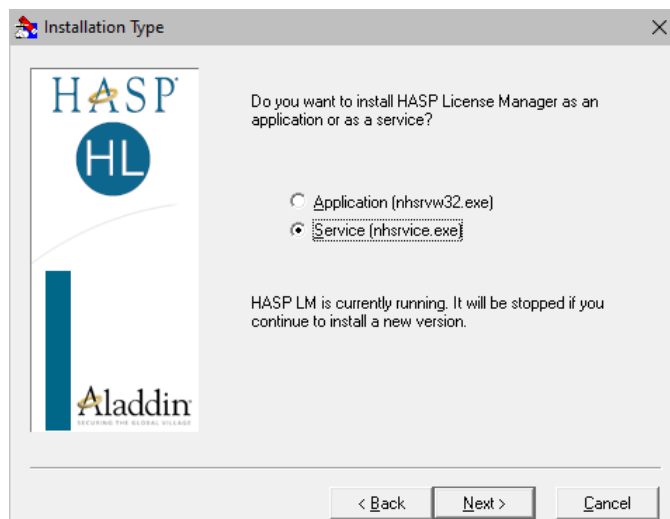

Two modes of installation are offered. Choose an option '**Service (nhsrvce.exe)**', which installs 'HASP License Manager' as a 'Windows' service. This mode of installation enables 'HASP License Manager' automatic startup every time you restart the computer and prior to the 'Log-in' procedure.

After activating the command field '**Next**', a dialog box will be displayed in which you may customize (or accept the proposed) 'HASP License Manager' installation folder.

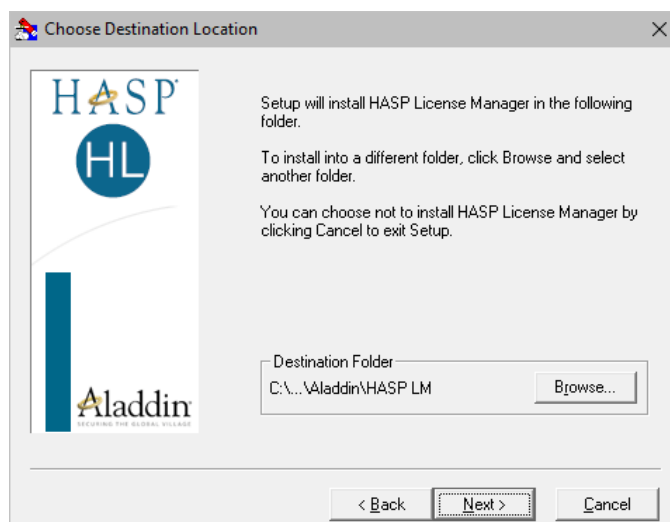

By activating the '**Next**' command field in this, but also in several other dialog boxes, 'HASP License Manager' installation will be brought to an end.

Client installation

From the computer on which you want to run the program, you must position yourself onto the server disk and start the '**MetalStudio_***_x64_ClientSetup.exe**' installation program from the directory where the server installation has previously been performed. If you have not changed the default path proposed by the installation program during the server installation, then it is located on the server disk in the '**C:\Metal Studio Server**' directory.

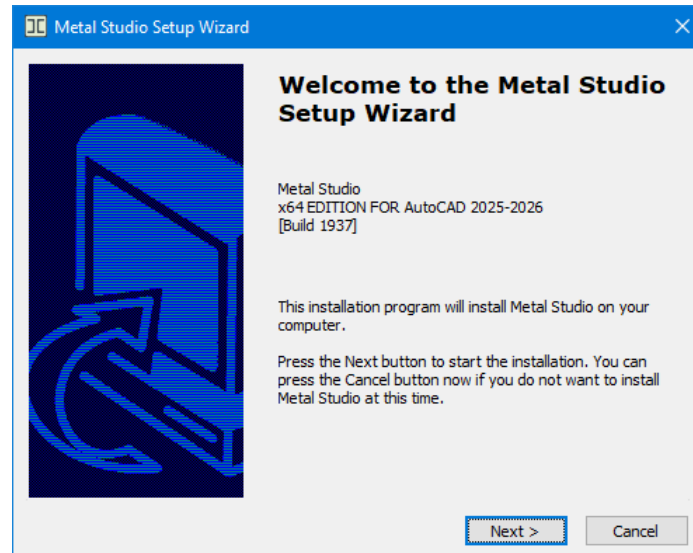

To proceed with the client installation, activate the **'Next'** command field.

In case that the 'AutoCAD' program has not been installed on your computer, an appropriate warning message will appear on the screen upon which the procedure of the **'Metal Studio'** program installation will be aborted.

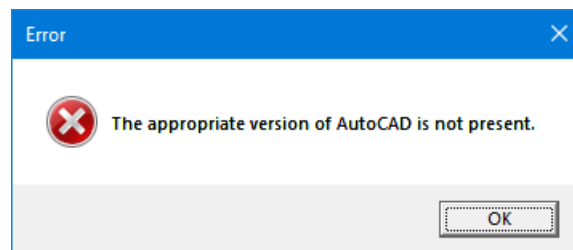

In case that more than one version of the 'AutoCAD' program has been installed on your computer, the following dialog box will appear on the screen:

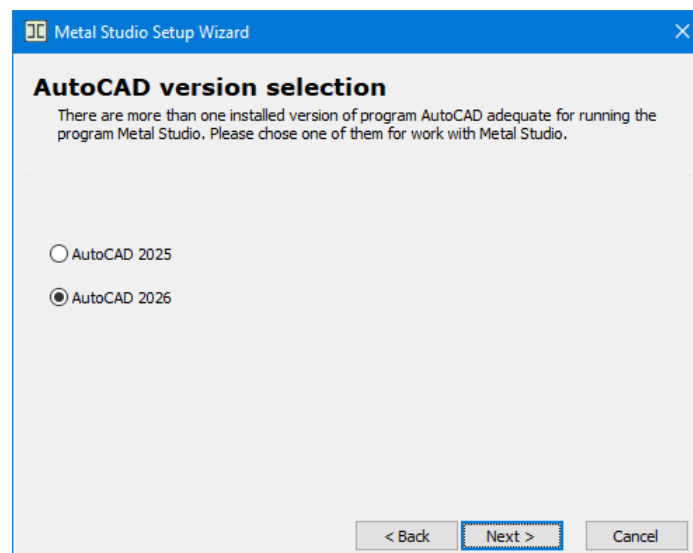

Here, also, same as in case of individual program installation, you must choose a program version you want to install. Once you have chosen the desired version, activate the **'Next'** command field.

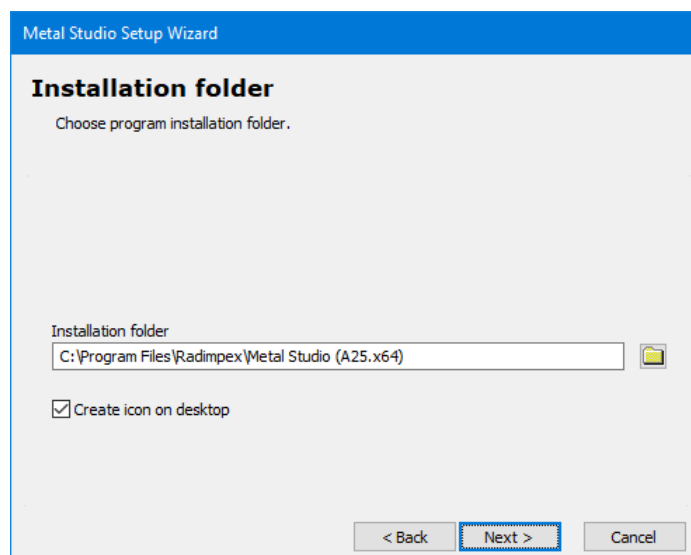

In this dialog box, assign the place on the disk where the client installation will be installed and then activate the '**Next**' command field.

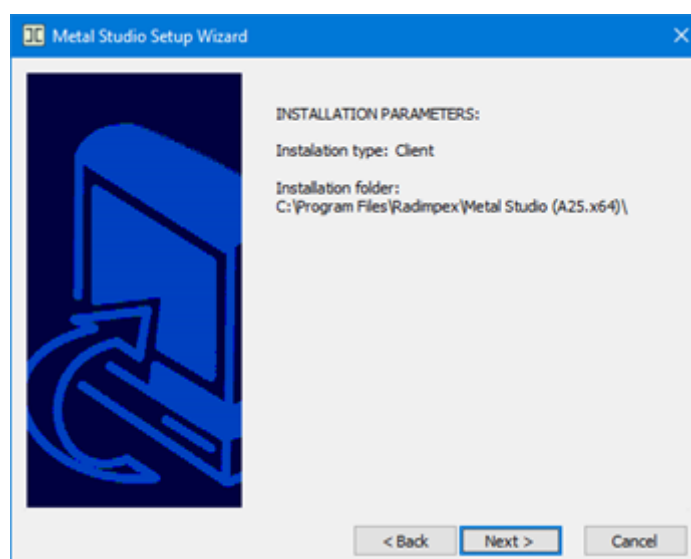

The program now displays all the parameters you have set during the client installation, and if they meet your requirements, you can activate the '**Next**' command field, upon which the procedure of the program installation will start. Soon the information about the successful execution of the client installation will be displayed on the screen.

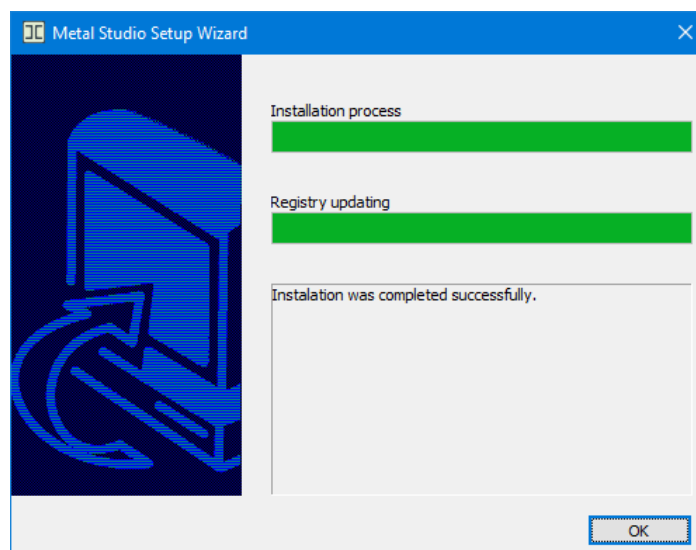

The previously described procedure of the client installation can also be performed on all the other computers in the network on which you want to use the program.

1.3 Starting the program

Since, during its operation the program constantly verifies whether a hardlock is present, you must connect it to a USB port of your computer prior to starting the program. The program is started by activating the '**Programs ► Radimpex ► Metal Studio**' option from the '**Start**' menu. In the case of the client installation, you must select the '**Programs ► Radimpex ► Metal Studio Client**' option.

In both cases, first the splash screen will be displayed on the screen, and then it will be followed by the '**Metal Studio**' program.

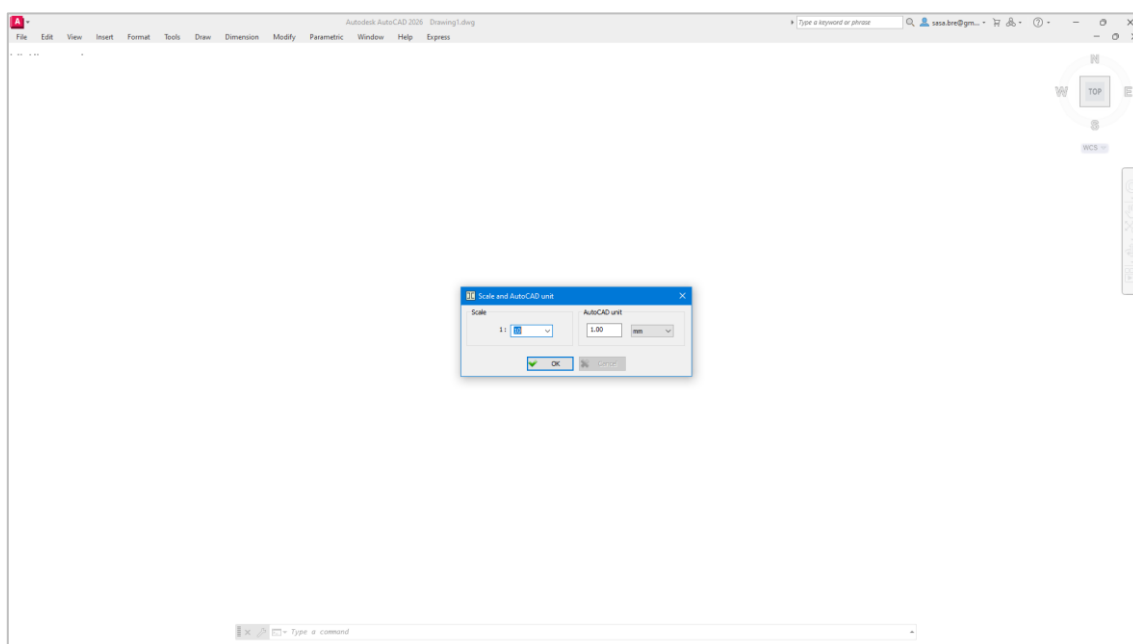

Now you must assign the main drawing scale in the way it was described in the chapter 'Setting the drawing scale'.

When first starting the program, Toolbars with icons of all **'Metal Studio'** commands are set on the drawing surface of the 'AutoCAD' and they should be arranged along the outside borderlines – by dragging the mouse. Additional operations with Toolbars (switching on and off, creating new ones or modifying the existing ones) are performed via the 'AutoCAD' command **'Tools ► Customize ► Toolbars...'** the operation of which has been explained in the instruction manual of the 'AutoCAD' program.

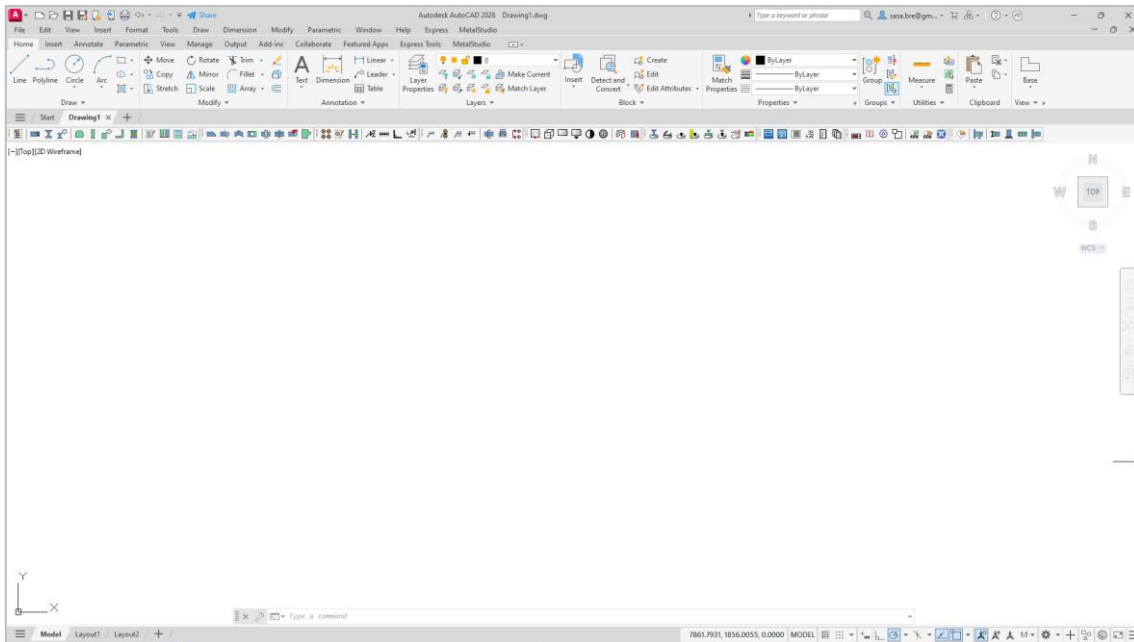

1.4 The basic concept of the program

The 'Metal Studio' program was written in the 'C++' program language and using the 'ObjectARX' library connected to the 'AutoCAD', which means that it cannot operate independently, but only within the 'AutoCAD' program package.

The 'Metal Studio' commands are contained within the drop-down menu 'Metal Studio' and the in Toolbar and they can be called equally from both locations.

In course of its operation, the 'Metal Studio' program creates a large number of different types, interdependent and related objects and entities (entities represent objects which are drawn). These objects and entities contain all necessary numerical and geometric data which can be edited and changed.

At every moment of working with the program, it is possible to generate the specification, summary and workshop drawings of girders and plates.

The objects and entities hierarchy in the 'Metal Studio' program is as follows:

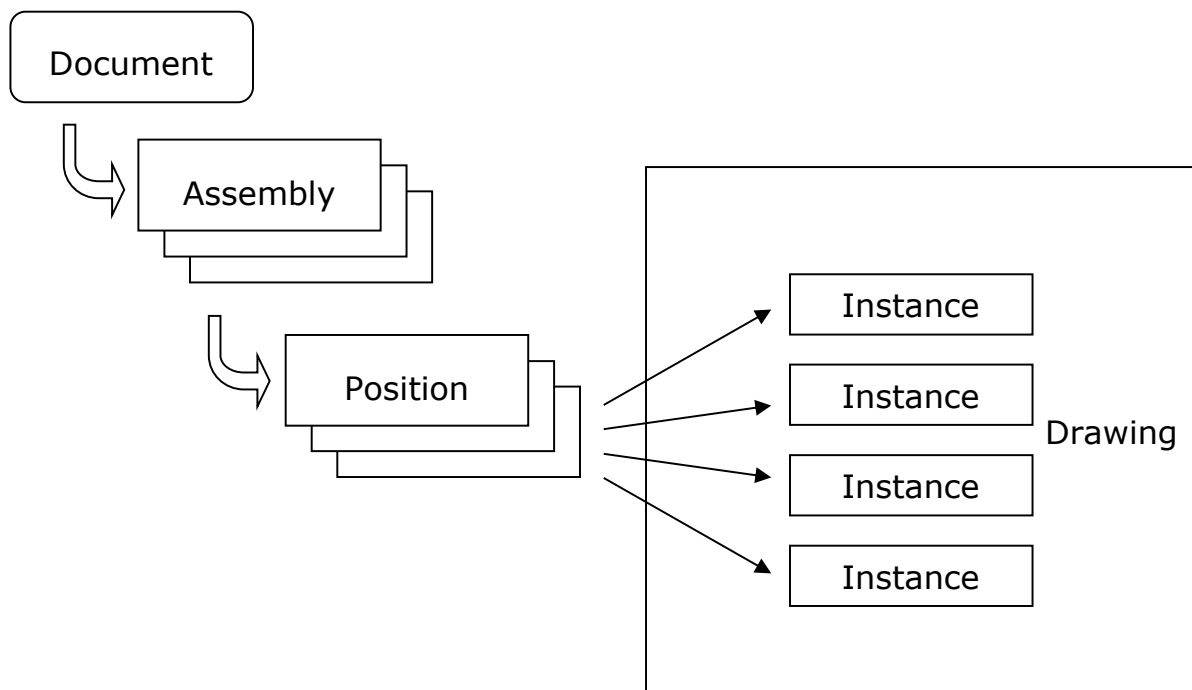

At the top, there is the main object, the 'Document', the owner of all other objects and entities. A single drawing contains only one 'Document'.

Located hierarchically immediately below the document, there is an object 'Assembly', which relates to a particular physical entity of the structure. A single document may contain several assemblies.

Located hierarchically immediately below the 'Assembly', there is an object 'Position', which relates to data on structural element. Data such as shape and material relate to girders and plates. Positions which relate to girders are called 'Girder positions' whereas positions which relate to plates are called 'Plate positions'. A single assembly may contain several positions (up to 1000).

An entity is an object with a graphic presentation (it is drawn), and the most important entity is 'Instance'.

An instance represents a graphic presentation of a particular girder position or a plate position. A single position may contain several instances, in other words, it can appear in several places in the drawing and also in several different views.

There are two types of instances - material and immaterial:

- Material instances are 'Girder' and 'Plate', and they are the shapes carrier in the spatial geometry. They can be referred to as 'physically tangible'.
- Immaterial instances are 'Girder plan view' and 'Plate plan view'. They represent a 2D picture obtained on the basis of a certain material instance we have seen in a certain view. From a single material instance, it is possible to create an arbitrary number of immaterial instances, by selecting different views of the material instance.

Whenever a material instance which is presented in a certain view is changed, the picture in that view also changes. Both material and immaterial instances can be labeled, edited and changed.

Due to the fact that immaterial instances are simply 2D pictures, it is not possible to obtain from immaterial instances other immaterial instances.

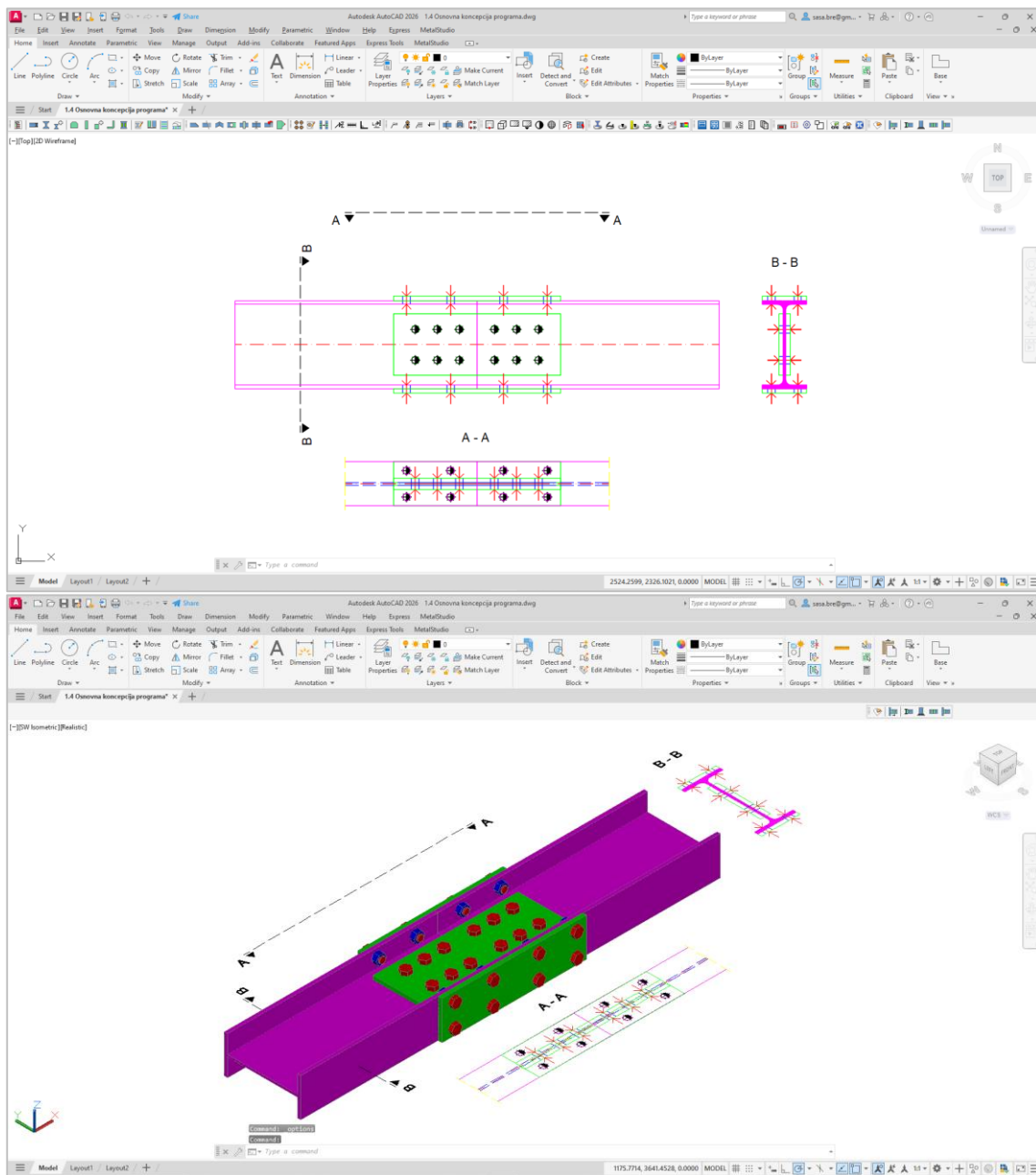

The figure above shows a 2D drawing, whereas the figure below shows a 3D model of the entity from the figure above, so it can be quite clearly seen which instances are material and which are not.

Other types of instances are references, bolts and auxiliary entities.

- References are entities which are used for marking instances and displaying data on these instances. These are not independent entities because their life cycle is dependent upon the existence of the instance to which they are related i.e. for which they have been created. In the 'Metal Studio' program, references are 'Labels' and 'Weld labels'.

- Bolts are entities which are used for viewing bolts. Same as references, bolts are not independent entities and their life cycle is dependent upon the existence of the instance (a girder or a plate) which is the 'carrier' of an object called 'Bolt series'. Same as instances, bolts can be both material (real bolts) and immaterial (bolt plan view).
- Auxiliary entities are entities which are used for presenting various kinds of information - section symbols, height coordinates and other ways of marking.

Other important notes:

- Same as in the 'AutoCAD' program, all drawing is performed in the 'AutoCAD' drawing units and, within the 'Scale' command, it is defined what corresponds to one 'AutoCAD' drawing unit for each drawing separately. Normally, scale setting is performed during starting a new drawing.
- Almost all 'AutoCAD' commands for manipulating with drawing elements ('Erase', 'Copy', 'Mirror', 'Move', 'Rotate', ...) have the same effect on entities from the 'Metal Studio' program. In addition, these entities have built-in and specific grips, by stretching which you can easily affect their geometry. The program will certainly make sure that all changes made in the 'AutoCAD' graphic editor automatically apply to all other dependent elements of drawing, thus providing the constant update of the current state in the drawing.

Explode - if this AutoCAD command is applied over Metal Studio's material instances (Girders and Plates) in 3D View, AutoCAD entities 3D Solids will be obtained as a result. If this command is applied to Metal Studio's material and non-material instances in 2D View, the result will be AutoCAD lines.

1.5 3D Modeling

The Metal Studio program is a modern tool for creating highly professional drawings of metal structures. Enables the creation of quality project documentation including complete and detailed specification and recapitulation and workshop drawings. The Metal Studio program has successfully combined great ease, simplicity, speed of work with great functionality.

During the first fifteen years of its existence, the Metal Studio program went through the process of actualization and addition of new minor or major functionalities several times. One of the great advantages of the program has always been the ease and simplicity of work, which came from predominantly 2D drawing with the addition of 3D modeling tools. That 2D - 3D hybrid way of drawing, in addition to its advantages, still had its limitations.

The development direction of the Metal Studio program is almost exclusively focused on enabling true 3D modeling while maintaining the ease that exists in 2D mode of operation.

The improvement brought by Metal Studio 2 is not only in switching the entire modeling to 3D and allowing the 'freedom' to draw everything in 3D mode. The most important novelty brought by Metal Studio 2 is the possibility to use the ease of 2D (planar) mode of operation in 3D modeling.

3D Modeling

As an example of 3D modeling with the ease of working in 2D views, we had our Tower program.

Of course, since Metal Studio is an AutoCAD application, we had to fit within AutoCAD's existing capabilities and limitations.

The principle of 3D modeling in Metal Studio 2 is based on two concepts - '2D view' and (multiple) 'viewports'.

The '2D view' represents a part of the spatial model of the construction being drawn. Its characteristics are plane, region and depth. A '2D view' can represent entities such as a frame, a level or an arbitrary inclined plane (slanted frame or inclined level).

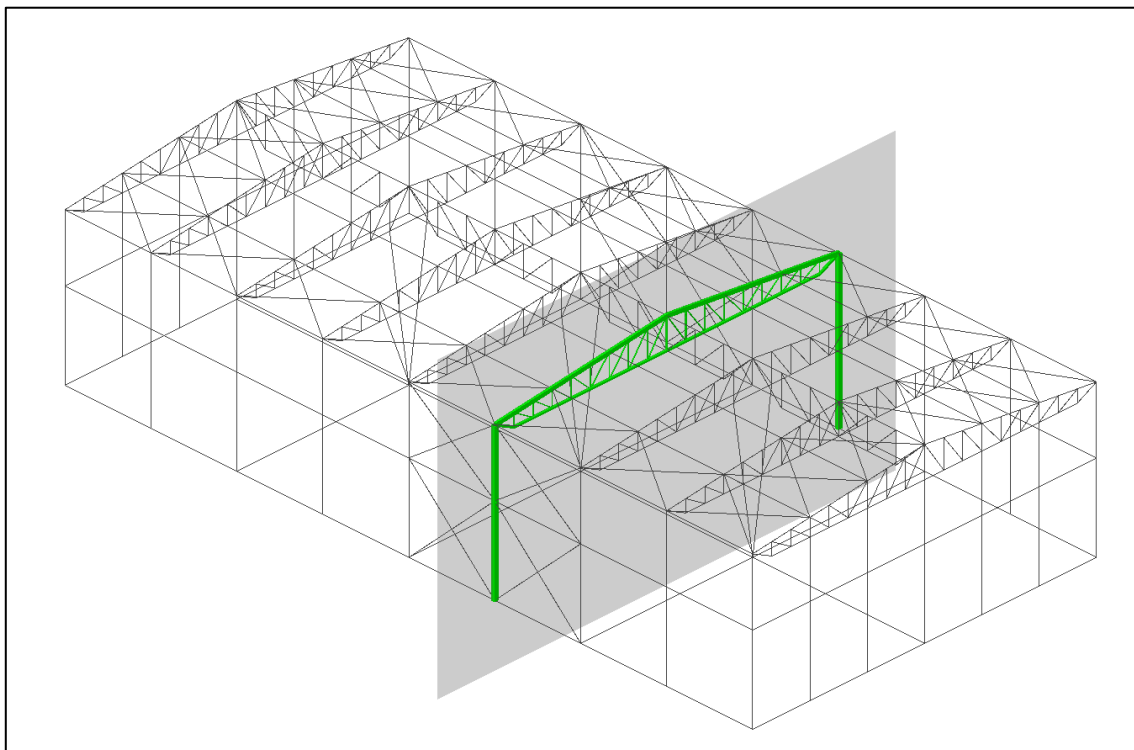

The view can be a single frame

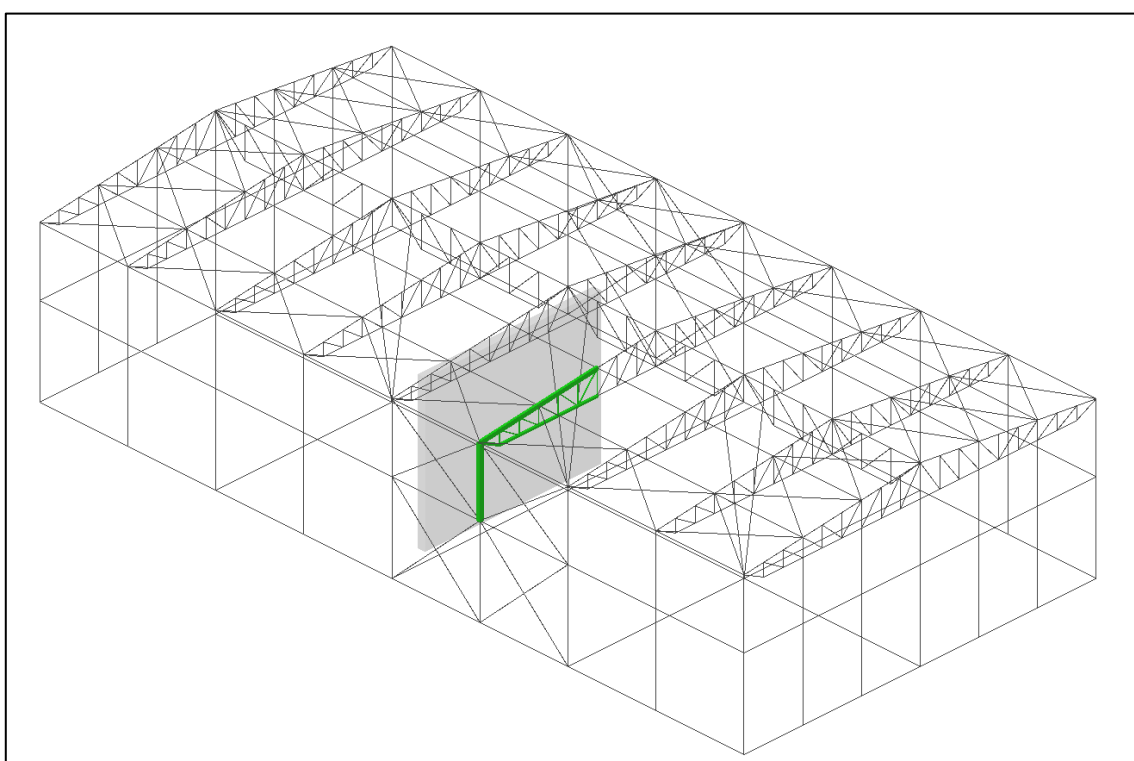

The view can be changed, so that only part of the frame can be displayed

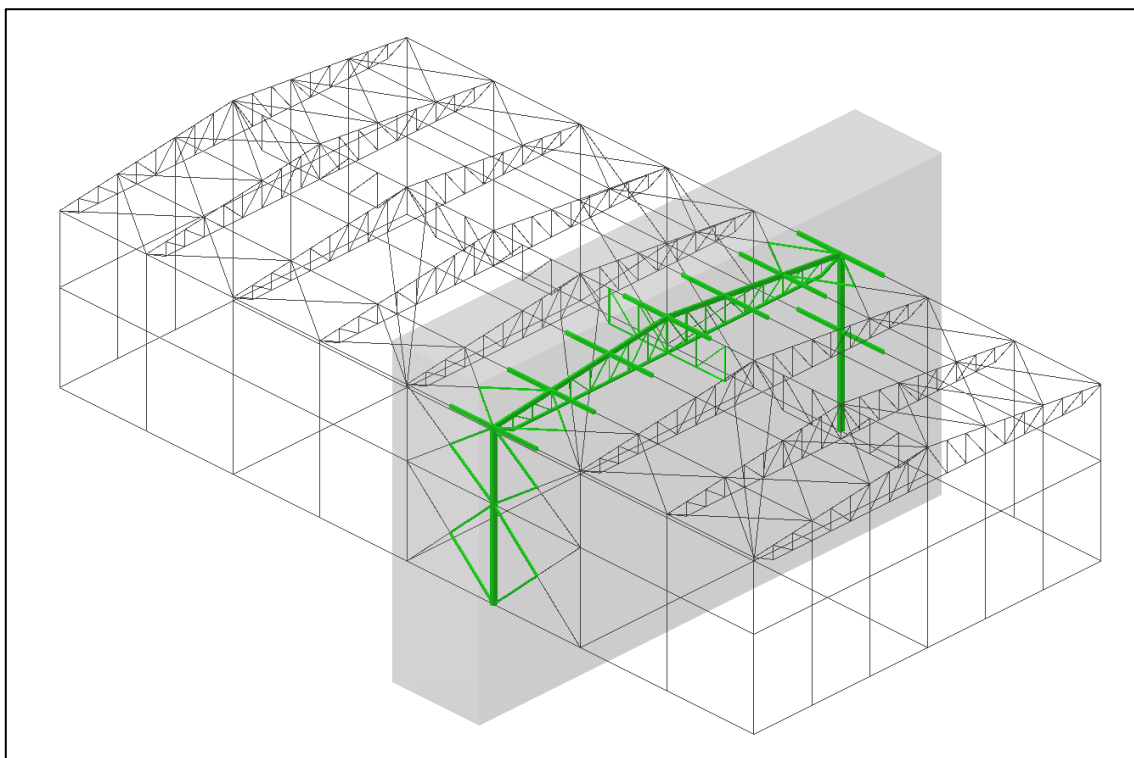

The view can also be given a 'depth', which means that the view plane practically becomes a cuboid, and everything in it is displayed

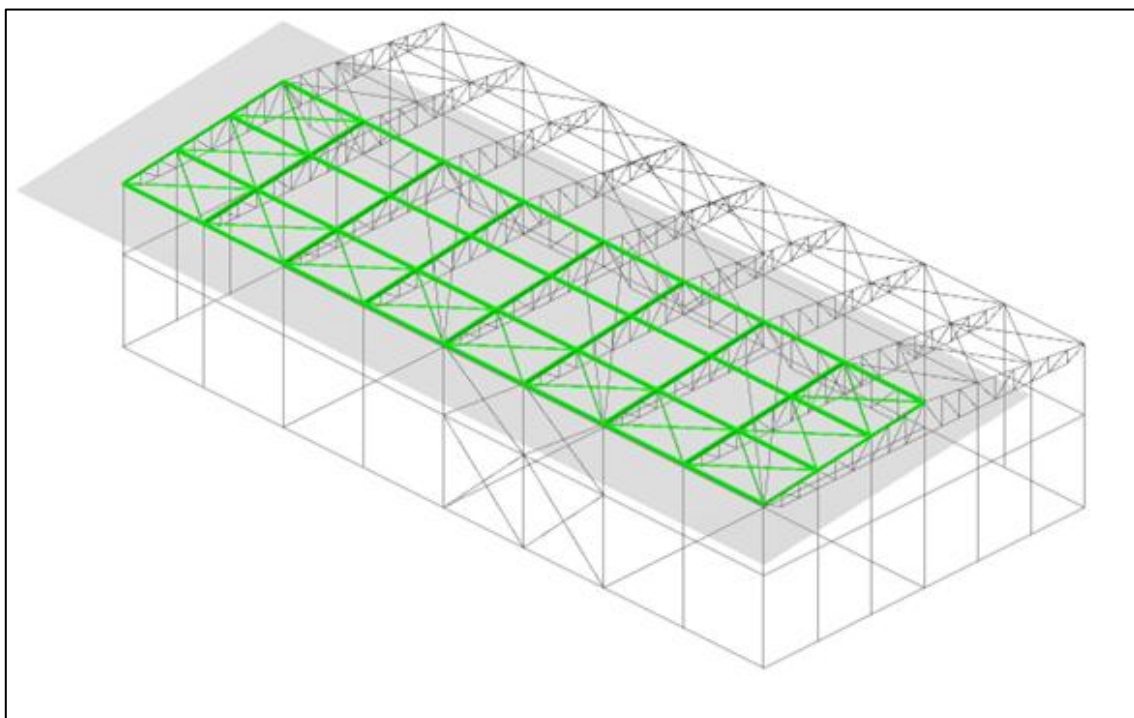

The view can be a completely arbitrary oblique plane

A Metal Studio 2 user can create any number of '2D views'.

The basic drawing mode in AutoCAD ('world draw') always shows the entire 3D model projected on the XOY plane. This means that its use cannot achieve what is desired - neither an arbitrary transformation in an arbitrary coordinate system nor an isolated representation of a part of the model.

For this reason, an alternative drawing system in AutoCAD that is implemented using 'viewports' must be used.

'Viewports' in AutoCAD defines the parameters we need - plane, range and depth. For an AutoCAD user, it is almost impossible to distinguish whether the plotting is done using the viewport or the general mode.

What you get by using viewport is that in one viewport you can display the selected '2D view' and in that viewport you can draw and use the graphic editor as if it were a normal plane drawing. At the same time, everything that is done is done in a unique 3D model.

AutoCAD supports the simultaneous use of multiple viewports, each of which can display a different 2D view.

A single viewport besides being able to display any user-defined 2D view, can also display two special views - the first is the 'Canonical XOY' view and the second is the '3D view'.

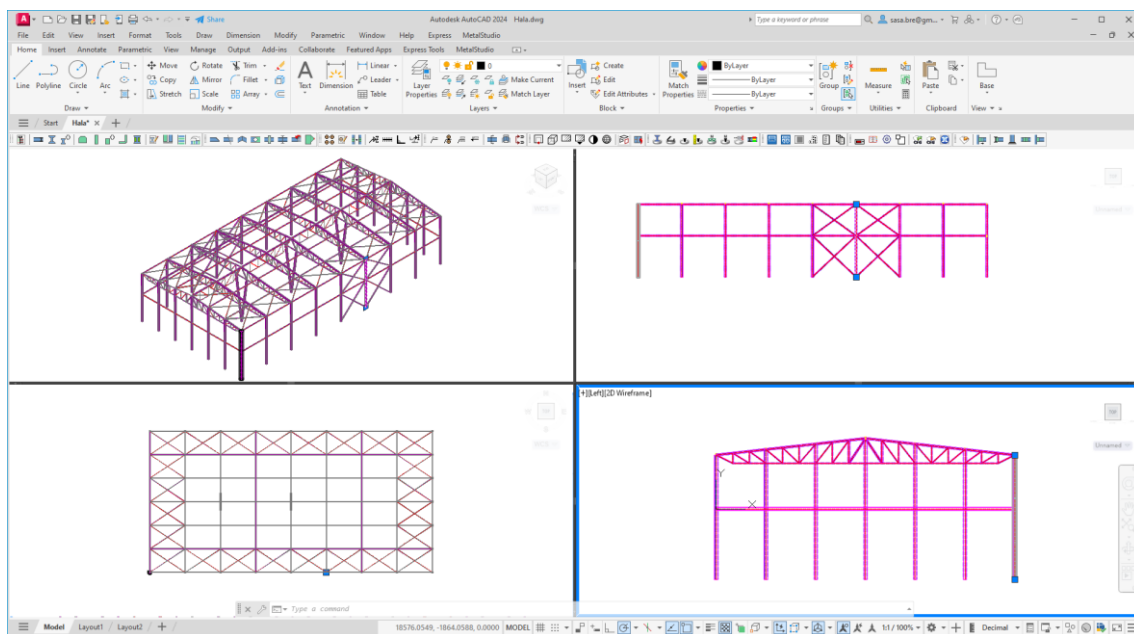

The picture shows four viewports. The top left viewport shows the 3D view, the bottom left shows 'Canonical XOY', while the top and bottom right viewports show one horizontal and one vertical frame.

The canonical XOY viewport shows everything that contains the current drawing projected onto the XOY plane. The '3D view' shows everything that contains the current drawing, but drawn in space.

Two operating modes

Although we previously wrote that it is practically impossible for the user to distinguish whether drawing in AutoCAD is done through the viewport system or the general way, there are still certain differences in their use and capabilities.

On the technical side, there are some minor flaws and imperfections in AutoCAD when it comes to using viewports versus standard plotting. These defects do not affect the essence and the possibilities of work and 3D modeling, but they can come to the fore during the preparation of drawings for printing. For this reason, there are two modes of operation of the Metal Studio program, which differ in whether viewports or standard drawing mode ('world draw') are used for drawing.

Plotting using the viewport is necessary for the 3D modeling process, and the standard plotting method has advantages in the preparation of drawings for printing and the printing process itself.

AutoCAD can use only one drawing system at a time, and in Metal Studio 2 it is possible to easily switch from one to another.

It is recommended that the entire modeling work be done in the '3D modeling' mode that works with viewports, and that the '2D Preparation' mode be used when preparing drawings for printing.

1.6 Symbols used in the program

During the 'Metal Studio' program installation, all databases with symbols used by the program are copied on the local hard disk.

- | | |
|--------------------|--|
| SymDim.dwg | Database with shape symbols which can be displayed in a label. |
| SymBolt.dwg | Database with bolt symbols. |
| SymWeld.dwg | Database with symbols which can be displayed in a weld label (weld marks symbols, field weld symbols, etc.). |

The files are saved in the directory 'C:\Users\Username\AppData\Roaming\Radimpex\Metal Studio'.

These databases can be modified, i.e. symbols which are stored in them can be added, deleted and edited. Creating a symbol is very simple: first it is drawn using the 'AutoCAD' commands and then it is turned into a 'Block' via the 'AutoCAD' command 'Make Block'. It is important that the block name is a descriptive one because the symbol is called via it in the program. Since symbols are basically common blocks, it is necessary that you use suitable 'AutoCAD' commands if you want to change them.

In order to enable placing these symbols correctly on a drawing at a later point, it is necessary to comply with certain rules during creating them. The symbol bounding box in the 'SymDim.dwg' database should not be greater than 20x20 AutoCAD units (ACU), whereas when creating a block the center of the bounding box should be chosen for the reference point. In symbols which are delivered with the program, the bounding box is displayed as a square in grey color, whereas the reference point is marked with a small red cross.

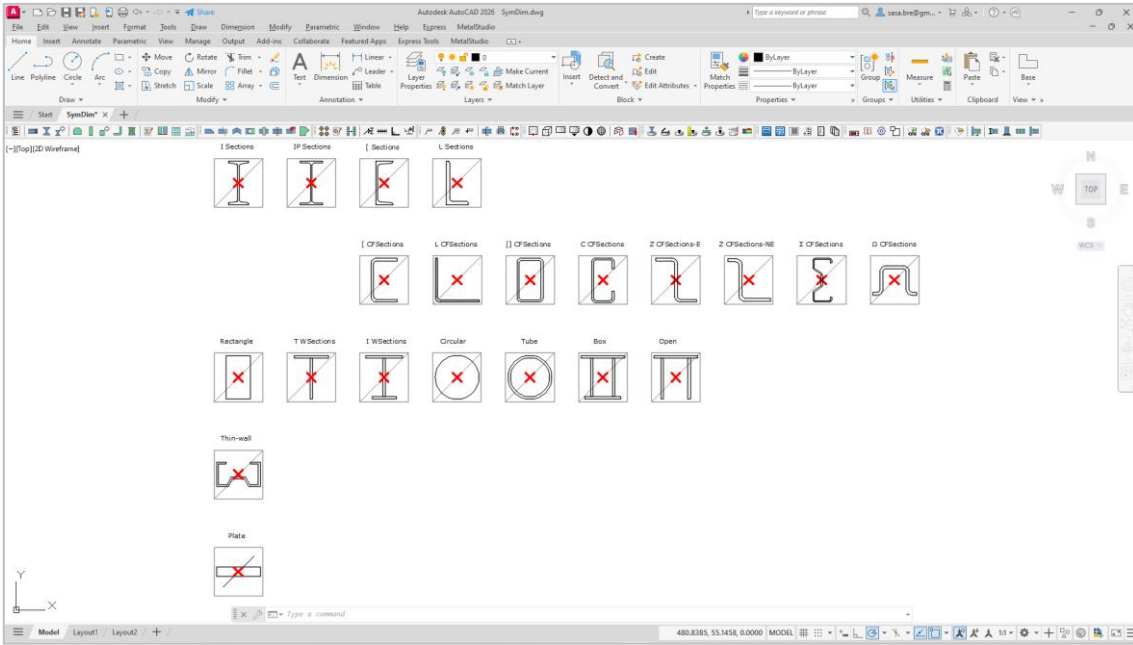

Symbols located in the 'SymBolt.dwg' database should be drawn so that 1ACU=1mm, whereas when creating a block, the center of the symbol should be chosen for the reference point.

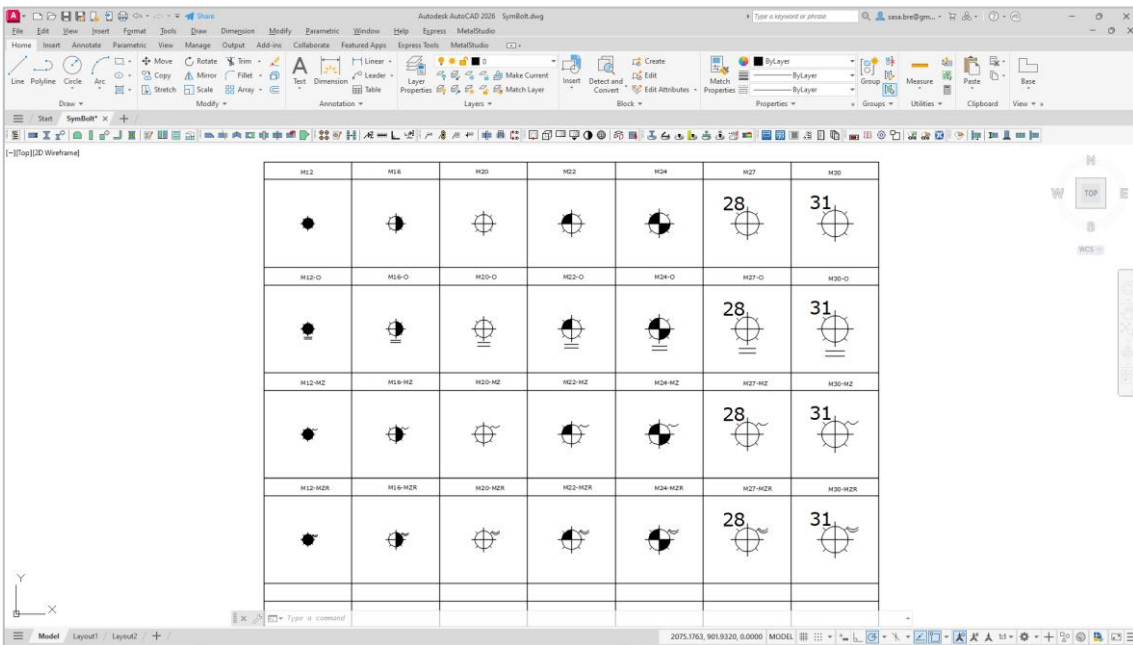

The symbol bounding box in the 'SymWeld.dwg' database should not be greater than 30x20 AutoCAD units (ACU), whereas when creating a block the bottom left corner of the bounding box should be chosen for the reference point. In symbols which are delivered with the program, the bounding box is displayed as a rectangle in grey color, whereas the reference point is marked with a small red cross.

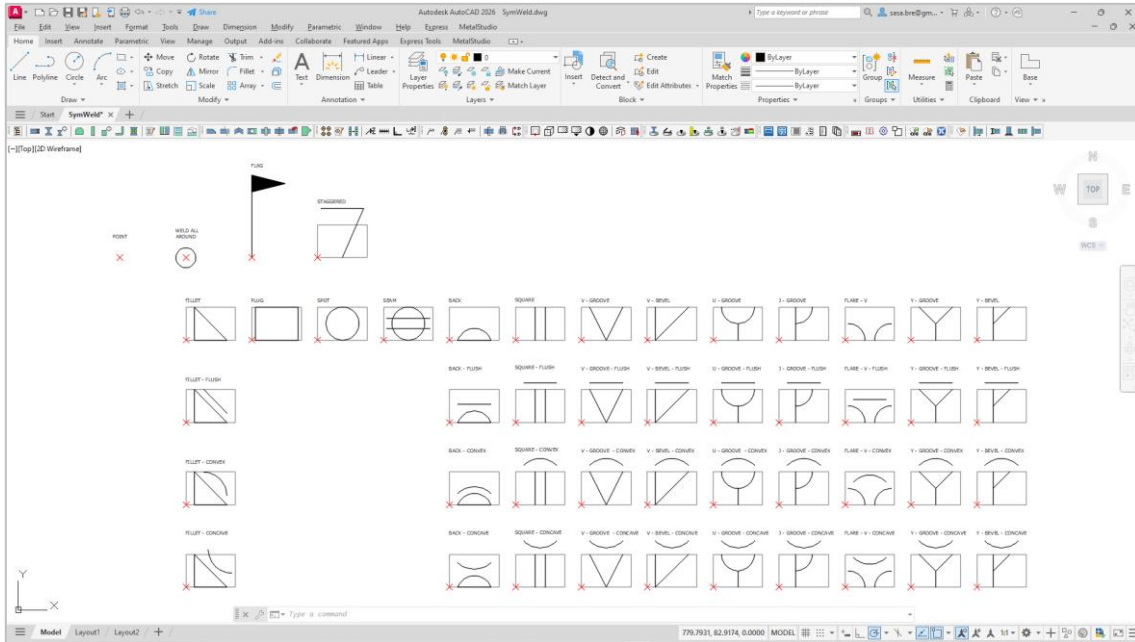

It is also possible to create completely new databases with symbols in addition to changing the existing ones. Selecting databases to be used during working with the program is performed in the dialog box within the 'Functionality' command.

2. ASSEMBLY POSITIONS

2.1 Assembly positions

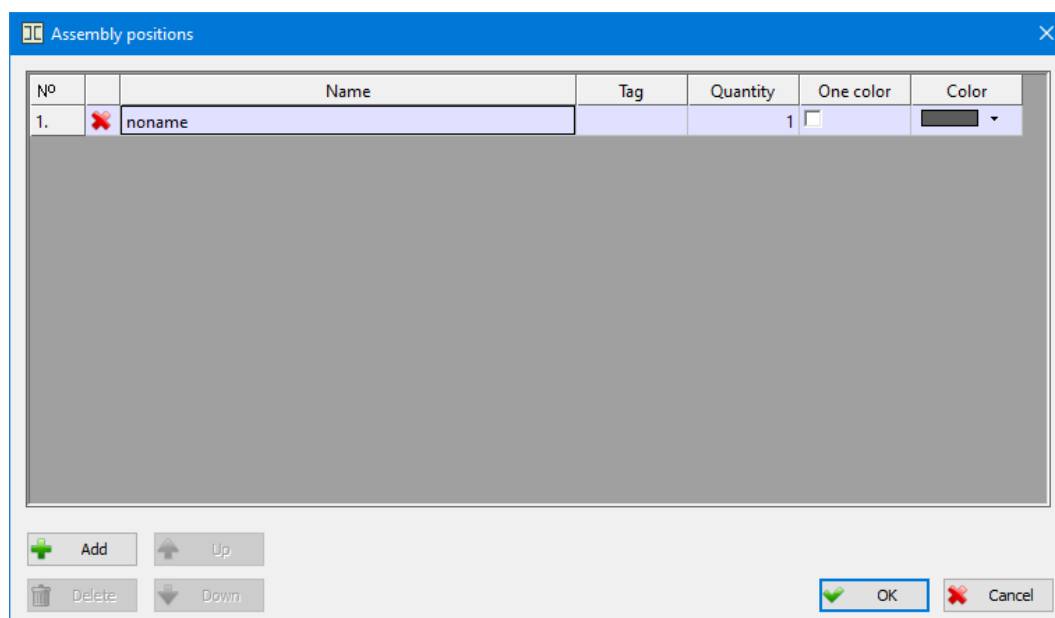

Either by selecting the 'Assembly positions' command from the 'Metal Studio' drop-down menu or by clicking on the icon , a dialog box of the following layout will open up:



The dialog box for defining assembly positions - the layout

The central part of the displayed dialog box contains a list of all assembly positions contained in the drawing. Here, the term 'assembly position' refers to the name of the structural element to which entities which will be drawn later will be added. Assembly position is not visible in the drawing (it is physically intangible) and it mainly serves for grouping entities which are being drawn into whole groups.





N° The column contains assembly positions (ordinal) numbers.

Name The column contains names of all assembly positions. Whenever a new drawing is opened, the program will automatically create an assembly position and by default add a no-name to it. On the left of the assembly position name, there is a marker which marks whether a given assembly position has been allocated a girder or a plate position or not. The  symbol denotes that the assembly is empty, whereas the  symbol denotes that at least one entity has been allocated to the given assembly position.

Tag The edit box for entering the assembly position tag. This tag can be displayed in the labels of the entities being part of that assembly.

Quantity The edit box for entering the value by which all girders and plates quantities will be multiplied during generating the specification.

One color When this check box is turned on, all material and immaterial instances of positions being part of that assembly, are being drawn with the color assigned in the 'Color' column.

- Color** The box for selecting the color, which will be used for drawing all material and immaterial instances of positions being part of that assembly, when the monochromatic displaying for that assembly position is turned on.
-  **Add** The button upon activating which a new assembly position is added to the list.
-  **Delete** The button upon activating which the currently selected assembly position is removed from the list.
-  **Up** The button upon activating which the placing of the currently selected assembly position is changed by moving upwards in the list.
-  **Down** The button upon activating which the placing of the currently selected assembly position is changed by moving downwards in the list.

Upon selecting the '**OK**' button, the dialog box will close, whereas the currently selected assembly position in the list will become the current one. In other words, all entities to be drawn further on will be added to the currently set assembly position.

3. GIRDERS

3.1 New girder in plan view

Either by selecting the 'New girder in plan view' command from the 'Metal Studio' drop-down menu or by clicking on the icon , a dialog box for creating a new girder position will open up:

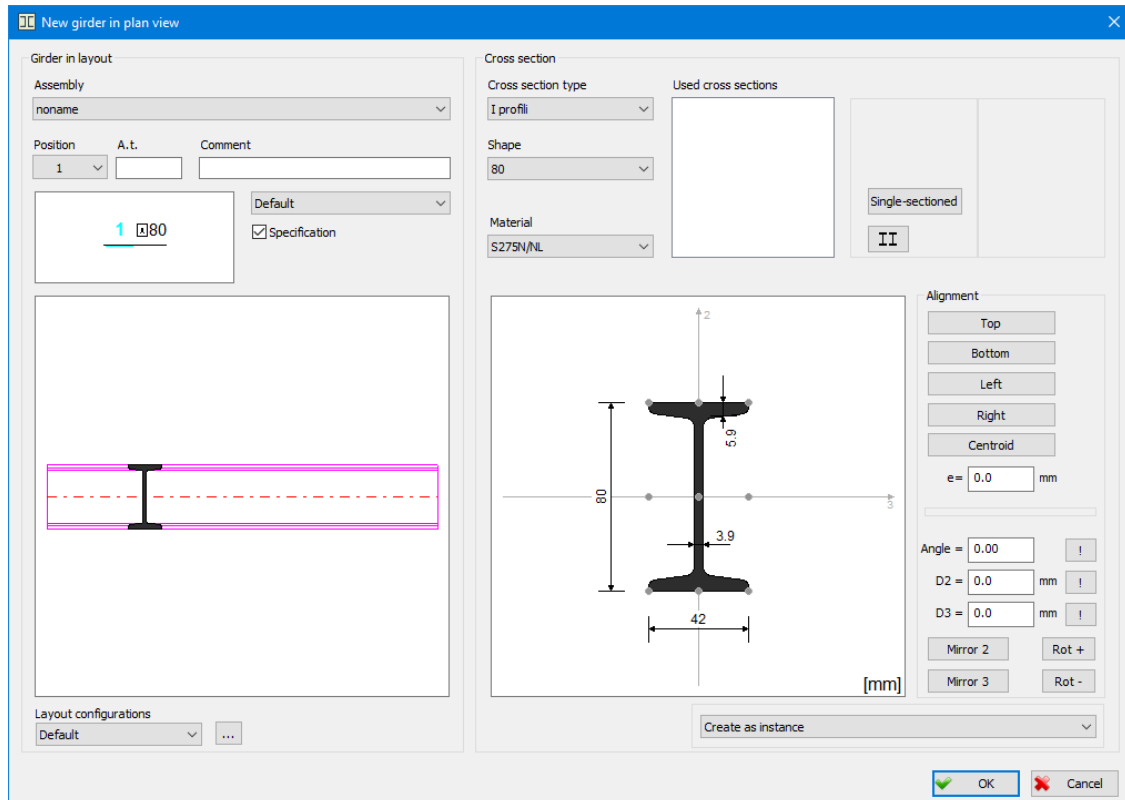

The dialog box for defining the girder in plan view - the layout

The dialog box is divided into two parts, so that the right part is intended for defining the girder cross section whereas the left part contains the layout of the girder in plan view for the selected cross section and all data related to the given position.

Assembly The combo box for selecting one of the previously defined assembly positions.

Position The combo box displays all free positions corresponding to the currently set assembly position. Any position from the combo box can be set as the current one. It is, however, necessary to emphasize that only the position which is unoccupied by either girders or plates can be referred to as a free position.

A.t. The edit box for entering an additional girder position tag which will be written in the label text (placing it in the label will be described in the chapter 'Parameters').

Comment The edit box for assigning an arbitrary comment of the girder position which will be written in the label text.

Labeling style From the combo box, you can select any of the previously defined configurations of labeling styles. The preview on the left of the combo box displays the label layout corresponding to the selected style.

Specification The check box from which you can define whether a girder will be included in the specification or not.

Layout configurations

The combo box for selecting any of the previously defined configurations of entities layout which will also be applied to all girders to be drawn further on.



The button upon activating which the 'Entity layout' dialog box will open up. Using this dialog box allows you to change the current girder layout (working with this dialog box will be described in more detail in chapter 9.3).

Selecting a girder placing style

The list under the layout of girder cross sections, allows you to select the way of placement for the girder. Upon choosing '**Create as instance**' option, material instance of the girder in plan view is being placed in the drawing. Upon choosing '**Create as represent of arbitrary geometry**', girder represent is being placed in the drawing. Represent is an entity showing girder in plan view, and its geometry may differ from the geometry of girder position, with cross section of girder position and cross section of represent being always identical. When represent is being placed in the drawing, using this command, its geometry also creates girder position geometry, but all the additional modifications of represent geometry will not have an impact on girder position geometry.

Defining girder cross section

Cross section type

The combo box for selecting the cross section type. The combo box contains all types of rolled shapes from the database of shapes (I, IPE, ...) and standard cross sections (rectangular, T-section, ...) which are defined by assigning their dimensions. Upon selecting one of the offered cross sections in the combo box, the layout of the selected cross section with all required data labeled will be displayed in the right part of the dialog box.

Decompose into plates

Check box, which is available solely in case a standard cross section from the list is chosen (T-section, I-section, box cross section, opened cross section). Enabling the check box allows such cross sections to be decomposed into flat plates. Physically observed, a new girder array of the rectangular cross sections, is created from the girders of these cross sections.

Shape

The combo box contains all rolled shapes of a certain type for which data exist in the database. It is possible to create from certain shapes multiple cross sections, by selecting appropriate buttons. If one of the standard cross sections in the box is selected for the cross section type, this combo box will be inactive.

Material

The combo box for selecting one of the previously defined steel types.

Used cross sections

The combo box contains a list of all cross sections located in the drawing and sorted by assemblies to which they belong. If you right-click on one of the used cross sections, a drop-down menu with the **'Add to the most frequently used'** option will open up. If you select this option, the selected cross section will be automatically inserted in the list of the most frequently used cross sections. Whenever a new file is opened, this list will be loaded too. If you want to remove one of the cross sections from the list, first you must select it and then choose the **'Delete from the most frequently used'** option from the drop-down menu which opens up upon right-clicking.

Alignment

Cross section alignment can be performed in two ways: either by selecting one of the offered points which are arranged along the cross section bounding box located in the right drawing, by which the girder local coordinate system will be automatically placed in the selected point, or by assigning value in appropriate edit boxes.

Top Upon selecting this command, the cross section will be moved so that its top is found at the assigned distance 'e' from the girder local coordinate system.

Bottom Upon selecting this command, the cross section will be moved so that its bottom is found at the assigned distance 'e' from the girder local coordinate system.

Left Upon selecting this command, the cross section will be moved so that its left edge is found at the assigned distance 'e' from the girder local coordinate system.

Right Upon selecting this command, the cross section will be moved so that its right edge is found at the assigned distance 'e' from the girder local coordinate system.

Centroid Its purpose is to cancel all previously assigned alignments and put the cross section centroid into the default placing, so that it corresponds to the girder local coordinate system. The currently set value in the edit box 'e=' does not affect activating this button.

Angle The edit box for entering the angle by which the cross section will be rotated (the angle positive orientation increases in the anticlockwise direction).

D2 The edit box for assigning the distance of the cross section centroid from the local coordinate origin in the direction of the local axis '2'.

D3 The edit box for assigning the distance of the cross section centroid from the local coordinate origin in the direction of the local axis '3'.



The button upon activating which taking directly from the drawing is made possible and selecting two points whose mutual spacing will determine the required value to be placed in an appropriate edit box.

Mirror 2 The button upon activating which a mirrored transformation of the selected cross section is obtained, whereas copying is performed around the local axis '2'.

- Mirror 3** The button upon activating which a mirrored transformation of the selected cross section is obtained, whereas copying is performed around the local axis '3'.
- Rot +** The button upon activating which the cross section is rotated by an angle of 45 degrees in the anticlockwise direction.
- Rot -** The button upon activating which the cross section is rotated by an angle of 45 degrees in the clockwise direction.
- Edit** The button upon activating which a dialog box for editing thin-wall cross sections will open up. This button becomes active only when one of the thin-wall cross sections has been selected from the 'Cross section type' box.

The right part of the dialog box displays the selected cross section and its local axes, whereas the top left corner of the drawing displays the coordinates of the current mouse position in relation to the local coordinate origin.

Activating the '**OK**' button will result in starting the procedure of placing one or several girder instances to which all data assigned in the dialog box will be added, and the command bar will obtain the following layout.

First point (detached input) [Polyline/Rectangle/Circle/Continuous input/End] <End>:

Detached input

When this method of drawing is active, it is possible to draw a large number of girders which do not have to be continued on one another, so that the beginning of the next girder does not have to be in the end point of the previously drawn one. The program automatically assigns a position number to every girder.

Continuous input

When this method of drawing is active, all girders are mutually connected, and drawing is done in such a way that the end point of the previously drawn girder represents the beginning point of the next girder, which is actually drawing a polyline. Each polyline segment represents a single girder, and to every one of them, the program automatically assigns a position number.

Polyline The girder geometry is defined by selecting an arbitrary polyline from the drawing.

Rectangle Drawing girders of a rectangular shape.

Circle Drawing girders of a circular shape.

If you have decided to define the girder geometry by drawing an arbitrary polyline, after selecting the first point, a new message will appear on the command bar:

Next point [Arc/Back]:

Arc Intended for drawing arch girders.

Back Intended for cancelling the selection of the first point.

Upon selecting the '**End**' command, the command will end, and all data assigned in the dialog box will be added to all drawn girders.

3.2 New girder in cross section

Either by selecting the 'New girder in cross section' command from the 'Metal Studio' drop-down menu or by clicking the icon , a dialog box for creating a new girder position will open up. After creating a new girder position, you can start the procedure of placing a single or multiple instances of girder, that can be placed on the drawing, depending on the user requirements, as the lateral plan views of girder or material instances perpendicular to the drawing plane.

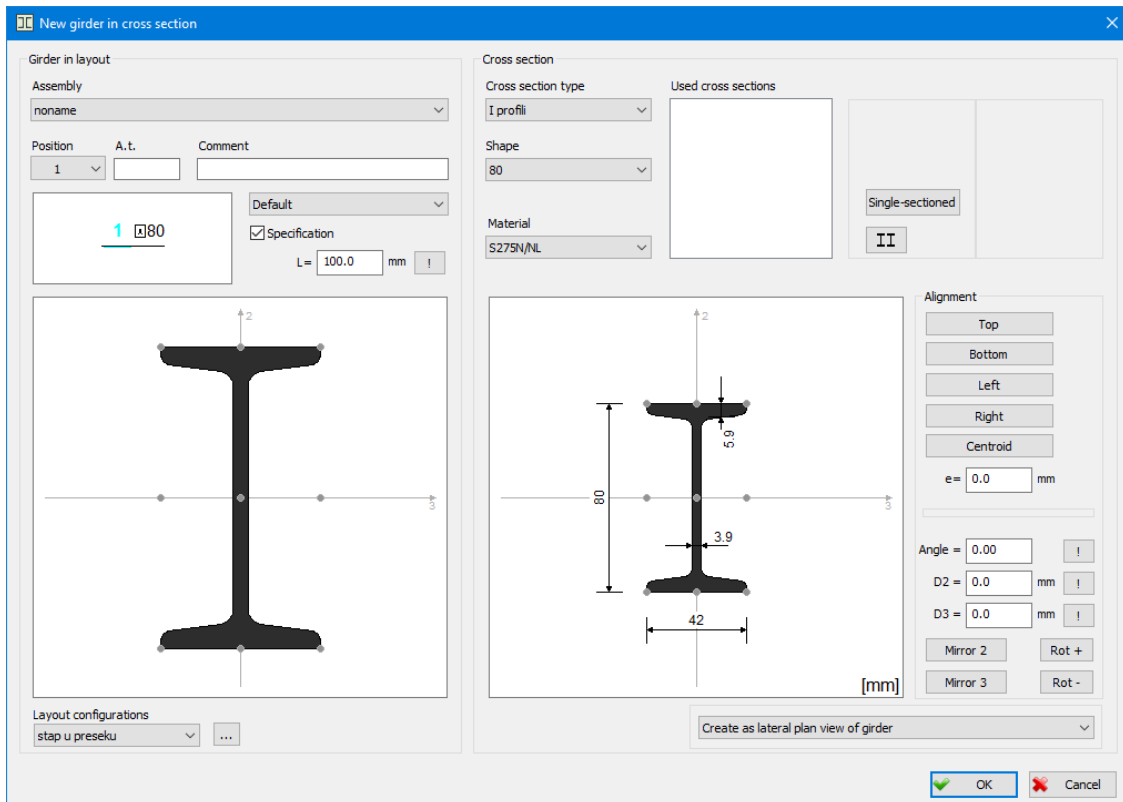

The dialog box for defining a girder in cross section - the layout

The dialog box is divided into two parts, so that the right part is intended for defining the girder cross section whereas the left part displays lateral plan views of girder as well as all data related to the given position.

Working within this dialog box is identical to working within the dialog box for defining a girder in cross section, which is why it will not be described here again.

'L=' The edit box for assigning the length of girder in cross section.



The button upon activating which taking directly from the drawing is made possible and selecting two points whose mutual spacing will determine the required value to be placed in an appropriate edit box.

Upon selecting one of the options from the combo box under the right drawing, it will be determined whether immaterial or material instances of girders are being placed in the drawing:

Create as lateral plan view of girder

Immaterial instance of the girder is being placed in the drawing, i.e. the instance representing a lateral plan view of girder.

Create as girder perpendicular to drawing plane

Material instance of the girder, perpendicular to the drawing plane, is being placed in the drawing.

Once you have defined the cross section, you must select a reference point for placing the girder in the drawing, by selecting one of the offered points arranged along the cross section bounding box located in the left part of the dialog box. The selected reference point will be marked in red.

Activating the 'OK' button will result in starting the procedure of placing the girder to which all data assigned in the dialog box will be added, and the program will request from the command bar that you define the position of the reference point in the drawing.

Reference point [End] <End>:

Once you have assigned the reference point, the command bar will obtain the new layout, and the program will request that you enter the angle of the girder inclination with respect to the horizontal:

Angle [End] <End>:

This command has got a circular quality which means that the user will be requested again to enter the reference point and the angle, and the command is exited upon selecting the 'End' sub-option from the command bar.

3.3 Existing girder

The 'Existing girder' command is used when it is necessary to place the instance of the previously created girder position in another place in the drawing. Either by selecting this command from the 'Metal Studio ► Existing girder' drop-down menu or by clicking on the icon , a dialog box of the following layout will open up:

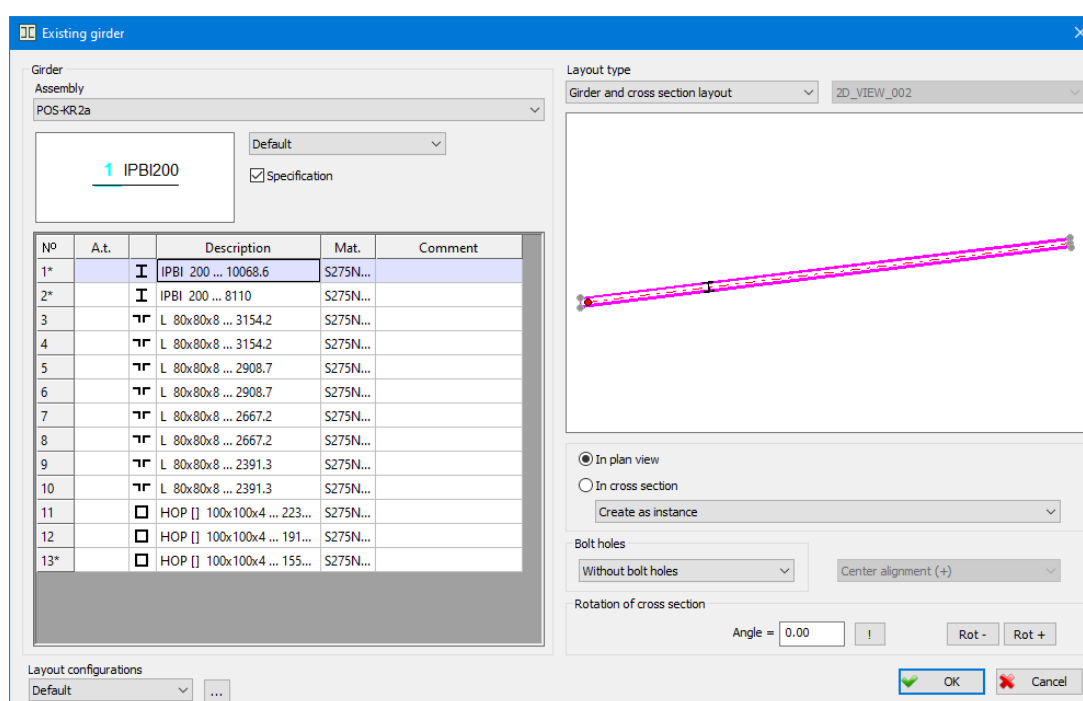

The dialog box for selecting the existing girder position - the layout

- Assembly** The combo box which allows you to set as the current one any of the previously defined assembly positions.
- Labeling style** From the combo box, you can select any of the previously defined configurations of labeling styles. The preview on the left of the combo box displays the label layout corresponding to the selected style.
- Specification** The check box which allows you to define whether a girder will be included in the specification or not.

The left part of the dialog box displays a list containing all previously defined girder positions within the current assembly position.

- N°** The column contains assembly positions (ordinal) numbers. For the girder positions with sub-positions (instances belonging to the same position, which can differ from one another only by the positions of holes from bolt series), the symbol `*` will show next to the ordinal number.
- A.t.** The edit box for entering an **additional girder position tag** which will be written in the label text.
- Description** This column allows you to write the girder position type, tag and length. In front of this column, there is a column with the given cross section symbol. This latter column is marked in pink if the girder quantity equals zero.
- Mat.** This column displays steel type.
- Comment** The edit box for assigning an arbitrary girder position comment which will be written in the label text.

In the right part of the dialog box, there is a window which is intended for displaying the selected girder position.

- Layout type** This combo box allows you to place as the current one any of the three methods intended for displaying the selected position.
- Girder and cross section layout** – displays the layout and cross section of the selected girder position.
 - Elements from the current assembly** – displays the instances of all girder positions from the current assembly, whereas the placing of instances of the selected position is clearly marked.
 - All elements** – displays the instances of all girder positions from all assembly positions, whereas the placing of instances of the selected position is clearly marked.
- If you are in the '3D Modeling' operating mode, and the display of elements from the current assembly or all elements is selected from the list, a list will become available from which you can select one of the views that are set in the viewports. Then the position of instances in the selected view will be displayed in the window.

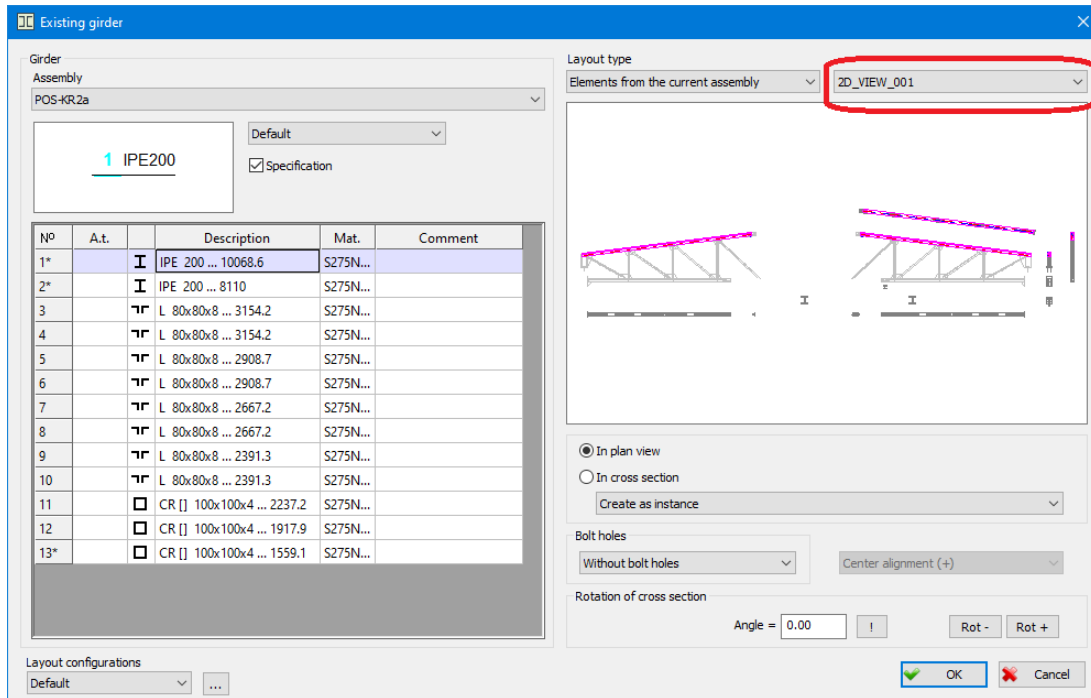

A list of view names that are set in viewports

In plan view

The switch upon selecting which the selected girder position will be placed in the drawing as the girder in plan view. Selecting a girder placing style is being performed from the combo box. Upon choosing the **'Create as instance'** option, material instance of the girder in plan view is being placed in the drawing. Upon choosing the **'Create as instance plan view'**, immaterial instance, i.e. 2D picture of material instance in plan view. Upon choosing the **'Create as represent of arbitrary geometry'**, girder represent is being placed in the drawing.

In cross section

The switch upon selecting which the selected girder position will be placed in the drawing as the girder in cross section. Selecting a girder placing style is being performed from the combo box. Upon choosing the **'Create as lateral plan view of girder'** option, immaterial instance of the selected position, which is the lateral plan view of girder, is being placed in the drawing. Upon choosing the **'Create as girder perpendicular to drawing plane'**, material instance of the selected girder position, perpendicular to drawing plane, is being placed in the drawing.

If the option 'Create as girder perpendicular to drawing plane' is selected, a list will become available from which it is possible to choose one of the offered girders alignments in relation to the plane of the current view.

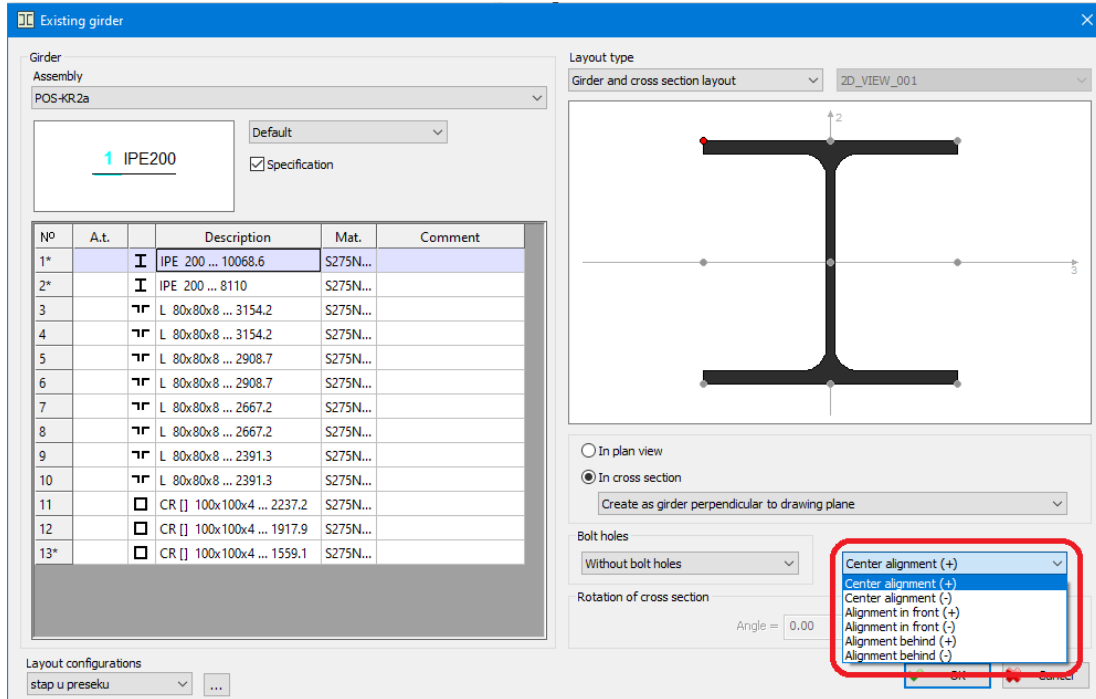

A list for selecting the alignment of the girder relative to the plane of the current view

Bolt holes

Upon selecting appropriate option from the combo box, instance without holes from bolt series may be placed in the drawing, as well as instance with the same hole order as any other instance of the given position in the drawing. In case none of the instances of the selected position has holes from bolt series, this combo box is not available. Also, the combo box is unavailable when choosing represent in plan view or lateral plan view of girder and placing it in the drawing.

Angle

The edit box for entering the angle by which the cross section will be rotated (the angle positive orientation increases in the counterclockwise direction).



The button upon activating which taking directly from the drawing is made possible and selecting two points whose mutual spacing will determine the required value to be placed in an appropriate edit box.

Rot -

The button upon activating which the cross section is rotated by an angle of 90 degrees in the clockwise direction.

Rot +

Button upon activating which the cross section is rotated by an angle of 90 degrees in the counterclockwise direction.

Layout configurations

The combo box for selecting any of the previously defined configurations of entities layout which will also be applied to all girders to be placed further on.



The button upon activating which the 'Entity layout' dialog box will open up. Using this dialog box allows you to change the current entity layout.

In the window which displays the selected girder position you must select the reference point, by clicking one of the offered points arranged along the girder bounding box. The selected reference point will be marked with a red symbol.

Upon activating the '**OK**' button, the program will close the dialog box and request from the command bar that you define the position of the reference point in the drawing.

Reference point:

Once you have assigned the reference point, the command bar will obtain a new layout, in which the user is requested to enter the angle of the girder inclination with respect to the horizontal:

Angle:

If a represent is placed in the drawing, the position of the mouse during assigning the angle will define its length. The represent length can also be assigned from the command bar.

4. PLATES

4.1 New plate in plan view

Using this command allows you to create a new plate position and place in the drawing the plate instance which is seen in plan view. The plate geometry is assigned either by drawing an arbitrary polyline or by selecting one of the options offered on the command bar.

First point [Polyline/Rectangle/Circle]:

Polyline The plate geometry is assigned by selecting an arbitrary polyline from the drawing.

Rectangle Drawing plates of a rectangular shape.

Circle Drawing plates of a circular shape.

Once you have defined the plate geometry, you can select from the drawing an existing girder or a plate with which it will be aligned by depth, and the command bar will obtain a new layout:

Selecting entities for alignment [Exit] <Exit>:

Selecting an entity for plate alignment can be performed subsequently from the dialog box of this command.

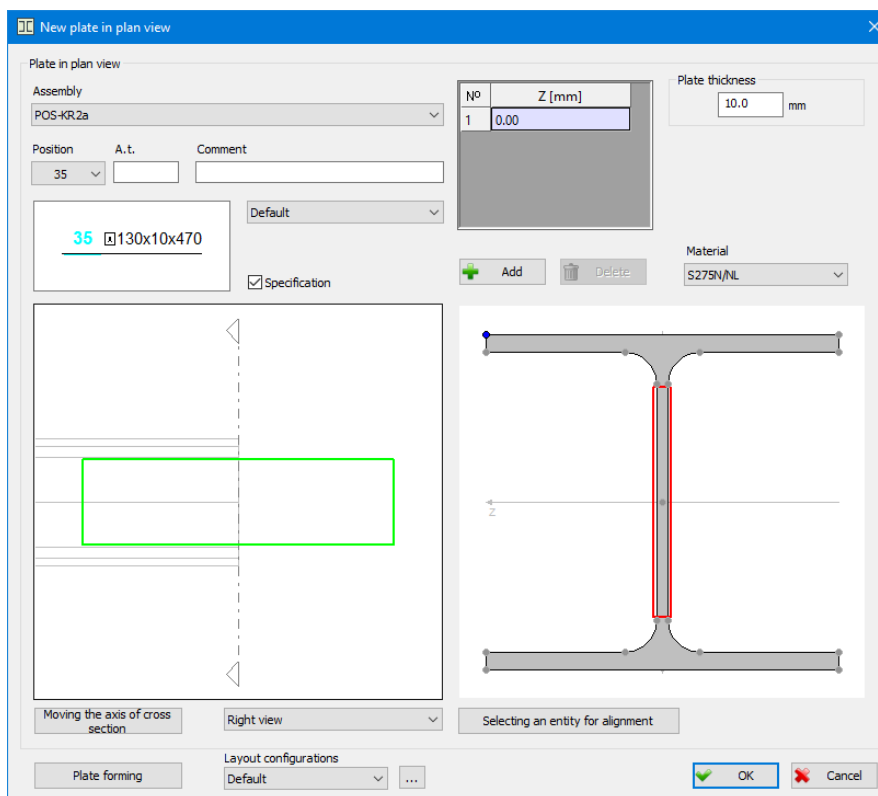

The left drawing in the dialog box displays the assigned plate geometry, the entity for alignment and the placing of cross section which is displayed in the right drawing.

- Assembly** This combo box allows you to set as the current one any of the previously defined assembly positions.
- Position** This combo box displays all free positions corresponding to the currently set assembly position. Any position from the list can be set as the current one.
- A.t.** The edit box for entering an arbitrary text (**additional tag**) which will be added to the plate position number. The placing of an additional tag in relation to the position number is assigned in the dialog box of the 'Parameters' command. There are three options: before, after and instead of the position number. The same parameters of layout which apply to additional tag apply to the position number.
- Comment** The edit box for entering an arbitrary comment which can be displayed in the plate label.
- Labeling style** From the combo box, you can select any of the previously defined configurations of labeling styles. The preview on the left of the combo box displays the label layout corresponding to the selected style.
- Specification** The check box the state of which determines whether a plate will be included in the specification or not.

Plate thickness

The edit box for assigning plate thickness.

Material

The combo box for selecting a plate material. The list can be supplemented via the 'Database of structure materials' command.

Z [mm]

Using the 'New plate in plan view' command allows you to place simultaneously in the drawing multiple parallel instances of the created plate position. All instances are displayed in the table in which the current instance is marked with a special color. Alignment by depth is performed independently for each of them, either by entering the distance between the instance and the drawing plane into an appropriate field in the 'Z [mm]' column or by selecting points from the drawing on the right. The latter method will be explained in more detail further on in the text.



Add

The button upon activating which a new plate instance is inserted into the table.



Delete

The button upon activating which a new plate instance is removed from the table.

Moving the axis of cross section

Since it can quite easily happen that the axis of cross section does not go over the entity for alignment, moving it is also possible. First, you must activate the 'Moving the axis of cross section' button upon which the axis turns red, and then, by selecting a point from the left drawing, you must define the new position of the axis of cross section. Please note that the axis of cross section must intersect the assigned plate.

Selecting the view

The combo box, which is below the left drawing, allows you to select one of the offered cross section planes, as well as its plan view. Its contents depend on the position of the plate in the drawing.

Selecting an entity for alignment

The button upon activating which taking directly from the drawing is made possible and selecting an entity for alignment.

Plate alignment by selecting points from the right drawing

In all intersection points of the contour segments of the entity for alignment, small circles are placed. One of the circles is always marked with a special color, which means that this point is currently selected as the reference point for plate alignment. Changing the reference point is performed by moving and placing the mouse pointer over one of the circles and when it changes its color, you must press the left mouse button. When the mouse pointer is placed over one of the circles in the top left corner of the drawing, the program displays the distance in the direction of the Z axis between it and the reference point. The plate instance which has been selected in the table is displayed in this drawing in a special color and only it can be aligned with the selected reference point. Alignment is performed by moving and placing the mouse pointer over one of the contour segments of the current plate instance and when it changes its color, you must press the left mouse button. In addition to contour segments, the plate axis can also be selected for alignment.

Layout configurations

The combo box for selecting any of the previously defined configurations of entities layout.



Clicking this button will result in opening a dialog box for defining configurations of entities layout. Working with this dialog box will be described in more detail in the chapter 'Entity layout'.

Plate forming Clicking this button will result in opening a dialog box which allows you to change the geometry of the created plate. Working with this dialog box will be explained in more detail later on in the chapter 'Plate forming'.

4.2 New plate in cross section

Using this command allows you to create a new plate position and place in the drawing the plate instance whose plane is perpendicular to the drawing plane. Having in mind the way plates are displayed, assigning an arbitrary geometry is not possible. It is, however, possible to create a plate initially as a rectangle and change its geometry in the dialog box of the command. Upon activating this command, the program will request from the command bar that you assign the plate length and thickness, by selecting two points in the drawing. Other required data are entered in the floating dialog box which opens up at the same time.

Plate in cross section – first point:

The image shows a dialog box titled "Plate input". At the top, there are two radio buttons: "Axially" (which is selected) and "By edge". Below these, there are two input fields: "Plate thickness" with the value "8.0" and "mm", and "Plate width" with the value "80.0" and "mm".

Axially

When this option is selected, you can define the position and the length of the plate axis in the cross section by assigning points from the drawing.

By edge

When this option is selected, you can define the position and the length of one edge of the plate in the cross section by assigning points from the drawing. Since the program does not know which edge it is, you must select by clicking on which side of the assigned edge the plate is:

Orientation [Back]:**Plate thickness**

The edit box for assigning plate thickness.

Plate width

The edit box for assigning plate width.

Once you have defined the plate geometry, you can select from the drawing an existing girder or a plate with which it will be aligned by depth, and the command bar will obtain a new layout:

Selecting entities for alignment [Exit] <Exit>:

Selecting an entity for plate alignment can be performed subsequently from the dialog box of this command.

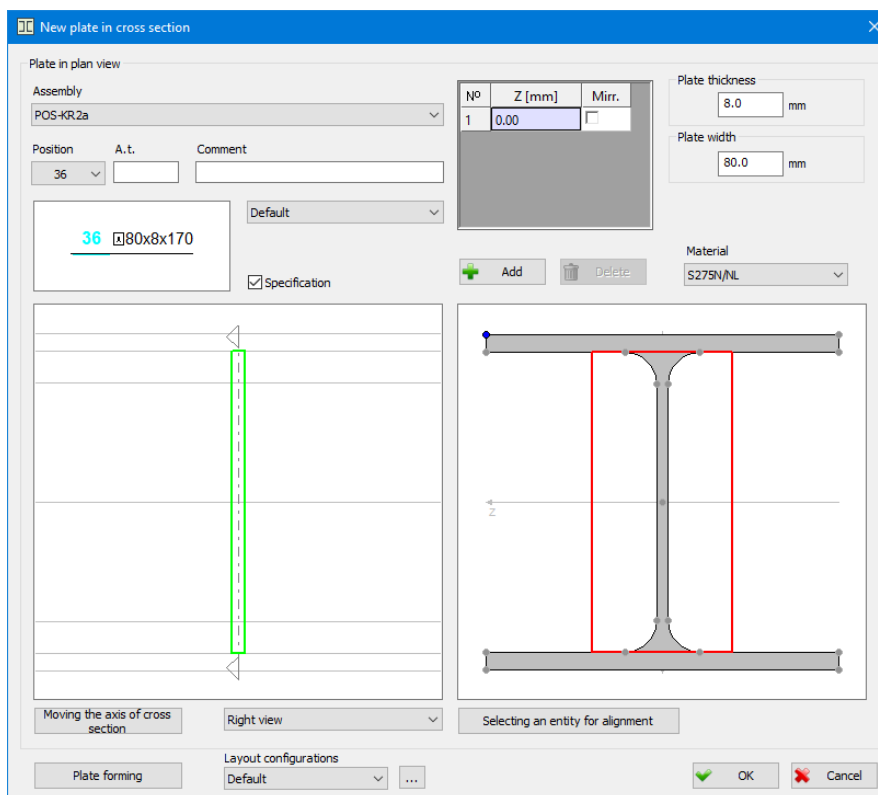

This dialog box works in the same way as the dialog box within the 'New plate in plan view' command. The new piece of data is '**Plate width**', and this edit box enables you to change the width of the created plate which has been previously assigned in the floating dialog box. The other difference lies in the table which now includes the '**Mirr.**' column (Mirror). If you turn on the check box 'Mirr.', you will get the mirrored transformation of the selected plate.

Shortening of the plate axis

In case an inclined girder (girder edges are at an angle with respect to the horizontal) is chosen to represent the entity for alignment, the program allows for the vertical plates for the web stiffening to be matched between the flanges of that shape, by the shortening of the plate axis. The matching is performed by placing the mouse pointer above the segment representing the plate thickness; when an intermittent line appears below it, user should press the right mouse button, where a drop-down menu with two commands will show up: **'Shortening of the plate axis'** and **'Canceling the previous shortening'**.

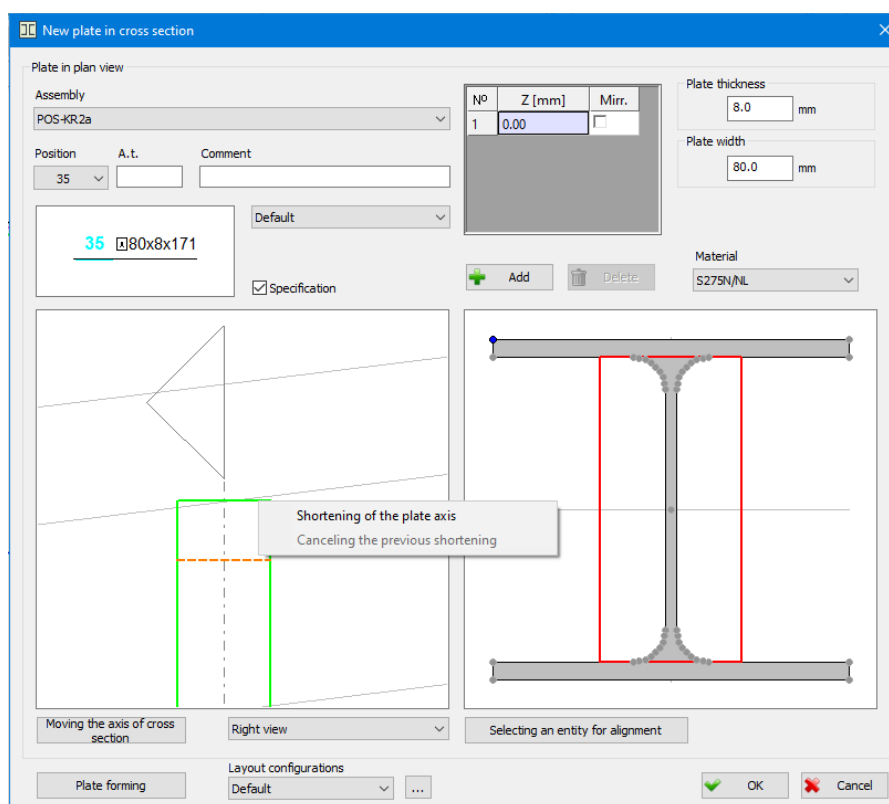

Plate layout in cross section prior to activating the command for the shortening of the plate axis

Canceling the previous shortening

This command is available within the menu solely in case the shortening of the plate axis was performed, and by selecting it, the last shortening will be canceled.

Shortening of the plate axis

By selecting this command from the menu, a dialog box for the style adjustment for the shortening of the plate axis.

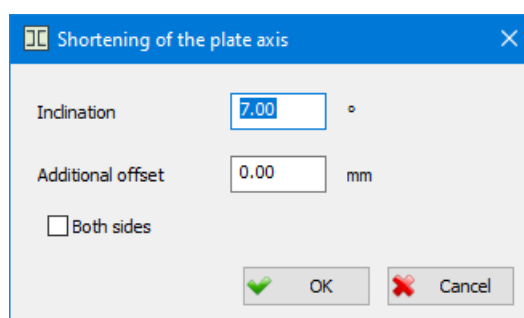

Inclination The edit box where the program automatically writes the values of the inclination of the girder selected for the plate alignment, based on which the plate axis will be shortened in order to perform the matching of the plate flange of that shape. Where necessary, the user is allowed to independently alter this inclination, by entering the required value into the edit box.

Additional offset

The edit box for assigning the additional offset of the plate axis. Entering the additional offset will firstly shorten the plate axis, in the way that it is matched to the flange, and afterwards, it will additionally offset for the entered value in this edit box. Entered positive value indicates the shortening of the plate, whereas negative value results in the extension of the plate axis.

Both sides Enabling this check box will result in the shortening of the plate axis on the both sides.

Upon exiting the dialog box by pressing '**OK**', the shortening of the plate axis will be performed, based on the parameters adjusted in this dialog box.

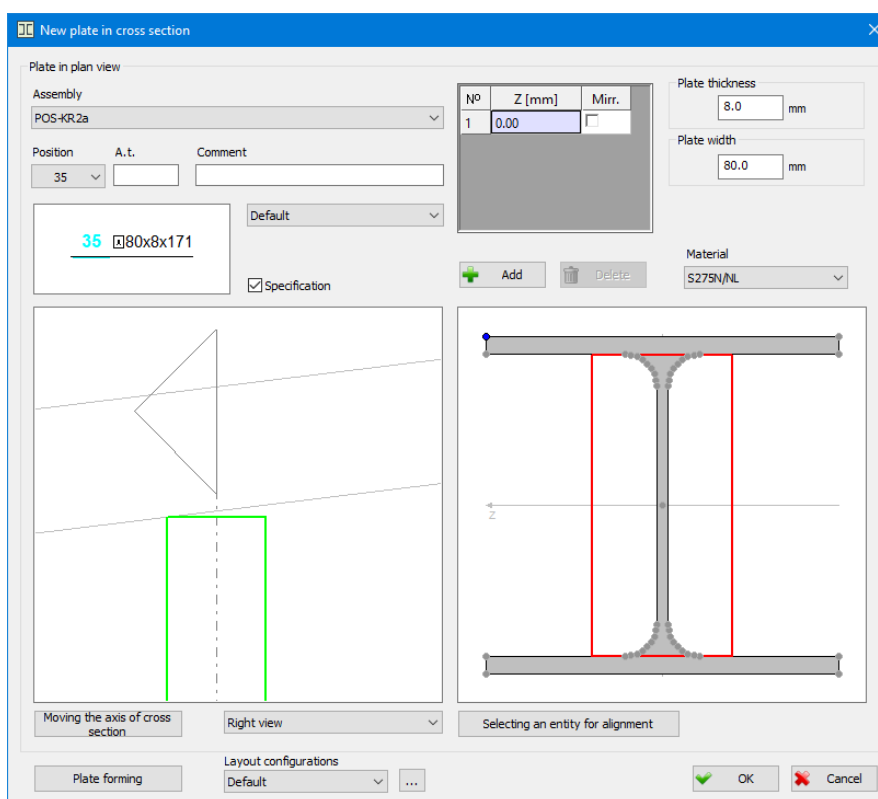
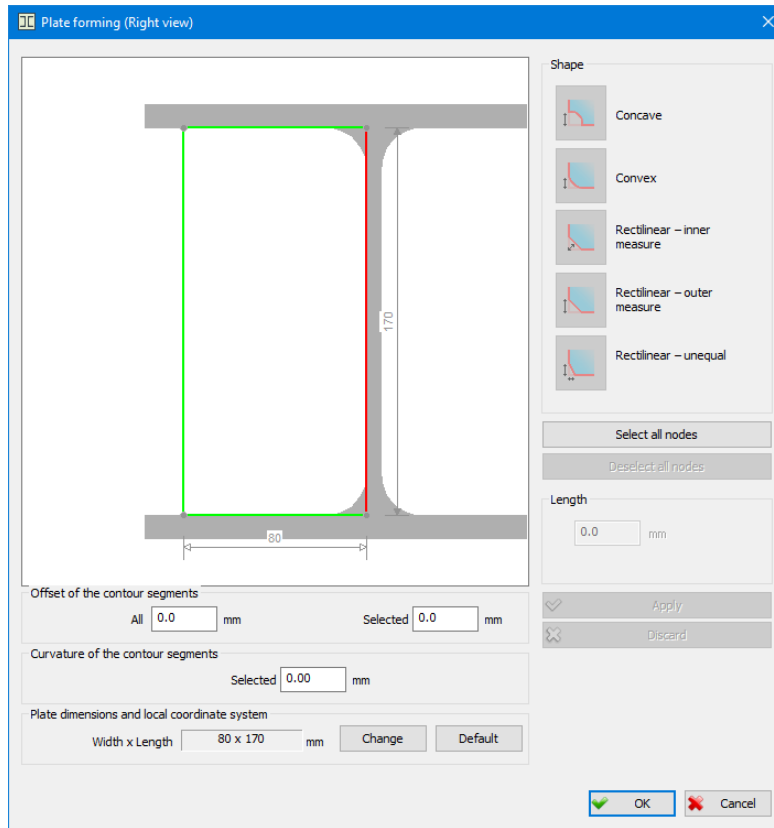

Plate layout in cross section after the shortening of the plate axis

One of the possible ways for the additional alteration of the plate geometry in the cross section, i.e. the alteration of the plate axis length, is the stretching of the grips, placed in the corners of the plate by the program, upon its selection in the drawing. As a remark, all the formings already present on the plate in the cross section, are lost after the stretching of the grips.

4.3 Plate forming



This dialog box can be called from the dialog boxes of the commands 'New plate in plan view', 'New plate in cross section' and 'Database of positions', and its purpose is to enable changing the plate geometry subsequently.

Offset of the contour segments:

All The edit box for assigning the offset of all contour edges of the plate.

Selected The edit box for assigning the offset of the selected plate contour segment. Selecting the segment is performed by moving and placing the mouse pointer over one of the plate contour segments and by pressing the left mouse button. The selected segment is marked in the drawing with a special color.

Curvature of the contour segments

Selected The edit box for assigning the arch rise of the selected plate contour segment. Entering the positive value results in linear segment transforming into the convex arch segment; entering the negative value results in transforming into the concave arch segment; finally, entering the zero value results in arch segment changing into the linear.

Forming angles:

Selecting plate angles from the drawing

In order to perform forming of a plate angle, it is necessary to select it first. Selecting is performed by placing the mouse pointer over one of the circles which are found on all refraction points of the plate contour and by pressing the left mouse button. In order to enable selecting multiple angles simultaneously, it is necessary to hold down the Shift key during selecting. Deselecting one of the previously selected angles is performed in much the same way.



Concave forming of the selected angles. In other words, those contour segments from which the selected angle is formed are shortened by the value entered in part of the dialog box 'Length' and a new concave arch segment is inserted between them.



Convex forming of the selected angles. In other words, those contour segments from which the selected angle is formed are shortened by the value entered in part of the dialog box 'Length' and a new convex arch segment is inserted between them.



Rectilinear – inner measure. In other words, those contour segments from which the selected angle is formed are shortened so that the net free space is not less than the value entered in part of the dialog box 'Length' and a new rectilinear segment is inserted between them.



Rectilinear – outer measure. In other words, those contour segments from which the selected angle is formed are shortened by the value entered in part of the dialog box 'Length' and a new rectilinear segment is inserted between them.



Rectilinear – unequal. This option is available only when one plate angle is selected. When you select this option, those contour segments from which the selected angle is formed are marked in different colors in the drawing, and for each of them you must enter different lengths of shortening in part of the dialog box 'Length'. After shortening, a new rectilinear segment is inserted between them.

Select all nodes

The button upon activating which all plate angles are selected.

Deselect all nodes

The button upon activating which all previously selected plate angles are deselected.

Length

Part of the dialog box in which the lengths of shortening plate contour segments are assigned.

Apply

The button upon activating which the selected plate angles are formed according to the assigned parameters.

Discard The button upon activating which all geometry changes which have been previously done on the selected plate angles are now cancelled.

Plate dimensions and local coordinate system:

Width x Length

Here you can write the dimensions of the plate bounding box.

Change

The button upon activating which the plate LCS is changed. The rule according to which the plate LCS is changed is very simple - one of the axes of the plate LCS must always be parallel with one of the plate contour segments.

Default

Reverting the plate LCS to the initial state.

4.4 Existing plate

Using the 'Existing plate' command enables you to place in the drawing a new instance of an existing plate position. Upon activating this command, the dialog box of the following layout will open up:

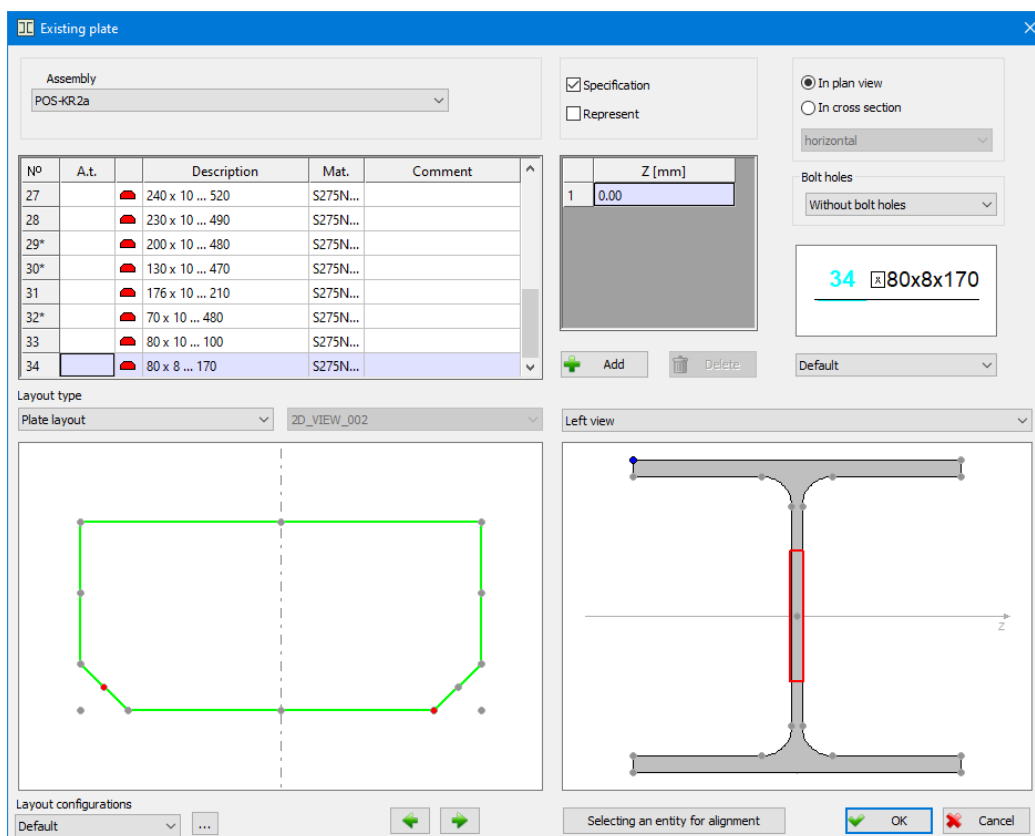

Assembly The combo box for selecting the current assembly position.

Specification The check box the state of which determines whether a plate will be included in the specification or not.

Represent When this check box is turned on, represent of chosen plate position is being placed in the drawing. Represent is plan view of the plate, whose geometry may differ from the plate position geometry. Only the thickness of both plate position and its represent must be the same. Since represent is not a material

entity, upon its placement in the dialog box, all the options for alignment by depth (in the Z-axis direction) are unavailable. Plate represent may be placed in both plan view and in cross section.

In plan view- When this switch is turned on, plate represent in plan view is being placed in the drawing. Geometry of plate represent in plan view is assigned upon exiting the dialog box, by drawing an arbitrary polyline or by choosing one of available options from the command bar. When mouse pointer is placed above the left drawing in the dialog box, a drop-down menu for choosing how represent is displayed in the drawing will open up upon pressing the right mouse button: 'Drawing the line as visible' and 'Drawing the line as invisible'. Chosen option from the menu will be applied in case of all segments of the represent contour, and settings in more detail can be performed additionally, in the dialog box for plate represent editing.

In cross section – When this switch is turned on, plate represent in cross section is being placed in the drawing. In case mouse pointer is placed above any of the plate contour segments, on the left drawing in the dialog box, it will change the color. Pressing the right mouse button will result in opening a drop-down menu for choosing how this contour segment is displayed: 'Drawing the line as visible', 'Drawing the line as invisible', 'The line is not being drawn' and 'The line is being drawn as intermission' (this option is in the menu only in case the segment representing the plate thickness is selected). Upon exiting the dialog box, the position and the length of the represent in the drawing are assigned by choosing two points.

Left table The table displays all plate positions belonging to the current assembly position. The plate position which is in the table marked with a special color is currently selected for placing. Fields in the columns 'A.t.' and 'Comment' are editable, and an additional tag i.e. an arbitrary comment for a plate position can be assigned in them.

In plan view The switch upon selecting which the instance of an existing plate seen in plan view is placed in the drawing.

In cross section The switch upon selecting which an existing plate instance seen in cross section is placed in the drawing. When this option is selected, the combo box for selecting the plate orientation ('vertical' or 'horizontal') becomes available too.

Right table Using the 'Existing plate' command enables you to place simultaneously in the drawing multiple instances of an existing plate position. All instances are displayed in this table in which the current instance is marked with a special color. Alignment by depth is performed independently for each of them, by entering the distance between the instance and the drawing plane into an appropriate field in the 'Z [mm]' column. In this table, there is also a 'Mirr.' (Mirror) column. When a plate in cross section is placed, the 'Mirr.' check box must be turned on, to get the mirrored transformation of the selected plate.



Add

The button upon activating which a new plate instance is inserted into the table.



Delete

The button upon activating which a new plate instance is removed from the table.

Bolt holes

This combo box becomes available only when at least one of the previously placed instances of the selected plate position has bolt holes. By selecting an appropriate option from the combo box, the plate can be placed in the drawing either without holes or with the same holes as any other previously placed instance.

Labeling style From the combo box, you can select any of the previously defined configurations of labeling styles. The preview which is above the combo box displays the label layout corresponding to the selected style.

Layout type The combo box which allows you to select the method of viewing the plate in the left drawing.

Left drawing If you select the 'Plate layout' option from the 'Layout type' combo box, this drawing will display what the plate will look like when it is placed in the main drawing. In all intersection points of the contour segments, in the middle of each segment, and in the apexes of plate bounding box small circles are placed. These circles indicate that any of the points can be selected as the reference point for placing the plate instance in the main drawing. Apart from this, the axis of the cross section displayed in the right drawing in the dialog box is also drawn. However, if you select options 'Elements from the current assembly' or 'All elements' from the 'Layout type' combo box, this drawing will display all elements from the current assembly i.e. all assemblies, whereas the instances of the selected plate position are marked with a special color.



Buttons upon activating which the plate orientation is changed. The plate can resume the position of any previously placed instance of the selected plate position. Also, it is possible to perform plate alignment with local axes.

Selecting the view

The combo box, which is above the right drawing, allows you to select one of the offered cross section planes, as well as its plan view.

Right drawing In this drawing, you can perform alignment by depth of the plate which is placed with the selected entity for alignment. Alignment is performed in the same way as within the 'New plate in plan view' command.

Selecting an entity for alignment

The button upon activating which taking directly from the drawing is made possible and selecting an entity for alignment.

Layout configurations

The combo box for selecting any of the previously defined configurations of entities layout.



The button upon activating which the dialog box for defining configurations of entities layout will open up. Working with this dialog box will be described in more detail within the 'Entity layout' command.

Upon exiting the dialog box, you must select the reference point from the drawing, as well as the point which will define the plate angle with respect to the horizontal.

Reference point:

Angle:

4.5 Bended plate

Using this command allows you to create a new bended plate position and place material instance perpendicular to the drawing plane in the drawing. Bended plate can be described as thin-wall shapes with an arbitrary number of segments of same thickness, created by bending the plate. Since geometry of the bended plate cross section can be quite complex, a girder is being used as a base for creating this entity. Regardless of that, it is drawn and marked as the plate.

Either by selecting the '**Bended plate**' command from the '**Metal Studio**' drop-down menu or by clicking on the icon , the command bar will obtain the following layout:

Bended plate – first point:

The floating dialog box of the same layout as in case of command for placing the new plate in cross section opens up at the same time.

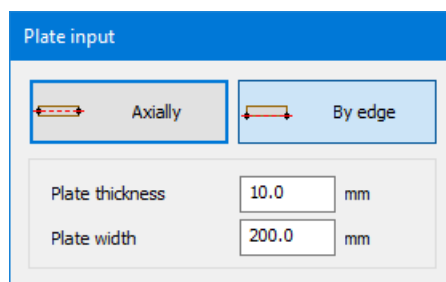

Upon choosing several points from the drawing, length and mutual relations of the bended plate cross section are assigned. Additional data needed for its creating is assigned in the floating dialog box.

Axially In case this option is turned on in the dialog box, polyline representing the bended plate cross section axis is assigned by choosing the points from the drawing.

By edge In case this option is turned on in the dialog box, polyline representing one edge of the bended plate cross section is assigned by choosing the points from the drawing. Considering that the program is not able to determine which is the edge in question, it is necessary to use the mouse for choosing the side of the polyline it is placed on:

Orientation [Back]:

Plate thickness The edit box for assigning plate thickness.

Plate width The edit box for assigning plate width.

Once you have defined the bended plate geometry, you can select from the drawing an existing girder or plate, with which it will be aligned by depth, and the command bar will obtain a new layout.

Selecting entities for alignment [Exit] <Exit>:

Selecting an entity for plate alignment can be performed subsequently from the dialog box of this command.

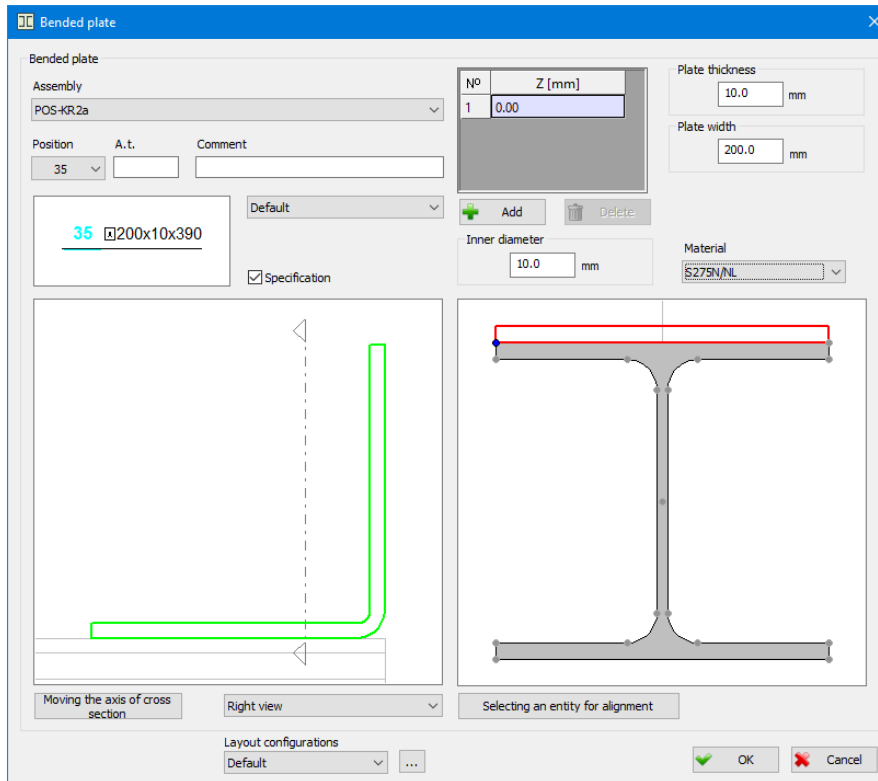

Most of the data in this dialog has the same meaning as in the dialog box of the 'New plate in plan view' command, therefore will not be explained again. New data is:

Plate width The edit box for changing the width of bended plate. Width is previously assigned in the floating dialog box.

Inner diameter The edit box for changing the inner diameter of curve between 2 segments of bended plate.

4.6 Web stiffening

Using this command allows you to easily place the web stiffening with girders of different shapes. It is done by only selecting the girder and determine the stiffening position by choosing two points. Program automatically shapes the plate in cross section, so that it corresponds to the cross section of the selected girder, and places it to the assigned position.

Either by selecting the '**Web stiffening**' command, from the '**Metal Studio**' drop-down menu or by clicking on the icon , the program will request from the command bar that you select the girder the web stiffening is going to be placed on.

Selecting girder [Exit] <Exit>:

Upon girder selection, the same floating dialog box, as in the case of command 'New plate in cross section' opens up.

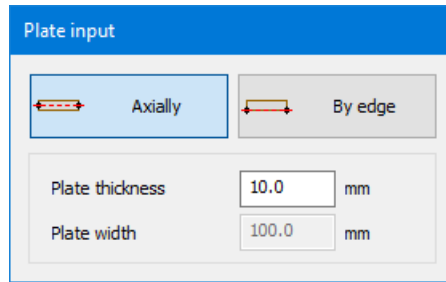

The edit box '**Plate width**' is unavailable for change, because this value is being automatically determined by the program.

At the same time, a message appears on the command bar, demanding the assignment of the first,

Plate in cross section - first point:

And right away, the second point of web stiffening.

Plate in cross section - second point [Back]:

By choosing these points, we determine the position of the web stiffening in the drawing. It is important to mention that one must be careful, while assigning these values, in relation to the plate position and its direction in the drawing. The accurate position and the final points in the direction of the plate are determined by the program, based on the girder geometry.

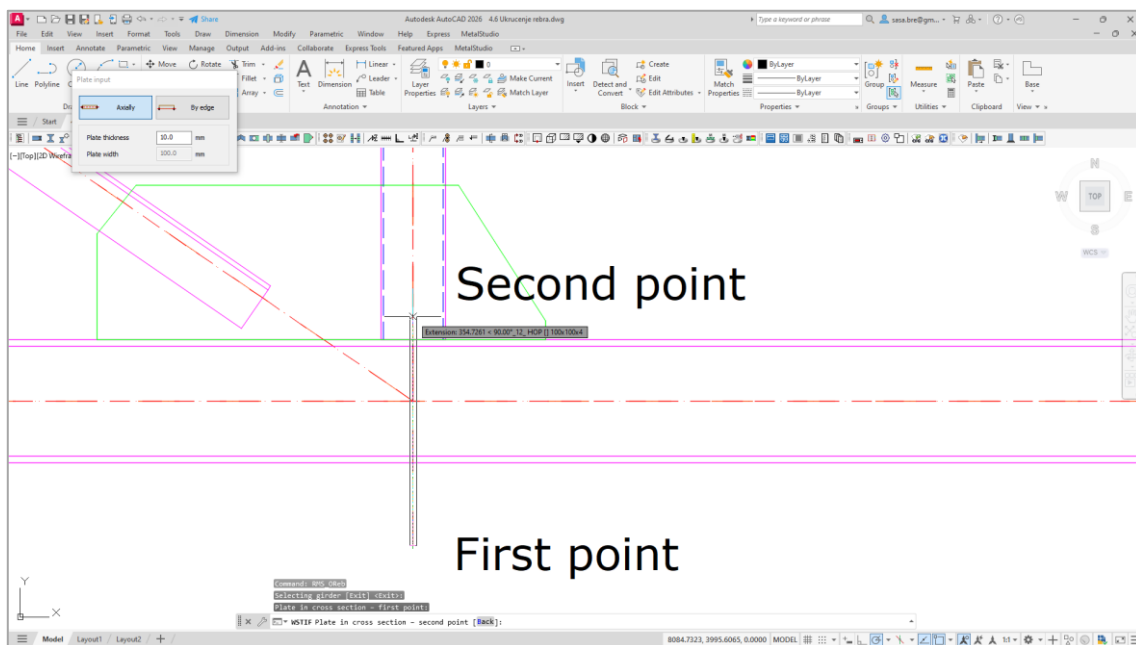

Example of assigning the first and the final point of web stiffening

Upon choosing these points, a dialog box of the following layout will open up:

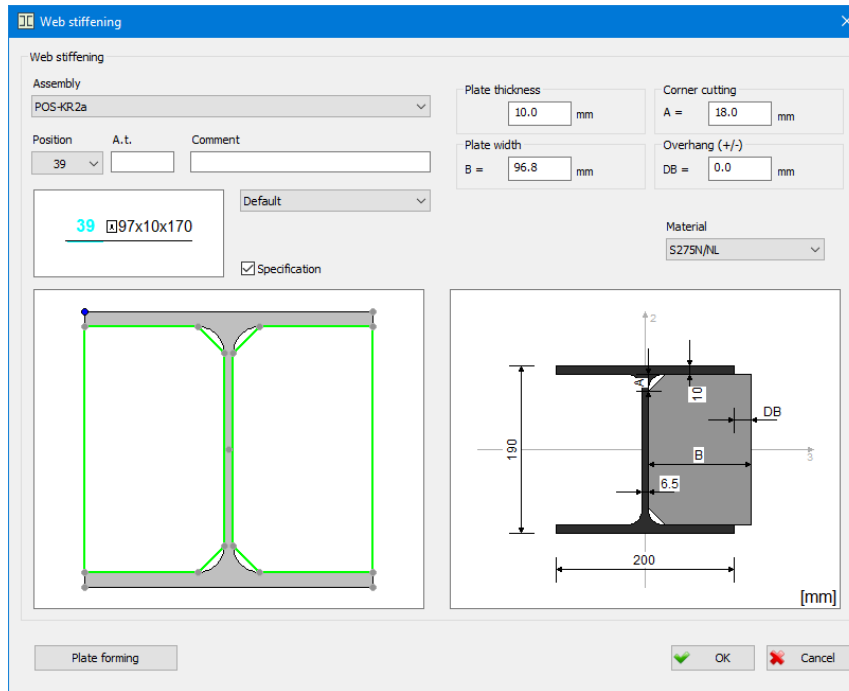

Program shapes the plate based on the geometry of the girder cross section, and displays it on the left image in the dialog box, along with the girder cross section. In all the intersection points of the plate contour segments, small circles are placed. One of these is always displayed in a different color, which means that this point is currently selected as the reference point. Changing of reference point is performed by placing the mouse pointer above one of the small circles, and when it changes the color, the left mouse button is pressed. When the mouse pointer is placed above one of the small circles, in the upper left corner of the drawing, the program will display perpendicular distances from it to the reference point.

In the right image, all the parameters that can be altered in this dialog box, and have an impact to the stiffening geometry, are schematically labeled.

Plate width B= This edit box is used to display the plate width the program assigned based on the girder cross section geometry. It can be altered by entering the new value.

Corner cutting A= The edit box where the value of the plate corner cutting assigned by the program may be altered. Detailed shaping of the plate corners may be performed in the dialog box for shaping, which opens up using the 'Plate forming' button.

Overhang (+/-) DB= If a positive value is entered in this box, it will increase the plate width for that particular value, and it will be performed by moving the edge of apexes.

We must note that, by altering any of these values, the modifications of the plate geometry that are previously assigned in the dialog box 'Plate forming' will be canceled.

Plate thickness The edit box for assigning the plate thickness.

The other parameters in the dialog box have the same meaning as in case of the previously described commands.

Upon activating the '**OK**' button, the dialog box will close, and the created girder web stiffening is being placed in the drawing.

5. FORMING GIRDERS AND PLATES

Since quite frequently there is a need to make changes on placed entities, within the **'Metal Studio ► Forming'** drop-down menu, there are a number of commands designed by the program which enable users to modify subsequently girders and plates located in the drawing. A change made to a single girder or a plate will cause changes on all instances of the given position.

5.1 Forming girder ends

Using the **'Forming girder ends'** command enables you both to extend girders and shorten them to the selected boundaries. Either by activating the command from the **'Metal Studio ► Forming'** drop-down menu or by clicking on the icon , a dialog box of the following layout will open up:

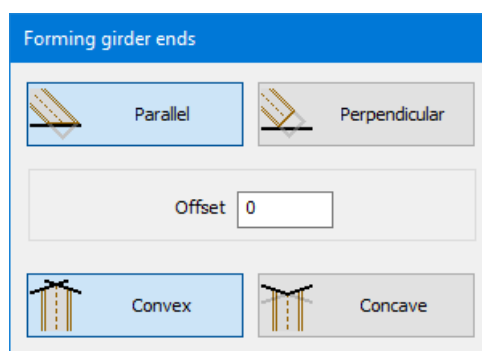

The dialog box for forming girders by assigning boundaries - the layout

This dialog box is displayed on the screen all the time the command is being executed, which means that changes can be made in it even after assigning boundaries and selecting girders.

Offset The edit box for entering the value by which the selected girders will be extended i.e. shortened in relation to the assigned boundaries. If a positive value is entered, the selected girders will be extended for the given value, whereas if a negative value is entered, the selected girders will be shortened for the given value. However, if a zero is assigned, girders ends will, upon the execution of the command, be placed exactly in the selected boundaries.

Parallel The ends of the selected girders will be formed so that they will be either extended or shortened for the value assigned in the 'Offset' edit box parallel with the selected boundaries.

Perpendicular The ends of the selected girders will be formed so that the value assigned in the 'Offset' edit box will represent the perpendicular distance from the assigned limit to the nearest point of the selected girder.

Convex This button becomes active only when the 'Parallel' button is on, and it indicates that the ends of the selected girders will have a convex shape parallel with the selected boundaries. Obviously, this button makes sense only if multiple boundaries have been selected.

Concave This button becomes active only when the 'Parallel' button is on, and it indicates that the ends of the selected girders will have a concave shape parallel with the selected boundaries. Obviously, this button makes sense only if multiple boundaries have been selected.

Upon the appearance of the dialog box, the command bar obtains the following layout:

Select boundaries [Exit] < Exit >:

Select boundaries

The selection procedure is the standard one. As for the boundaries, it is possible to select any straight lines from girders, plates and their views, as well as the AutoCAD lines to which you want to extend or shorten girders. It is important to emphasize here that girders can be extended only to the boundaries with which the intersection point can be obtained after the girder has been extended, whereas shortening girders can be carried out only for the boundaries which intersect the girder.

Once you have selected all boundaries, the program will request from the command bar that, in the select-box, you capture the end of the girder you want to extend or shorten:

Select the girder end which to be modified [Exit] < Exit >:

Select the girder end which to be modified

You must select the girder end which you want to extend or shorten to the previously selected boundaries. Also, it is possible to select arch girders for forming. The program will constantly request from the command bar that you keep selecting new girder ends until you select the 'Exit' sub-option from the command bar.

5.2 Assigning the girder cutting plane

Using the '**Assigning the girder cutting plane**' command enables you to shorten the girder to the assigned plane. Either by activating the command from the '**Metal Studio ► Forming**' drop-down menu or by clicking on the icon , the command bar obtains the following layout:

Selecting girder:

You are now requested to select the girder you want to shorten. Also, it is possible to select arch girders for forming.

After selecting, the message will appear on the command bar in which you are requested to assign the girder cutting plane which is defined with two points:

First point:

End point:

During assigning points, it is necessary that they form a plane which intersects the selected girder.

Point on the side you want to keep:

Since the assigned cutting plane splits the girder into two parts, it is necessary that you assign a point on the girder side you want to keep, upon which the command will end and the girder will be shortened by the given plane.

5.3 Forming a joint at an angle of two girders

Using the '**Inclined joint of two girders**' command enables you to form two girders that create different angles with respect to the horizontal, and whose axes have mutual apex. Forming is performed so that the ends of girders are parallel with the angle bisector between their axes, with the possibility of assigning the distances for placing the endplate, which will be used for their joining. Either by activating the command from the '**Metal Studio ► Forming**' drop-down menu or by clicking on the icon , a floating box for entering the distances opens up, and from the command bar, you are demanded to select the first girder.

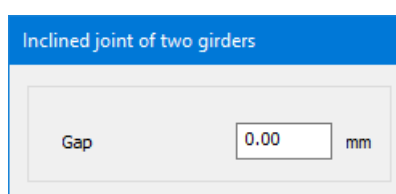

Gap The edit box for assigning the distance between girders.

Selecting the first girder [Exit] < Exit >:

After selecting the first girder, it is necessary to select the second one:

Selecting the second girder [Exit] < Exit >:

Upon finished selection of the second girder, they are being formed.

This command has a circular character, so the program will again demand, from the command bar, the selection of the first girder, until the sub-option '**Exit**' is chosen.

5.4 Assigning a hole in a girder or plate

Either activating the '**Defining an opening**' command from the '**Metal Studio ► Forming**' drop-down menu or clicking on the icon  will result in starting the procedure of selecting an entity on which a hole is assigned:

Selecting girder or plate:

Upon selecting the girder or the plate, you can start the procedure of defining an arbitrary polyline which will determine the geometry of the opening to be placed.

First point: [Rectangle/Circle]:

The procedure of defining the polyline which determines the opening contour geometry is the same as when plate geometry is created.

Rectangle Drawing openings of a rectangular shape.

Circle Drawing openings of a circular shape.

If you have assigned the hole contour on the plate, upon closing it, the command will end and the hole will be drawn on the plate. However, if you have assigned the hole contour on the girder, upon closing it, the program will automatically open the dialog box for defining the hole depth:

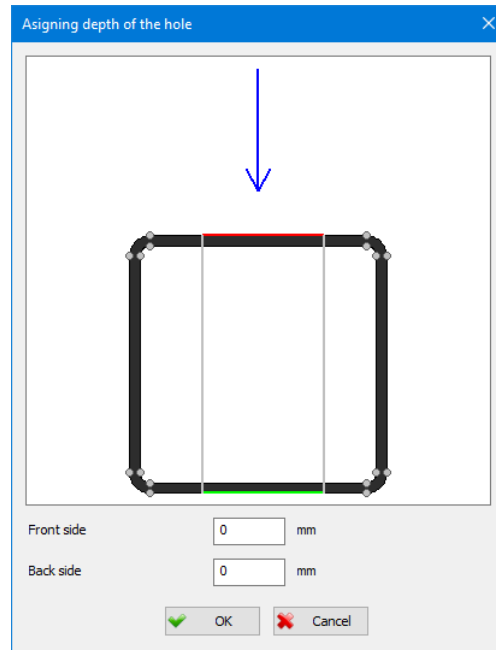

The dialog box for defining the hole depth

The drawing in the dialog box displays the girder cross section and illustrates how the hole is drilling the cross section, while the blue arrow indicates the direction by which the hole is spreading in depth.

Front side The edit box for entering the value by which the hole depth will be reduced from the front side, i.e. from the side which is closer to the viewing plane. Since this change is instantly visible in the drawing in the dialog box, the user is allowed to adjust easily the depth of hole penetration through the section.

Back side The edit box for entering the value by which the hole depth will be reduced from the back side. Since this change is instantly visible in the drawing in the dialog box, the user is allowed to adjust easily the depth of hole penetration through the section.

The hole depth can be adjusted in the very drawing, in the dialog box. One side of the hole is always marked in red color, which means it is selected for moving. Upon opening the dialog box, it is the front side (side closer to the blue arrow), while the back side is marked in green color. When the mouse pointer is placed above the side marked in green, and the button is pressed, that very side turns red, i.e. selected for moving. Moving itself is very simple: mouse pointer must be placed to desired spot in the drawing, and the left button pressed. The depth alteration is immediately seen in the drawing, and the value it is changed for is displayed in the appropriate edit box, 'Front side', i. e. 'Back side'. To allow more precise selection of the points from the drawing, little circles are placed in all the intersection points of contour of the girder cross section. When the mouse pointer is placed above any of these circles, it will change the color, and the selected side of the hole is moved to that very point by pressing the left button.

Upon activating the '**OK**' button, the dialog box will close, and program creates assigned hole in girder, with depth defined in this dialog box.

5.5 Subtraction at the place of penetration with another entity

Since quite frequently in practice there are cases when one entity penetrates through another, the program has envisaged the possibility to subtract (at the place of penetration) the part through which the other entity penetrates. Either by activating the '**Subtraction at penetration area**' command from the '**Metal Studio ► Forming**' drop-down menu or by clicking on the icon , the command bar obtains the following layout:

Select entities which will be modified by subtraction:

You are now requested to select all entities from which you want to subtract parts through which other entities are penetrating, where both plates and girders can be selected. Right-clicking will mark the end of the selection process, and the command bar will obtain a new layout:

Selection of subtraction entities:

You are now requested to select all entities which are going through the previously selected entities, and again, both plates and girders can be selected. The command will end by either right-clicking or pressing the Enter key.

5.6 Girder dividing

Either by selecting the '**Girder dividing**' command from the '**Metal Studio ► Forming**' drop-down menu, or by clicking on the icon , the division of the selected girder into several girders, creating new positions is enabled. Activating this command results in the standard selection procedure:

Select a girder to divide [Exit] <Exit>:

Afterwards, enter the points for the division of the girder:

Input a breakpoint [End] <End>:

Once the first split point is selected, the program will continue to ask you to set a new point, until you select the '**End**' sub-option to indicate that all desired points have been set.

After selecting the split points, the command line takes on a new form:

Offset <0>:

The user is now required to specify the distance between the girders at the selected split points. In square brackets is shown the value of the space that was set when the command was previously called. By activating the right mouse button or selecting the 'Enter' key without entering a new space value, the offered value will be retained.

5.7 Editing formings

Using the '**Editing formings**' command which is contained within the '**Metal Studio ► Forming**' drop-down menu enables you to have an overview of and delete all previously assigned formings on the selected entity, i.e. a girder or a plate. Activating this command will result in starting the standard procedure of selecting:

Selecting entities for deleting holes, boundaries and series [Exit] < Exit >:

The way this command operates is exactly the same regardless of whether the selected element is a girder or a plate. Upon selecting the entity, the following dialog box opens up:

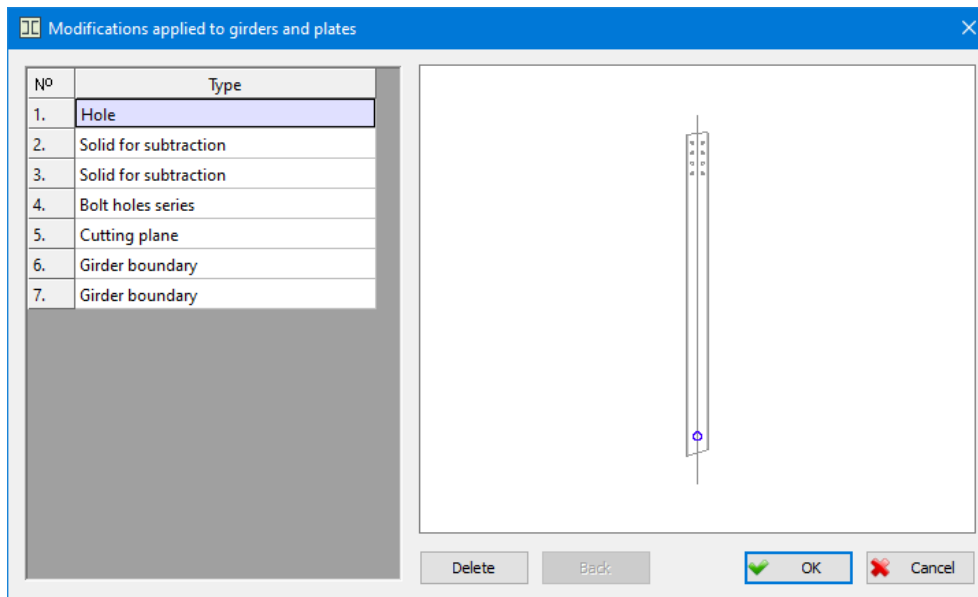

The dialog box for deleting the assigned formings on the selected entity

The left part of the dialog box displays a list containing all formings on the selected entity, whereas the right part of the dialog box displays the entity with all formings. The currently selected forming is clearly indicated.

- Nº** The column with (ordinal) numbers of all formings on the selected entity.
- Type** The column with types of formings on the selected entity. Five types of formings can be located on a single entity:
- Hole** – formings on an entity created by drilling a hole.
 - Solid for subtraction** – formings on an entity created via the 'Subtraction at penetration area' command.
 - Bolt holes series** - formings on an entity created via the 'Bolt series' command.
 - Cutting plane** - formings on girders ends created via the 'Assigning the girder cutting plane' command.
 - Girder boundary** - formings on an entity created via the 'Forming girder ends' command.

- Delete** The button upon activating which you are able to remove from an entity the forming which is currently selected in the list. Every single deletion also causes removing the forming from the drawing in the dialog box, so the user can have an overview of other formings that are left.
- Back** The button upon activating which you are able to bring back into the drawing the entity forming which was last deleted.

Activating the '**OK**' button will indicate the acceptance of all actions performed in the dialog box and the program will modify the drawing so that it completely corresponds to all the changes made. The '**Cancel**' button is intended for quitting.

5.8 Alteration of the plate contour

One of the methods for additional alteration of the plate geometry in plan view is the stretching of the grips, placed in all refraction points of the plate contour by the program, upon its selection in the drawing. Since these grips are usually not sufficient for achieving the desired geometry, selecting the '**Alteration of the plate contour**' command enables you to place a new 'grip-point' in the arbitrary point you select on the plate contour. Apart from enabling the placement of the new grips, it enables the removal of the current grips. Either by selecting this command from the '**Metal Studio ► Forming**' drop-down menu or by clicking on the icon , a message appears in the command bar, demanding the user to chose one of the two options provided.

Alteration of the plate contour. Chose the operation type [Add/Delete]:

Add Selecting this option results in entering the procedure of adding a 'grip-point', where a message appears in the command bar, demanding the user to chose the desired point from the contour.

Chose the point [End] <End> :

After selecting the first point, the program will still request that you set the new point, until you select the '**End**' sub-option and terminate this command. In all selected points from the plate contour, the program places new 'grips', and you can now easily change the plate geometry by stretching them.

Delete Selecting this option results in program demanding the user to select one of the marked points from the plate contour. The program removes these selected points from the drawing, and modifies the plate contour by joining the two adjacent 'grip-points'.

Chose the point [End] <End> :

After modifying, the program will still request that you select the point from the command bar, until you select the '**End**' sub-option and terminate this command.

6. CONNECTING DEVICES

6.1 Bolt series

Using this command enables you to create the connection between the selected entities by placing a bolt series according to the assigned parameters. These bolts automatically drill holes through the entities they connect, but drilling holes without placing bolts is also possible.

Either by activating the command from the **'Metal Studio ► Connecting devices'** drop-down menu or by clicking on the icon , the program will request from the command bar that you select the entity for connecting.

Selecting objects:

You are now requested to select the reference point for placing a bolt series:

Reference point:

When the reference point is selected, the dialog box for assigning all parameters required for creating bolt series will open up.

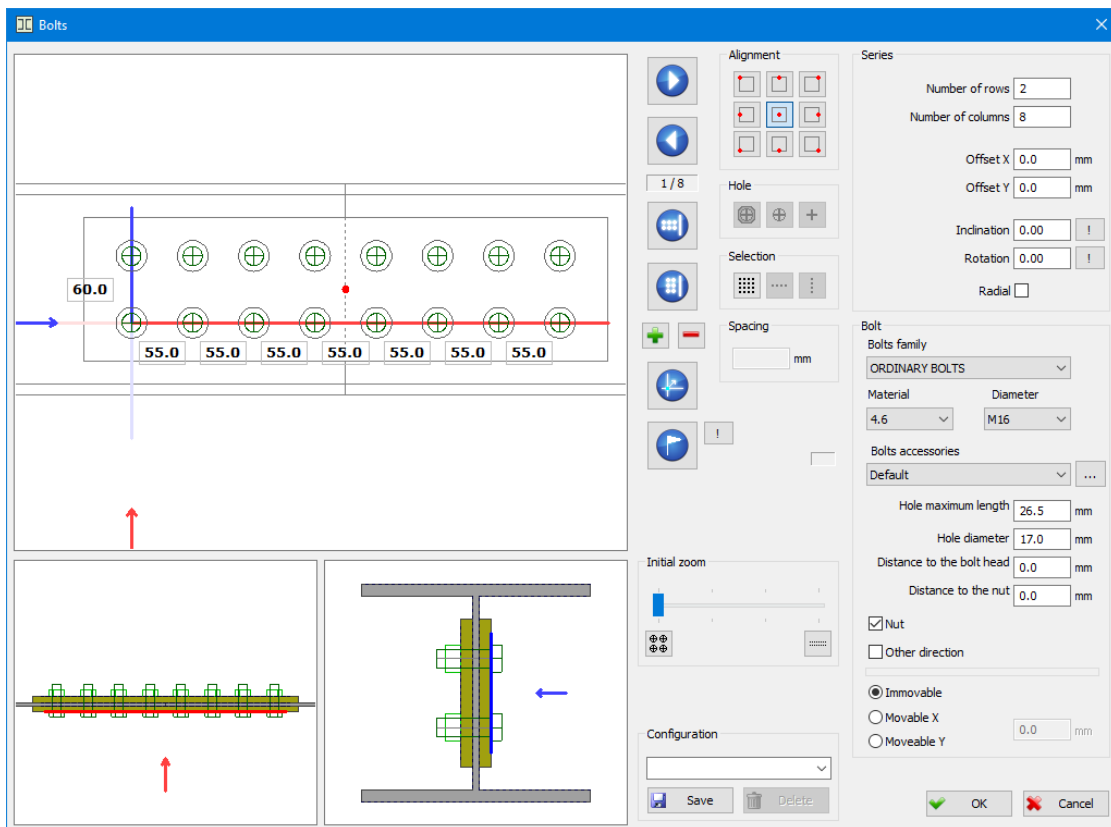

The drawing in the upper part of the dialog box displays the layout of the series which is being created according to the current state of parameters. The selected reference point is marked in red, whereas special colors are used to draw the axes of longitudinal and cross sections which are displayed in the two drawings in the lower part of the dialog box. The displayed arrows indicate the side from which the section plane is viewed.

The plane in which the bolt heads and one of the selected entities are touching is called the series plane, and the given entity is the series leader. From this it follows that, all subsequent actions performed on this entity, such as moving or copying, apply also to the bolt series whose leader it represents. In the section drawings, the series plane is marked with a special color. You can change the series plane by selecting a new plane from the section drawing. Changing it is performed by placing the mouse pointer over another plane and by pressing the left mouse button when it changes its color.



The buttons upon activating which the series plane is changed. Whenever the first button is clicked, some other plane will be placed for the series plane until all possible planes have had their turn. Clicking the second button also enables changing the section planes but in the reverse order. In the field below these buttons, the program writes the total number of possible planes, as well as the number of the current plane.

Alignment

The switches upon activating which the series area is aligned with the selected reference point.



Upon opening the dialog box, the program specifies the bolt series direction based on the entities which have been selected for connecting. The series default direction can be changed via this button so that it is perpendicular on the segment which has been selected from one of the selected entities contour. Selecting a segment is performed from the drawing in the upper part of the dialog box, by placing the mouse pointer over the desired segment and by pressing the left mouse button after switching this button.



The series default direction can be changed via this button so that it is parallel with the segment which has been selected from one of the selected entities contour.



The button upon activating which taking directly from the drawing is made possible in order to select entities which are added to the previously selected entities for connecting with the bolt series.



The button upon activating which taking directly from the drawing is made possible in order to select entities which are discarded from selection for connecting with the bolt series. We should warn you that the series leader cannot be discarded from selection.



The button for selecting the point through which the axes of cross section will go. The axes of cross section must go through one of the bolts from the drawing in the upper part of the dialog box. Selecting the bolt is performed first by clicking this button and then by placing the mouse pointer over the desired bolt and pressing the left mouse button when it changes its color.



The button for changing the reference point. When this button is clicked, all points which can be selected as the reference point are marked in the drawing in the upper part of the dialog box. Selecting the new reference point is performed by clicking on any point. Beside this button, there is another button,  upon activating which taking directly from the drawing is made possible in order to select a new reference point.

Selecting bolts from the drawing in the dialog box

Selecting the bolt is performed first by placing the mouse pointer over the desired bolt and pressing the left mouse button when it changes its color. New bolts are included in the selection in the same way, when the Shift key is pressed. Discarding individually all previously selected bolts from the selection is performed in the same way, whereas deselecting all bolts is performed by clicking on any empty part of this drawing.

Selection:



Selecting all bolts from the series.



This button becomes available only when at least one bolt has been selected. Also, selecting all other bolts from the row in the series to which the given bolt belongs is performed via this button.



This button becomes available only when at least one bolt has been selected. Also, selecting all other bolts from the column in the series to which the given bolt belongs is performed via this button.

Hole

The buttons which are located in this part of the dialog box work as switches. One of these switches must be turned on for each bolt from the series. The switch also defines the way in which the given bolt will be placed in the drawing.



Both bolts and holes are placed in the drawing.



Only holes are placed in the drawing.



Neither bolts nor holes are placed in the drawing.

Spacing

The edit box for assigning the spacing between rows and columns in a series. In the drawing in the dialog box, there are small rectangles, between all rows and columns, in which the spacing between adjacent rows i.e. columns is written. Upon clicking on any of these rectangles, it is marked with a special color, whereas the value which is displayed in it is written in the edit box 'Spacing'. The spacing between rows i.e. columns between which the selected rectangles are located is changed by entering a new value in the edit box. Including new rectangles in the selection as well as discarding the previously selected ones is performed by clicking on them while holding down the Shift. By double-clicking on any of these rectangles, depending on the place where it is located, all spacings between rows i.e. columns in the series are selected. The same value can be assigned to all selected spacings by entering in the 'Spacing' edit box.

Series:**Number of rows**

The edit box for assigning the bolt series number of rows. If a radial series is created, the series 'Number of rows' is assigned in this field.

Number of columns

The edit box for assigning the bolt series number of columns. If a radial series is created, the series 'Number of circles' is assigned in this field.

Offset X Series offset in the X direction.

Offset Y Series offset in the Y direction.

Inclination The angle which the series columns form with the Y direction. It can also be assigned by selecting points from the drawing via the  button. If the radial series is created, this edit box becomes unavailable.

Rotation The angle of the series rotation around the reference point. It can also be assigned by selecting points from the drawing via the  button.

Radial By turning this check box on, the radial bolt series is created.

Bolt:

Bolts family You can set one of the bolt families contained in the database of bolts as the current one by selecting from this list.

Diameter The list from which bolt diameter is selected.

Material The list from which bolt material is selected.

Bolts accessories

Any previously saved bolts accessories configuration can be selected from the list to represent the current one.



The button opening the dialog box for determination of the bolts accessories configuration. Within the bolt accessories it is possible to define flat and inclined washers (next to the head and next to the nut), and the safety nut that will be drawn during the setting of bolt series.

	Hole diameter	Outer dimension	Thickness	Round	Description
Washer under the head	12.00	18.00	2.00	<input type="checkbox"/>	
Taperd washer under the head	12.00	16.00	1.00	<input checked="" type="checkbox"/>	
Taperd washer under the nut	12.00	20.00	2.00	<input type="checkbox"/>	
Washer under the nut	12.00	24.00	2.00	<input checked="" type="checkbox"/>	
Safety nut		16.00	6.00	<input type="checkbox"/>	
<input type="checkbox"/> Aligned					

Washer under the head

Enabled check box indicates that bolts with the washer next to the head are being placed on the drawing.

Taperd washer under the head

Enabled check box indicates that bolts with the washer of variable thickness next to the head are being placed on the drawing.

Taperd washer under the nut

Enabled check box indicates that bolts with the washer of variable thickness next to the nut are being placed on the drawing.

Washer under the nut

Enabled check box indicates that bolts with the washer next to the nut are being placed on the drawing.

Safety nut

Enabled check box indicates that bolts with the safety nut are being placed in the drawing.

Aligned This check box is only available when the safety nut is installed. When it is on, the sides of the nut and the locknut are aligned, so that in the cross-section drawing, the bolt looks like it is folded over, as shown in the picture:

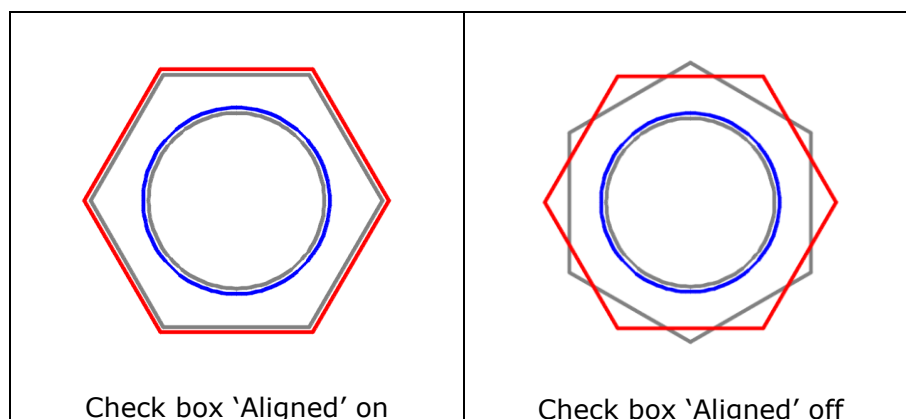

All the washers and the safety nut are defined by their description and multiple numerical data assigned in appropriate edit boxes:

Hole diameter

The edit boxes for assigning the diameter of the hole for each of the washers. The hole diameter must be larger or equal to diameter of the bolt body, otherwise, the program will issue an appropriate warning, upon exiting the dialog box. Hole diameter of the safety nut is equal to the nut diameter, and in such way is assigned.

Outer dimension

The edit boxes for assigning the outer dimension for each of the washers and the safety nut. Outer dimension must be larger than the hole diameter, otherwise, the program will issue an appropriate warning, upon exiting the dialog box.

Thickness The edit box for assigning the thickness for each of the washers and the safety nut.

Round When this check box is on, the washer in the drawing will be circular.

Description

The edit box for assigning the description of each of the washers and the safety nut. In case the user does not enter the description, program will automatically generate the name including their dimensions, upon creating the report for the recapitulation of the nuts and the washers.

Configuration

Any previously saved configuration can be selected from the list to represent the current one. Default configuration is the configuration with all the check boxes disabled, and in case of this configuration, the bolts are drawn without the washers and the safety nut.

 **Save** The configuration with the current state of parameters in the dialog box is saved in the database.

 **Delete** Deleting the current configuration from the database.

Hole maximum length

The edit box for assigning the maximum width of the elements which are being connected. If the assigned value is greater than the real width of the elements which are being connected, the program will place bolts according to the real width. If the assigned value is less than the real width, the program will issue an appropriate warning message upon exiting the dialog box. This value can also be assigned by selecting a point from the drawing of either the cross or longitudinal section in the dialog box. To do this, position the mouse pointer over the desired spot and press the right mouse button. The distance between the assigned point and the series plane will be displayed in this edit box. If the mouse pointer is positioned over a plane belonging to one of the elements which are being connected, it will change its color. In other words, by pressing the right mouse button, the distance between the given plane and the series plane will be written in the edit box.

Hole diameter The edit box for assigning the diameter of the hole drilled by the bolt in entities which are being connected. The default value depends upon the selected family and the bolt diameter. The program will import this value from the database of bolts.

Distance to the bolt head

The edit box for assigning the distance from the bolt head to the series plane. This data is useful for placing anchors and practically it represents part of the anchor which is located in concrete.

Distance to the nut

Edit box in which the distance from the nut to the nearest entity (girder or plate) previously selected for connecting with a series of screws is set.

Nut

The check box the state of which determines whether nuts will be placed on bolts.

Other direction

Changing the bolt direction while keeping the series plane.

Immovable

Immovable bolts i.e. bolts with circular hole are placed.

Movable X

Bolts which are movable in the X direction are placed. The hole length is assigned in the edit box located on the right of this switch.

Movable Y

Bolts which are movable in the Y direction are placed. The hole length is assigned in the edit box located on the right of this switch.

Initial zoom

The starting zoom of the series drawing - the layout of the series after zoom all - is adjusted by using sliders (Ctrl+middle mouse button).



Maximal-zoomed bolt series is set for the starting layout.



Minimal-zoomed series layout enabled by this command is set for the starting layout.

Configuration:

Any previously saved configuration can be selected from the list to represent the current one.



Save

The configuration with the current state of parameters in the dialog box is saved in the database.



Delete

Deleting the current configuration from the database.

6.2 New weld - label

Using this command enables you to place in the drawing the label which indicates that a weld of the assigned characteristics is located somewhere in the structure. Either by activating the '**New weld - label**' command from the '**Metal Studio ► Connecting devices**' drop-down menu or by clicking on the icon , a dialog box of the following layout will open up:

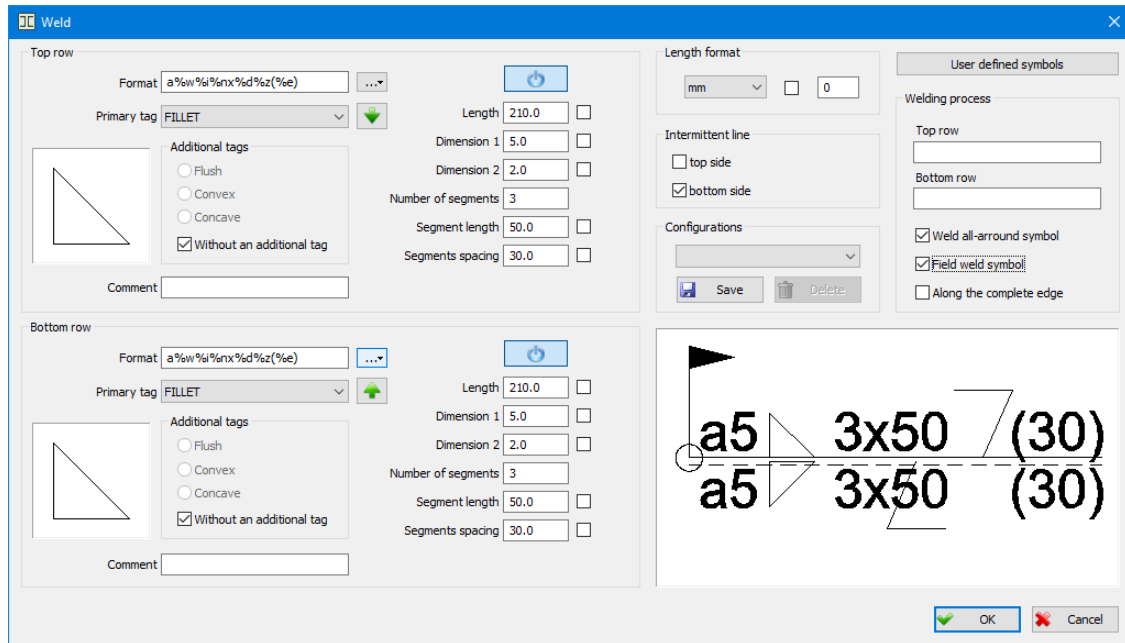

Top row

This part of the dialog box contains parameters which are used for defining the layout and the contents of the weld label above the label baseline.



The check box the state of which determines whether the weld label contents above the label baseline will be displayed in the drawing.

Format

The edit box for defining the weld label contents above the label baseline. Clicking the  button, which is in the continuation of the edit box, will result in opening the drop-down menu for selecting the parameters to be displayed in the weld label. A short description which clearly indicates what the given parameter represents in the label is written in the continuation of each parameter symbol. Selecting the desired parameter is performed simply by clicking upon which the program will close the drop-down menu and the selected parameter will be placed in the edit box. You can also assign all these parameters directly in the edit box, by entering their symbol using the keyboard. Also, you can use the keyboard to enter an arbitrary text in the edit box. This program option is mostly used for describing specific data in the label text.

Primary tag

From this combo box, you can choose the name of the weld basic tag which will be displayed in the label. Weld basic tag symbols are created in the same way as the AutoCAD blocks and are saved in the 'SymWeld.dwg' database of configurations. Working with weld basic tag symbols and the AutoCAD blocks has been described in the chapter 'Symbols used in the program'.

Additional tags

Additional tags are used for displaying more precisely the weld shape:

- Flush** The weld surface is flush.
- Convex** The weld surface is convex.
- Concave** The weld surface is concave.
- Without an additional tag** There is no need for placing an additional tag.

Comment

The edit box for entering an arbitrary comment which will be displayed in the label.

Length Weld length. If the check box which is next to this edit box is on, units will be written after the assigned value in the label.

Dimension 1 This edit box has been intended for entering the weld dimension related to the cross section. This dimension can have different meaning for different types of welds. If the check box which is next to this edit box is turned on, units will be written after the assigned value in the label.

Dimension 2 This edit box has the same purpose as the previously described one, 'Dimension 1'.

Number of segments

The number of segments is assigned in this edit box when an intermittent weld is placed. If the check box which is next to this edit box is on, units will be written after the assigned value in the label.

Segment length

When an intermittent weld is placed, the segment length is assigned in this edit box. If the check box which is next to this edit box is on, units will be written after the assigned value in the label.

Segments spacing

When an intermittent weld is placed, the spacing between adjacent segments is assigned in this edit box. If the check box which is next to this edit box is on, units will be written after the assigned value in the label.



Upon clicking this button, values which have been assigned for the parameters of the label above the label baseline are automatically allocated to the same-named parameters of the label below the label baseline.

Bottom row This part of the dialog box contains parameters which are used for defining the layout and the contents of the weld label below the label baseline. They have the same purpose as the previously described parameters of the label above the label baseline.

Intermittent line

Using the '**top side**' and '**bottom side**' check boxes enable you to place an intermittent line above i.e. below a continuous label baseline. This line indicates whether the weld front is on the side of the arrow or on the opposite side. If both check boxes are off, the intermittent line is omitted.

Welding process:

Top row The edit box in which you can assign the welding process. In the label, the welding process is written between two branches of the fork placed automatically by the program.

Bottom row Different welding processes can be assigned for both sides by entering a new value in the edit box.

Weld all-around symbol

When this check box is on, a symbol (circle) indicating that the weld is placed along a closed contour (for example, along all plate edges) is placed at the label beginning.

Field weld symbol

When this check box is on, a symbol (flag) indicating the field weld is placed at the label beginning.

Along the complete edge

This check box is active solely in case the fillet weld is selected. Upon enabling it, a symbol of a crossed triangle is drawn on the label, indicating the angular weld welded along the complete edge.

Length format From this combo box, you can select the units which are used for defining the label. Whenever units are changed, all values which have already been assigned are converted into new units. Displaying the selected units in the label is adjusted individually for each dimension by using appropriate check boxes. The check box which is located in this part of the dialog box is used for turning them on i.e. off simultaneously. The number of decimal places with which weld dimensions will be displayed in the label is assigned in the displayed edit box.

Configurations:

Any previously saved configuration can be selected from the list to represent the current one.

 **Save**

The configuration with the current state of parameters in the dialog box is saved in the database.



 **Delete**

Deleting the current configuration from the database.

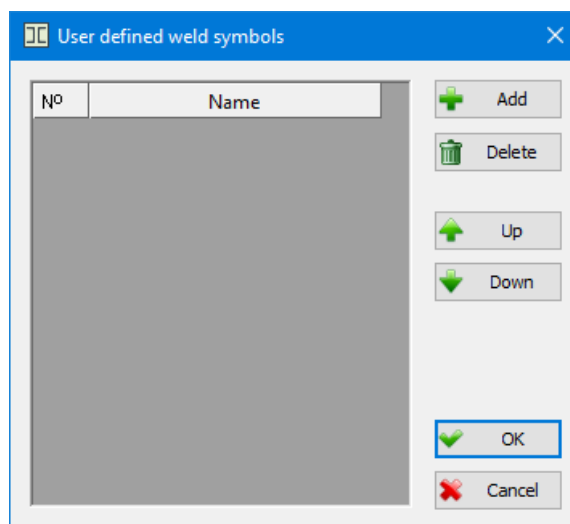
Weld tags created by users are not displayed in the list for the automatic selection, which is why they must be inserted in the list. For that purpose the '**User defined symbols**' button has been intended. Upon clicking this button, the dialog box of the following layout will open up:



To insert a weld tag, you must first add a new row in the table via the ' **Add**' button and then enter its name in the '**Name**' column.

The selected row is deleted from the table via the ' **Delete**' button, whereas using the ' **Up**' and ' **Down**' buttons enable moving one place upwards i.e. downwards.

Clicking the '**OK**' button in the main dialog box of the command will result in closing it, and the program will request from the command bar that you enter the label start point.

Label start point [Set]:

You can open the same dialog box via the **'Set'** option if you need to change certain parameters. Upon entering the label start point, the program will request that you specify the position of the label text by clicking.

Text position [Additional]:

Upon selecting the **'Additional'** option, you will start the procedure of placing an arbitrary number of additional label arrows, so that, by using a single label, you can mark the position of several identical welds in the drawing.

Label additional point [Exit] <Exit>:

Finally, the program will request that you specify the angle of the text inclination in the label either by selecting a point from the drawing or by entering a numerical value using the keyboard.

Text angle:

Upon this, the created weld label is placed on the drawing.

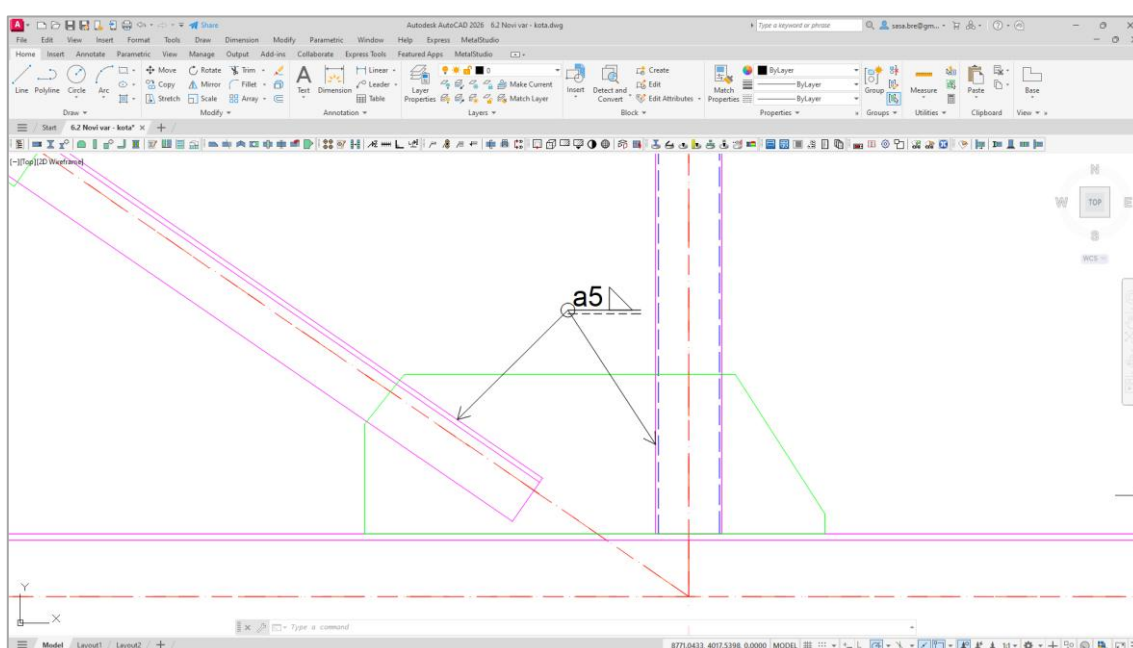

6.3 New weld – symbol in plan view

Using this command enables the placement of the weld symbol in plan view. Either by selecting the **'New weld – symbol in plan view'** command from the **'Metal Studio ► Connecting devices'** drop-down menu, or by clicking on the icon , the following dialog box will open up:

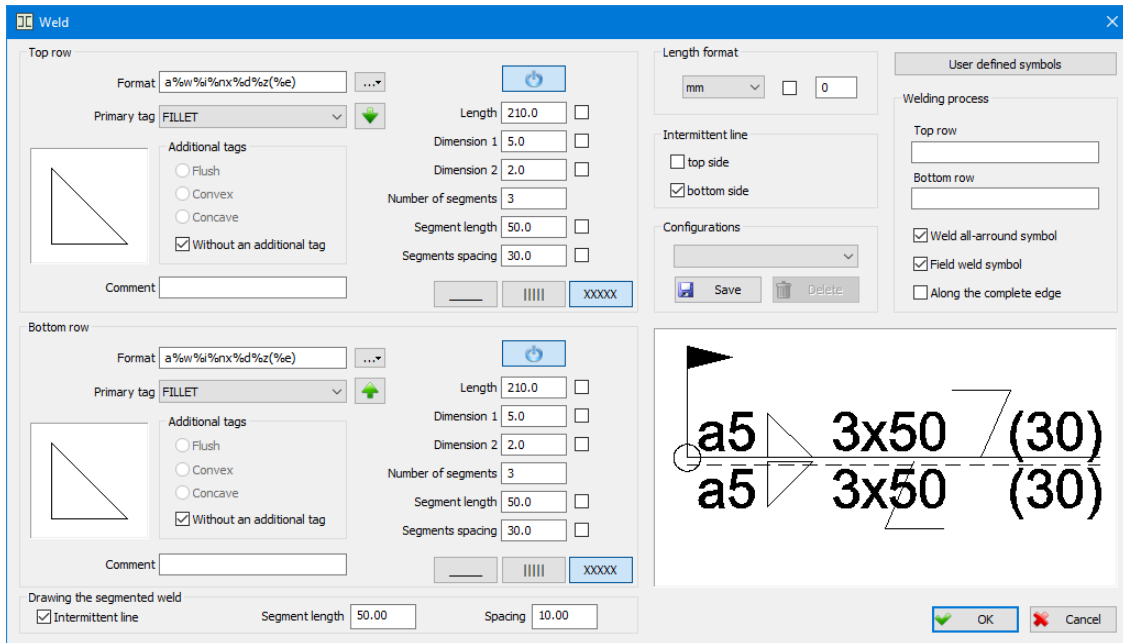

Dialog box for defining the characteristics of the weld in plan view

Working within this dialog box is the same as working within the dialog box for defining the weld label, and therefore will not be explained again (see Chapter 6.2).

The method of representing the weld in plan view, i.e. its symbol in the drawing, is defined via three buttons:

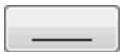

The button defining the symbol the weld will have in plan view, upon placing on the drawing.



The button defining the symbol the weld will have in plan view, upon placing on the drawing.

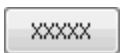

The button defining the symbol the weld will have in plan view, upon placing on the drawing.

Drawing the segmented weld:

Intermittent line

When this check box is turned on, weld symbol is being drawn in several segments.

Segment length

Maximum segment length of weld symbol. It is applied in case the check box 'Intermittent line' is turned on.

Spacing

Length of spacing between the weld symbol segments. It is applied in case the check box 'Intermittent line' is turned on.

By activating the '**OK**' button, user enters a new procedure for placing the weld symbol in plan view, with all the dialog box data attached, with the command bar obtaining the following layout:

First point (detached input) [Polyline/Rectangle/Circle/Continuous input/End] <End>:

Detached input

By activating this method of drawing, it is possible to draw several welds in plan view, not necessarily mutually connected, so that the beginning of the next weld does not necessarily have to be in the end point of the previously drawn weld.

Continuous input

By activating this method of drawing, each of the welds in plan view are mutually connected, and the drawing is performed so that the end point of the previously drawn weld is the beginning of the next weld, which is actually drawing of a polyline.

Polyline

Weld geometry in plan view is defined by selecting the arbitrary polyline from the drawing.

Rectangle

Drawing welds of a rectangle shape in plan view.

Circle

Drawing welds of a circular shape in plan view.

If you decided to define the weld geometry by drawing an arbitrary line, after the selection of the first point, a new message will appear on the command bar:

Next point [Arch/ Back]:

Arch

Drawing arch welds in plan view.

Back

Serves for canceling the selection of the first point.

Choosing the 'End' sub-option, the command is terminated, and the data provided in the dialog box will be assigned to each of the drawn welds.

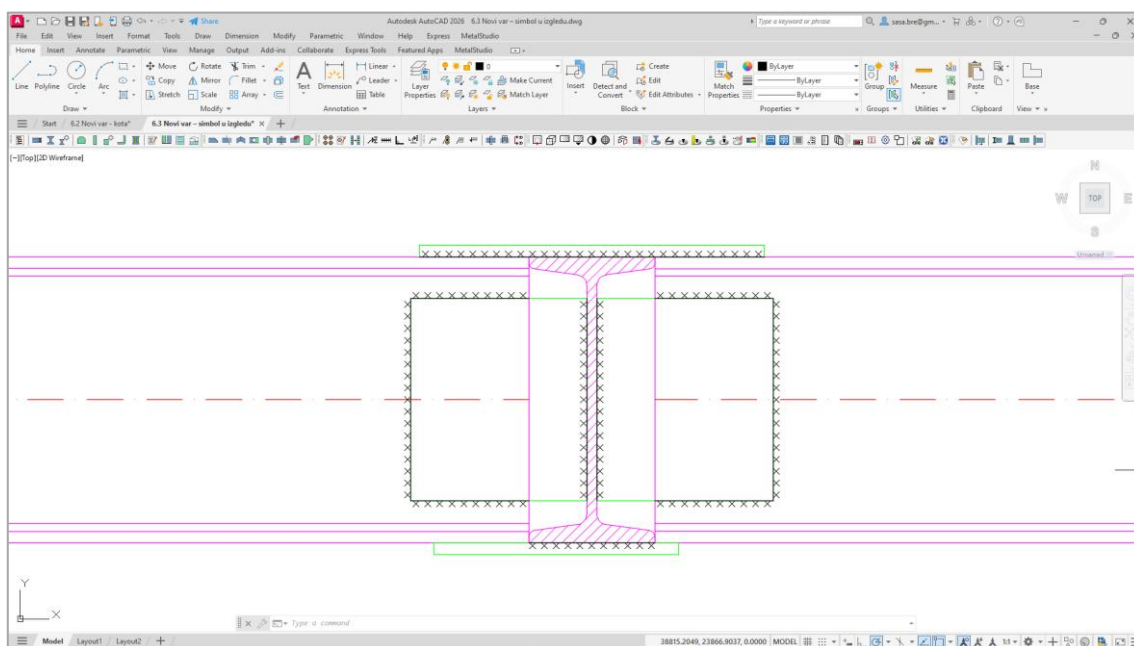

6.4 New weld – symbol in cross section

Using this command enables you to place the weld symbol in cross section. Either by selecting the **'New weld – symbol in cross section'** command from the **'Metal Studio ► Connecting devices'** drop-down menu, or by clicking on the icon , the following dialog box will open up:

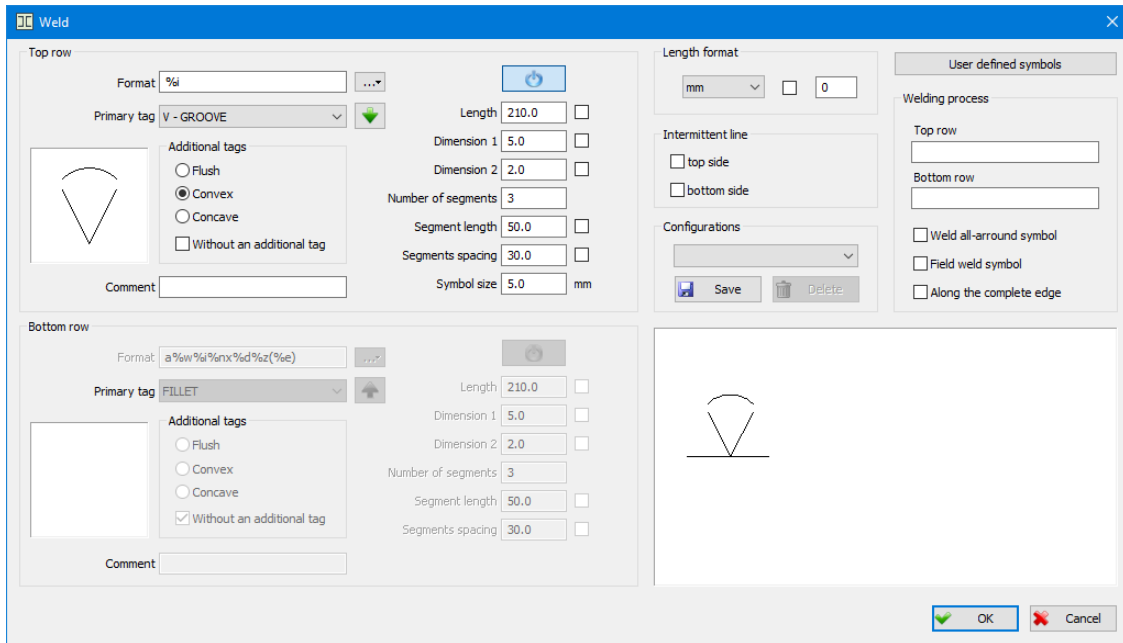

Dialog box for defining the characteristics of the weld in cross section

Working within this dialog box is same as working within the dialog box for defining the weld label, and therefore, it will not be explained again (see Chapter 6.2). Considering the nature of the weld in cross section, in this dialog box, the part containing the parameters for the definition of the appearance and the contents of the weld label below the baseline is disabled.

Depending on the placed additional tag, the weld symbol in cross section can be displayed in the drawing using **flush**, **convex** or **concave** surface.

Symbol size The edit box for assigning the size of the weld symbol in cross section.

Upon exiting the dialog box, it is necessary to chose an intersection point of the weld, and a point determining the angle the weld symbol is forming, from the drawing.

Intersection point of the weld:

First angle:

Second direction:

This command has the circular nature, and therefore, the program will still request that you determine the intersection point of the weld, until you select the **'End'** sub-option and terminate this command.

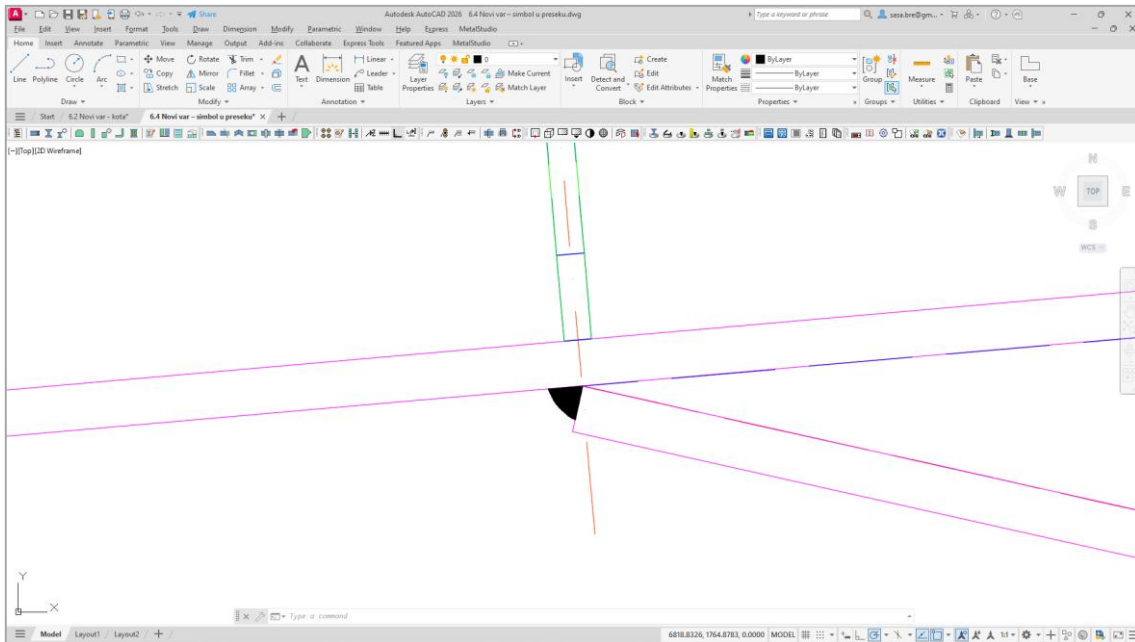

The weld symbol in cross section with the convex surface is placed on the drawing

6.5 Labeling an existing weld symbol

Using this command enables you to place the weld symbol in plan view and the weld symbol in cross section. Either by selecting the command from the **'Metal Studio ► Connecting devices'** drop-down menu or by clicking on the icon , the user is expected to choose a point from the weld he/she wants to label, to determine the start point of the label, with the command bar obtaining the following layout:

Label start point:

Upon selecting the label start point, the program will request that you specify the position of the label text by clicking.

Text position:

Finally, the program will request that you specify the angle of the text inclination in the label either by selecting a point from the drawing or by entering a numerical value using the keyboard.

Text angle:

The program will read, from the weld symbol, all the previously allocated numerical data and, in relation to them, create the label layout.

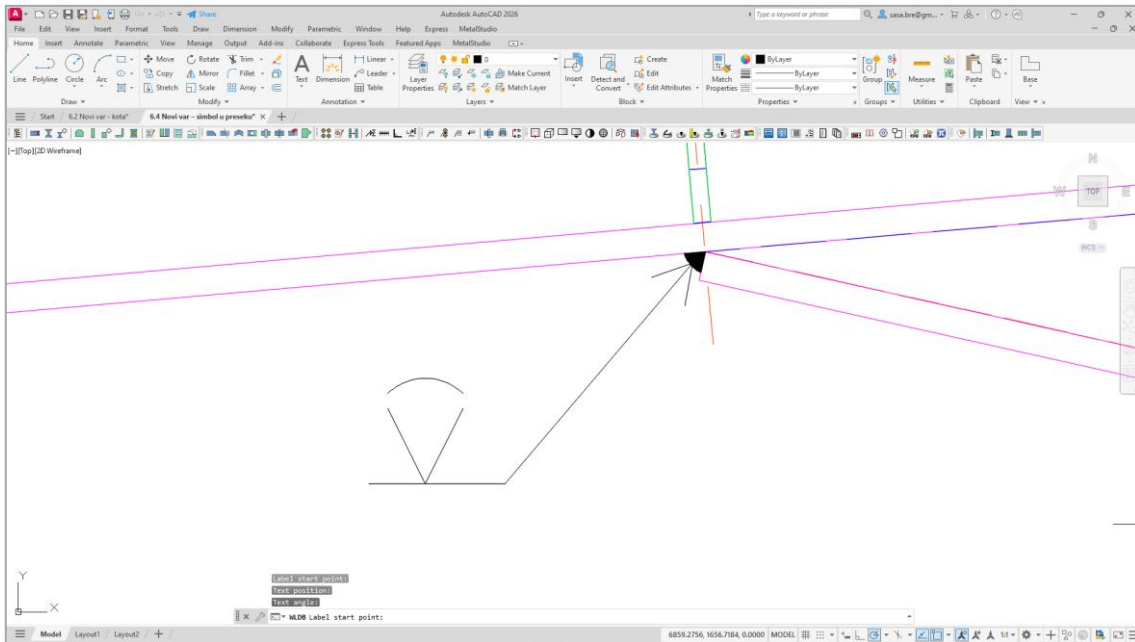

The weld symbol label in cross section is placed on the drawing

6.6 Copying the connections

Every connection of one girder with another girder or plate, can be copied, using this command, to some other place in the drawing, in case there are girders of identical cross section and mutual position, as the girders selected to be the part of that connection. By copying the connections we mean copying of all the plates, bolt series and welds selected as the source entities. Apart from that, all the necessary formings of destination girders (forming of ends, hole perforation for the bolt series ...) are performed, as well as the transformations needed for entities being copied to obtain the correct position in the drawing.

Either by selecting the command from the **'Metal Studio ► Connecting devices'** drop-down menu or by clicking on the icon , the program will request from the command bar that you select the main source girder, and then also the reference point from the axis of that girder.

Selection of the main source girder [Exit] <Exit>:

Choose the reference point from the axis of source girder:

Upon selecting the reference point, it is necessary to select all the connection entities that need to be copied. Plates, bolt series and weld symbols can be copied.

Selection of the source objects:

In case there is another girder apart from the main one, that girder also needs to be selected as the source object. This is necessary in order to copy the bolt series this girder bears, and to perforate the holes from bolt series this girder does not bear, on the corresponding destination girder.

This message will remain on the command bar until you press the right mouse button or the Enter key on the keyboard, and therefore end the selection.

Next step requires selecting the main destination girder, and then the reference point of its axis.

Selection of the main destination girder [Exit] <Exit>:

Choose the reference point from the axis of destination girder:

The main destination girder must have the same cross section as the main source girder.

After selecting the reference point, the program copies the selected entities to the assigned position and performs, on the destination girders, all the formings present on the source girders, needed for the connection creation.

7. REFERENCES

7.1 Labeling a girder or a plate

Using this command enables you to place labels on a girder, a girder plan view, a plate, a plate plan view, a girder workshop drawing and a plate workshop drawing.

Either by activating the command from the **'Metal Studio ► Reference'** drop-down menu or by clicking on the icon , the command bar will obtain the following layout:

Label start point [Set/Exit] <Exit>:

The program will now request that you specify the label start point either by selecting a point from the instance you are labeling or by choosing one of the offered sub-options.

The command will end upon selecting the **'Exit'** sub-option from the command bar, whereas upon selecting the **'Set'** sub-option, a dialog box of the following layout will open up:

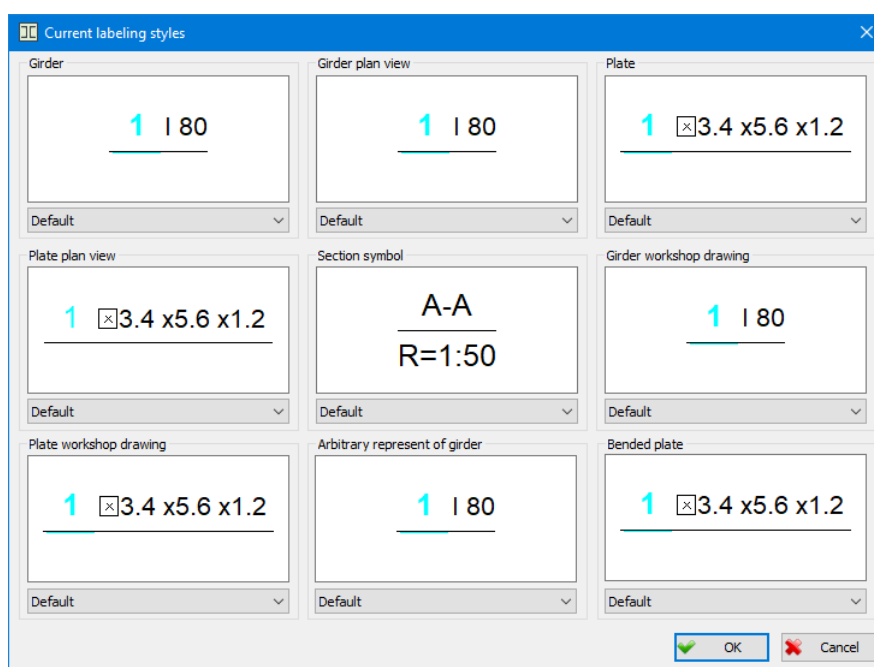

Since different entities labels do not have the same contents in this dialog box, for each entity type, there is a window intended for previewing the current labeling style, together with the combo box which contains all previously created labeling styles. Once you have selected from the combo box the desired labeling style for the entity you are labeling, you must activate the **'OK'** command field. The program will close the dialog box and return to the command for placing the label.

Upon selecting the label start point, the program will request that you specify the position of the label text by clicking.

Text position [Set/Additional/Exit] <Exit>:

Selecting the **'Additional'** option enables you to place an arbitrary number of additional label arrows, so that by using a single label you can label several instances in the drawing.

Label additional point [Exit] <Exit>:

Finally, the program will request that you specify the angle of the text inclination in the label either by selecting a point from the drawing or by entering a numerical value using the keyboard.

Text angle:

The program will read, from the given instance, all the previously allocated numerical data and, depending on the selected labeling style, create the label layout.

If, during specifying the label start point, you click on an empty part of the drawing rather than in the instance vicinity, the program will request (in the same way as in the previously described procedure) that you specify the position of the label text by clicking. This time, however, the label contents will include data for all instances which have been intersected by the assigned label line. The number of rows in thus created label will correspond to the number of intersection points between the label line and the instances in the drawing, whereas their position will clearly indicate by height the instance to which the given label is related to. In this way, several independent labels which overlap the label lines along the assigned intersection line are created practically at the same time. Finally, we would like to emphasize that additional label arrows cannot be assigned during such labeling.

7.2 Bolts label

Using this command enables you to label all the bolts positioned in the drawing, both material and immaterial (bolt plan view). Either by selecting the command from the '**Metal Studio ► Reference**' drop-down menu or by clicking on the icon , the following dialog box will open up:

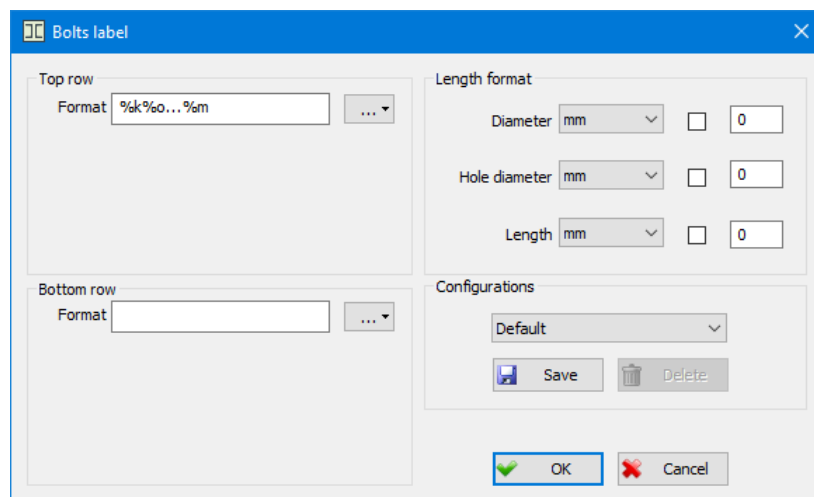

Top row

This part of the dialog box defines the contents of the bolt label above the baseline.

Format

The edit box for defining the bolt label contents above the label baseline. Clicking the  button, which is in the continuation of the edit box, will result in the opening the drop-down menu for selecting the parameters to be displayed in the bolt label. A short description which clearly indicates what the given parameter represents in the label is written in the continuation of each parameter symbol. Selecting the desired parameter is performed simply by clicking upon which the program will close the drop-down menu and the selected parameter will be placed in the edit box. You can also assign all these

parameters directly in the edit box, by entering their symbol using the keyboard. Also, you can use the keyboard to enter an arbitrary text in the edit box. This program option is mostly used for describing specific data in the label text.

Bottom row This part of the dialog box defines the contents of the bolt label below the baseline. Working within this dialog box is the same as working within the dialog box for defining the contents of the weld label above the baseline, and therefore will not be explained again.

Length format The selection of the units used for the bolt definition is performed from the combo box. Displaying the selected units in the label is adjusted individually for each dimension (**diameter of the bolt body, diameter of the hole, and bolt length**) by using appropriate check boxes. The number of decimal places with which weld dimensions will be displayed in the label is assigned in the displayed edit box.

Configurations:

Any previously saved configuration can be selected from the lists to represent the current one.



Save

The configuration with the current state of parameters in the dialog box is saved in the database.



Delete

Deleting the current configuration from the database.

Clicking the **'OK'** button will result in closing the dialog box, and the program will request from the command bar that you enter the label start point.

Label start point [Set]:

You can open the same dialog box via the **'Set'** option, if you need to change the label contents. Upon entering the label start point, the program will request that you specify the position of the label text by clicking.

Text position [Additional]:

Upon selecting the **'Additional'** option, you will start the procedure of placing an arbitrary number of additional label arrows, so that, by using a single label, you can mark the position of several identical bolt series in the drawing.

Label additional point [Exit] <Exit>:

Finally, the program will request that you specify the angle of the text inclination in the label either by selecting a point from the drawing or by entering a numerical value using the keyboard.

Text angle:

Upon this, the created bolt label is placed on the drawing.

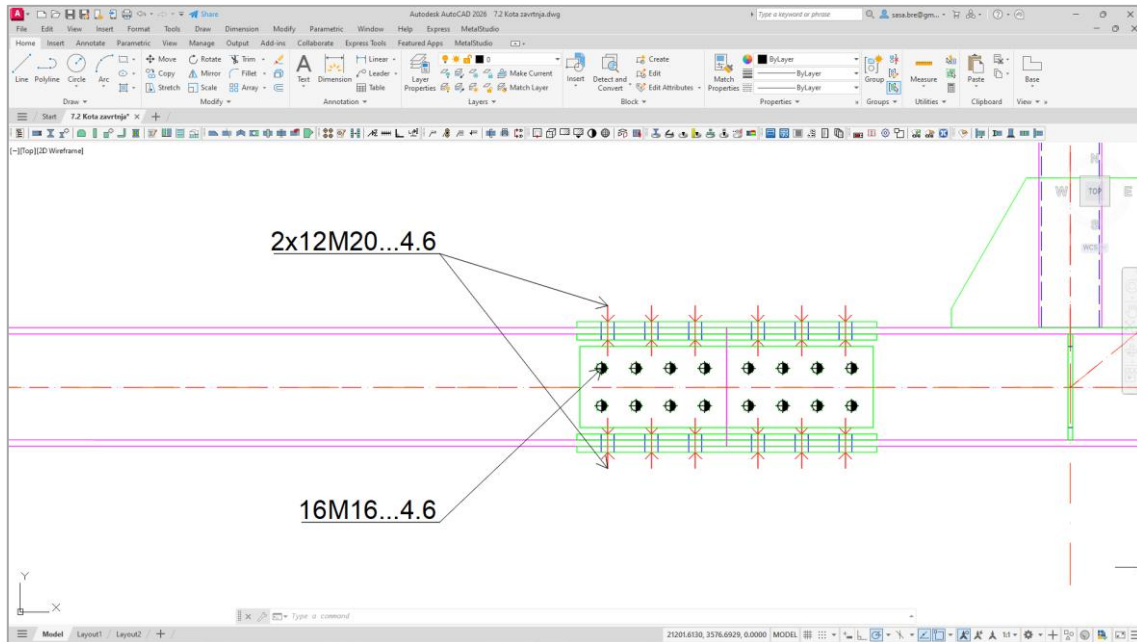

7.3 Arbitrary label

Using this command enables you to place arbitrary labels anywhere in the drawing. Either by selecting the command from the **'Metal Studio ► Reference'** drop-down menu or by clicking on the icon , the program will request from the command bar that you enter the label start point, whereas the label contents is entered in the 'floating' dialog box which opens up at the same time:

Label start point:

Top row

This part of the dialog box defines the contents of an arbitrary label above the baseline, by entering an arbitrary text in the edit box using the keyboard. Considering the fact the contents of the label is automatically saved, you can chose one of the previously defined contents from the combo box, at any time.

Activating the button , which is located in the continuation of this combo box, deletes the currently chosen label contents from the list.

Bottom row

This part of the dialog box defines the contents of an arbitrary label below the baseline. Working within this dialog box is the same as working within the dialog box for defining the contents of the label above the baseline, and therefore will not be explained again.

Upon defining the contents of an arbitrary label and selecting the start point, the program will request that you specify the position of the label text by clicking.

Text position [Additional]:

Upon selecting the **'Additional'** option, you will start the procedure of placing an arbitrary number of additional label arrows, so that, by using a single label, you can mark the several positions in the drawing.

Label additional point (Exit) <Exit>:

Finally, the program will request that you specify the angle of the text inclination in the label either by selecting a point from the drawing or by entering a numerical value using the keyboard.

Text angle:

Upon this, the created arbitrary label is placed on the drawing.

7.4 Elevation label



Using this command enables you to place elevation labels in the drawing. Either by selecting the command from the **'Metal Studio ► Reference'** drop-down menu or by clicking on the icon , the following message will appear on the command bar:

Label start point [Reference point]:

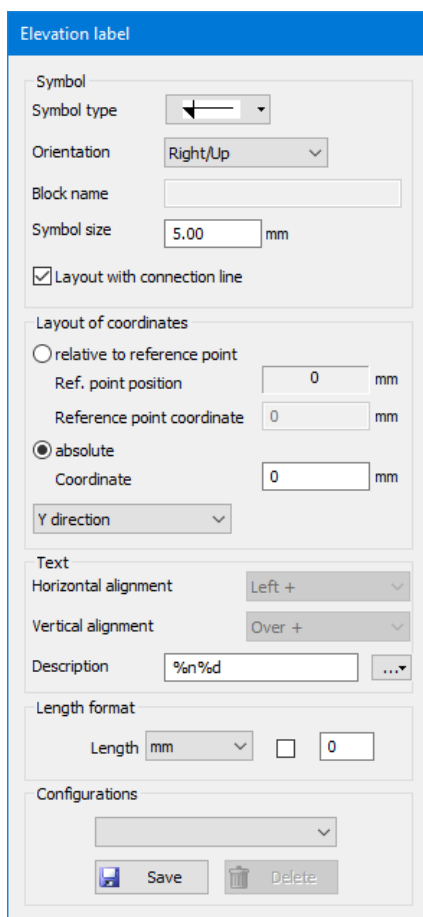

At the same time, the floating dialog opens up, where all the necessary data for creating the elevation label is assigned.



Elevation label

Symbol
 Symbol type: 
 Orientation: Right/Up 
 Block name:
 Symbol size: 5.00 mm
 Layout with connection line

Layout of coordinates
 relative to reference point
 Ref. point position: 0 mm
 Reference point coordinate: 0 mm
 absolute
 Coordinate: 0 mm
 Y direction: 

Text
 Horizontal alignment: Left + 
 Vertical alignment: Over + 
 Description: %n%d 

Length format
 Length: mm  0

Configurations

Symbol:

Symbol type The list for choosing one of the elevation label symbols, intended by program. Apart from the symbols, list offers the choice for the option 'BLOCK', which means that the elevation label symbol that the user independently created is placed in the drawing. These symbols are created under the same rules that stand for the shape symbols (Chapter 1.6), and must be placed in the current drawing or database SymDim.dwg (or some other database that was chosen, within the command 'Functionality', as a database, with symbols for the label).

Orientation The list for choosing the orientation of the elevation label symbol. Option '**Right/Up**' indicates that the symbol is oriented towards right, for the Y direction of placement, i.e. towards up, for the X direction. Option '**Left/Down**' indicates that the symbol is oriented towards left, for the Y direction of placement, i.e. towards down, for the X direction. This list is not available when symbol created by the user independently is being placed.

Block name The edit box for entering the block name with the elevation label symbol, which was created by the user. This edit box is available solely in case the option 'BLOCK' is chosen from the 'Symbol type' list.

Symbol size The edit box for assigning the size of the elevation label symbol, in millimeters on the paper.

Layout with connection line

When this check box is on, a line is drawn between the label start point and the symbol.

Layout of coordinates:**relative to reference point**

When this switch is on, distance between reference point and start point, enlarged for the value entered in the edit box '**Reference point coordinate**', is displayed in the label. This box contains the assigned value that will be displayed in the elevation label when start point and reference point have the same coordinate in the direction the elevation label is placed in. The position of reference point is assigned by choosing the option '**Reference point**' from the command bar, and is displayed in the box '**Ref. point position**'.

absolute When this switch is on, the value assigned in the edit box '**Coordinate**' is displayed in the label.

List for selection of labeling direction

Y direction – distances in the direction of Y axis of global coordinate system (World UCS) are labeled.

X direction – distances in the direction of X axis of global coordinate system (World UCS) are labeled.

Text:**Horizontal alignment**

The list for choosing the horizontal alignment of the text, when symbols created by the user are placed in the label. Alignment is performed in relation to the reference point for placement of the symbols, which was chosen during the creation of the block with symbol. Sign + in the names of some options from the list means that the alignment is performed for the half of provided symbol size.

Vertical alignment

The list for choosing the vertical alignment of the text, when symbols created by the user are placed in the label.

Description

The edit box for defining the content of the elevation label text. By activating the button, which is in the continuation of this edit box placed, a drop-down menu for the selection of the parameters that can be displayed in the label text will open up.

Length format: From the combo box, the units (m, cm, mm, ...) are chosen for the display of the distances in the elevation label. The state of the check box determines whether the tag for the chosen units is displayed in the label, while the number of decimal places for displaying the distance is assigned in the edit box.

Configurations:

Any previously saved configuration can be chosen from the combo box.

 **Save**

The button upon activating which, under arbitrary assigned name, the state of parameters defined in this dialog box is saved.

 **Delete**

The button upon activating which the current configuration will be removed from the list.

When all the data necessary for creating the elevation label is assigned in the dialog box, firstly, start point is assigned by choosing a point from the drawing, and secondly, the point determining the label position in the drawing assigned.

Label start point [Reference point]:

Label position:

In the next step, the elevation label will be placed in the drawing.

7.5 Cross-section pursuit

Using this command enables you to create two types of cross sections:

Section without width Only the section of the entity at the place of the assigned intersection line is placed in the drawing.

Section with width Next to the intersection line, the section length is also assigned, by which a rectangular area is formed. The section of the entity at the place of the assigned intersection line, together with the projection of all entities found within the assigned area, is placed in the drawing.

Copying of the entity to some other place in the drawing can also be performed, along with rotation for 90 degrees.

Either by selecting the '**Cross-section pursuit**' command from the '**Metal Studio ► Reference**' drop-down menu or by clicking on the icon , the program will request from the command bar that you specify the intersection line first point. At the same time, a floating dialog box which is used for assigning additional parameters for the cross section pursuit will open up.

First point:

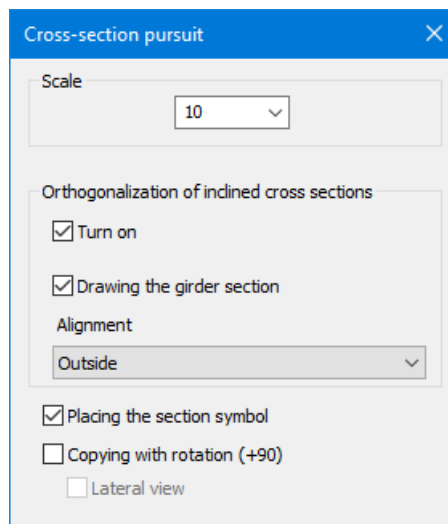

Scale Assigning the scale of the cross section to be pursued.

Orthogonalization of inclined cross sections:

The parameters displayed in this part of the dialog box affect the cross section pursuit from girders which are intersected by the assigned intersection line at an angle other than 90 degrees.

Turn on When this check box is on, the program idealizes the pursued cross section from the girders. In other words, the program pursues the cross section in the same way as when the assigned line intersects the girder at an angle of 90 degrees.

Drawing the girder section

When you perform the orthogonalization of the section with width in such girders, as a result, you get two parts: the idealized girder cross section and the projection of the girder part which is located within the assigned area on the intersection line (girder plan view). The state of this check box determines whether the idealized girder cross section will at all be placed in the drawing.

Alignment Whenever section with width is pursued, this combo box is used for selecting the alignment of the idealized girder cross section with the part obtained by projecting on the intersection line.

Placing the section symbol

Enabled check box indicates that the program will automatically be entering the procedure of placing the section symbol, by placing the section symbol (source) in the position of the provided intersection line, and the user will be specifying the text position (destination).

Copying with rotation (+90)

When this check box is on, instead of cross-section pursuit, copying with rotation for 90 around the assigned line is being performed, and it includes all the entities that line (i.e. area, in case the width is entered as well) touches. It means that it results in material instances, which differs from the case of cross-section pursuit, which results in entity plan views.

Once you select the first point, the program will request that you enter the intersection line end point,

End point:

and in the next step, that you assign the section width.

Enter width (End):

After selecting the '**End**' option, the assigned section is pursued without entering the width.

Finally, you must specify the position of the pursued section in the drawing by selecting the reference point and by assigning the section angle with respect to the horizontal.

Reference point:

In case the key Shift is pressed during the selection of the reference point, pursued cross-section may be moved solely along the vertical to the assigned cross section line, which considerably facilitates its placement in the drawing.

User is allowed to rotate the provided section display by clicking the 'Control' button using the keyboard, to the closer of the two directions - X or Y directions.

Angle:

Enabled check box 'Placing the section symbol' indicates that the program entered the procedure of placing the section symbol. It will place the section symbol (source) in the position of the provided intersection line, and will request that you firstly specify the text position (destination) from the command bar

Text position (Set/Other side/Exit/Tag<1>) < Exit>:

and also the angle of the text inclination.

Text direction:

This procedure is specified within the 'Section symbol' command (see Chapter '7.6').

If the copying is performed along with the rotation, the command will have slightly different course. After assigning the width, we must chose the point that will be used for determining the position of copied and rotated entities in the Z axis direction.

Choose the reference point for determining the height:

After selecting the reference point, we must also assign the Z coordinate it will have during the placement of these entities in the drawing.

Reference point height <0>:

Further course of the command is the same as in case of cross-section pursuit, and by selecting the point and assigning the angle, we determine the position of these entities in the drawing.

7.6 2D Cutout

Using this command enables you to select and place as a special drawing any part of the previously drawn model. The command is mostly used for displaying part of the structure (truss nodes, connections among entities etc.) in a scale which differs from the main drawing.

Either by selecting the '**2D Cutout**', from the '**Metal Studio ► Reference**' drop-down menu or by clicking on the icon , you will start the procedure of assigning an arbitrary closed polyline with the purpose of selecting part of the drawing for placing details, whereas the scale of the pursued detail is entered 'floating' dialog box which opens up at the same time.

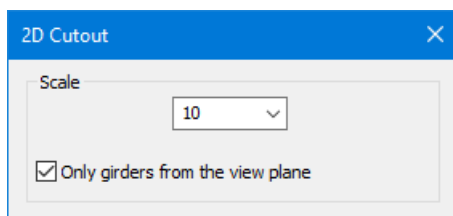

Scale The edit box for assigning the scale of the pursued detail. Scale can be entered by assigning the values using the keyboard, or by choosing one of the scales already defined by the program, located in the continuation of this edit box.

Only girders from the view plane

If the check box is set to the on state, then the detail will contain only the girders located in the view plane, while the girders perpendicular to the view plane will not be displayed. By turning off the check box in the extracted detail, all girders will be displayed.

Either by activating the '**2D Cutout**' command from the '**Metal Studio ► Reference**' drop-down menu or by clicking on the icon , you will start the procedure of assigning an arbitrary closed polyline using which part of the drawing is selected for placing details.

First point [Rectangle/Circle]:

Rectangle Selecting part of the drawing is performed by assigning a rectangular area.

Circle Selecting part of the drawing is performed by assigning a circular area.

Finally, you must specify the position of the pursued detail in the drawing by selecting the reference point and by assigning the section angle with respect to the horizontal.

Reference point:

Angle:

7.7 Section symbol

Using the '**Section symbol**' command enables you to place in the drawing a symbol which will indicate where in a model a section has been pursued. The section symbol consists of two parts:

Source the symbol which is placed at the place where a given section has been pursued in the structure.

Destination the text which is placed at the place where a given section is located in the drawing.

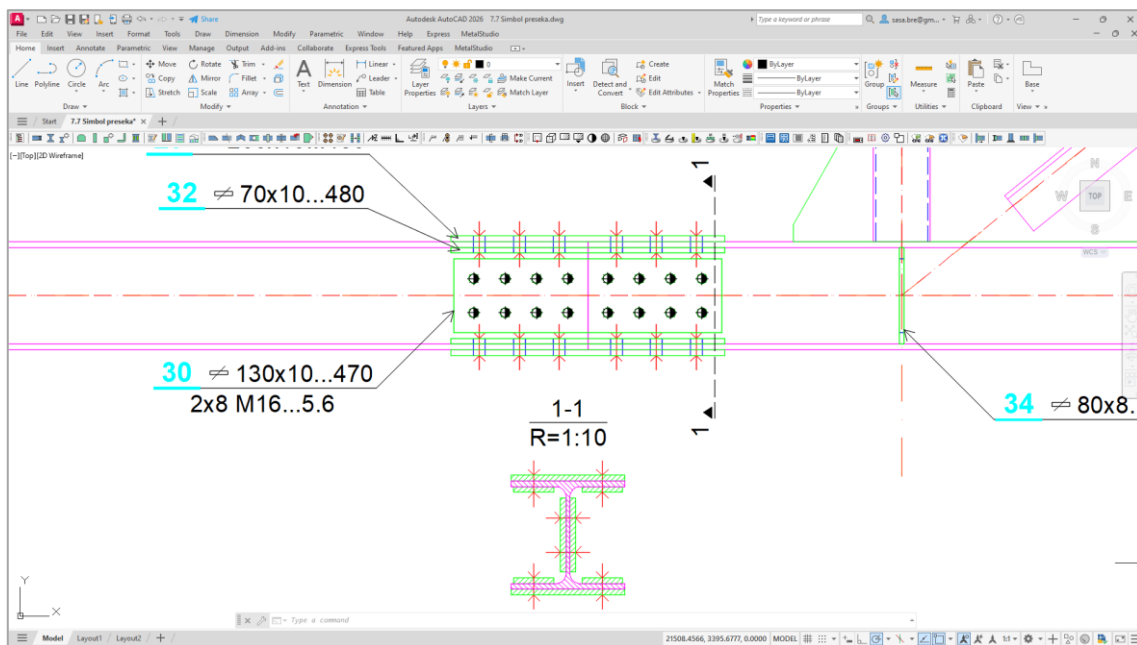

You can adjust the layout of the section symbol to meet your needs using the 'Drawing parameters' and 'Labeling styles' commands.

Either by activating the '**Section symbol**' command from the '**Metal Studio ► Reference**' drop-down menu or by clicking on the icon , the message in which you are requested to specify the first point will appear on the command bar.

First point:

Now you are requested to specify the intersection line end point.

End point:

Upon selecting these points, the program will display in the drag mode the layout of the placed section symbol, and a new message will appear on the command bar.

Text position [Set/Other side/Exit/sCale<1:10>/Tag<1>] <Exit>:

Now you must either assign the point which will specify the text position or select one of the offered sub-options.

Exit Ending the command.

- Set** Opens the dialog box for selecting one of the previously defined styles of section symbol. Section symbol styles are defined using the 'Labeling styles' command.
- Other side** Copying the placed section symbol with respect to the intersection line in order to obtain its mirrored transformation.
- Scale** The program writes the scale of the entire drawing in parentheses which are behind the 'Scale' sub-option. If it is different from the cross section scale, selecting this sub-option will enable you to assign, in the section symbol text, the scale with which the cross section has been placed in the drawing.
- Tag** The program writes the section symbol tag in parentheses which are behind the 'Tag' sub-option. By default, both source and destination contain a tag and it serves for connecting these two parts of the section symbol. By selecting this sub-option, you can assign a completely arbitrary text for the the section symbol tag.

Once you have assigned the section symbol text position, you must specify the angle of the text inclination either by selecting a point from the drawing or by entering a numerical value using the keyboard, upon which the command will end.

Text direction:

8. EDITING ENTITIES

8.1 Database of positions

Either by selecting the 'Database of positions' command from the 'Metal Studio' drop-down menu or by clicking on the icon , a dialog box of the following layout will open up:

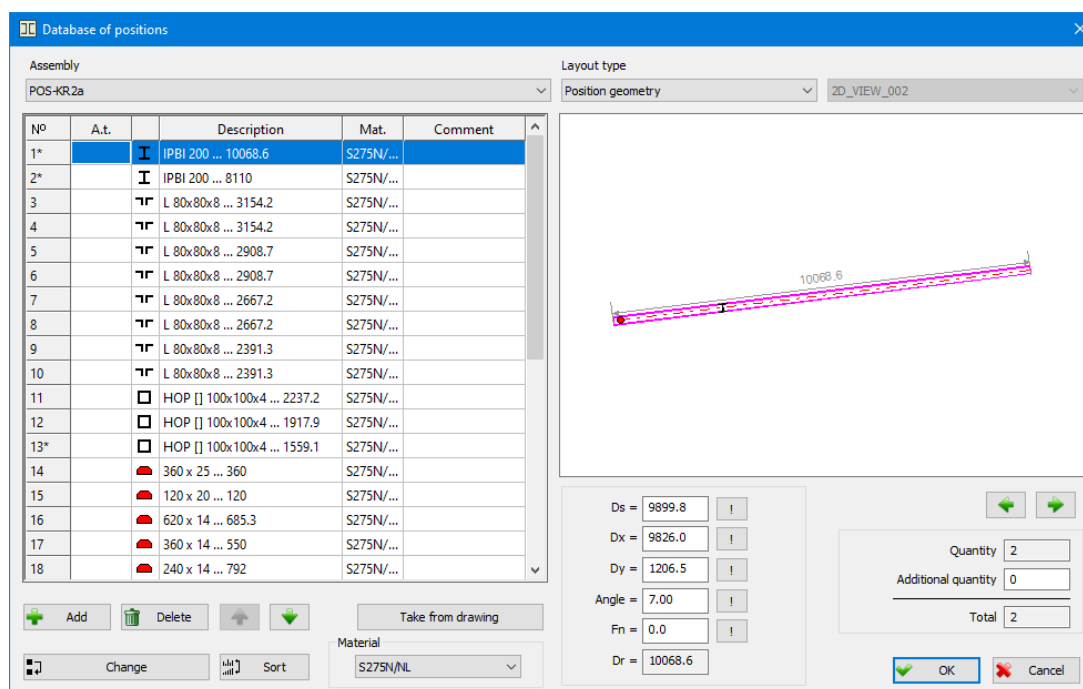

The dialog box within the 'Database of positions' command - the layout

Assembly The combo box which allows you to set as the current one any of the previously defined assembly positions.

The left part of the dialog box displays the list containing all previously defined girders and plates positions within the current assembly position. The meaning of each column in the list is the same as in the previously described command 'Existing girder'.

In the right part of the dialog box, there is a window intended for displaying the geometry of the selected positions.

Layout type The combo box which allows you to set as the current one any of the three methods intended for displaying the selected position.

Position geometry – the selected position geometry is displayed.

Girders and plates of the selected assembly - the instances of all girders and plates positions from the current assembly are displayed, whereas the placing of the instances of the selected positions is clearly marked.

All girders and plates – the instances of all girders and plates positions from all assemblies positions are displayed, whereas the placing of the selected position instances is clearly marked.

If you are in the '3D modeling' operating mode, and the display of elements from the current assembly or all elements is selected from the list, a list will become available from which it is possible to select one of the viewports that are set in the views. Then the position of the position instances in the selected view will be displayed in the window.

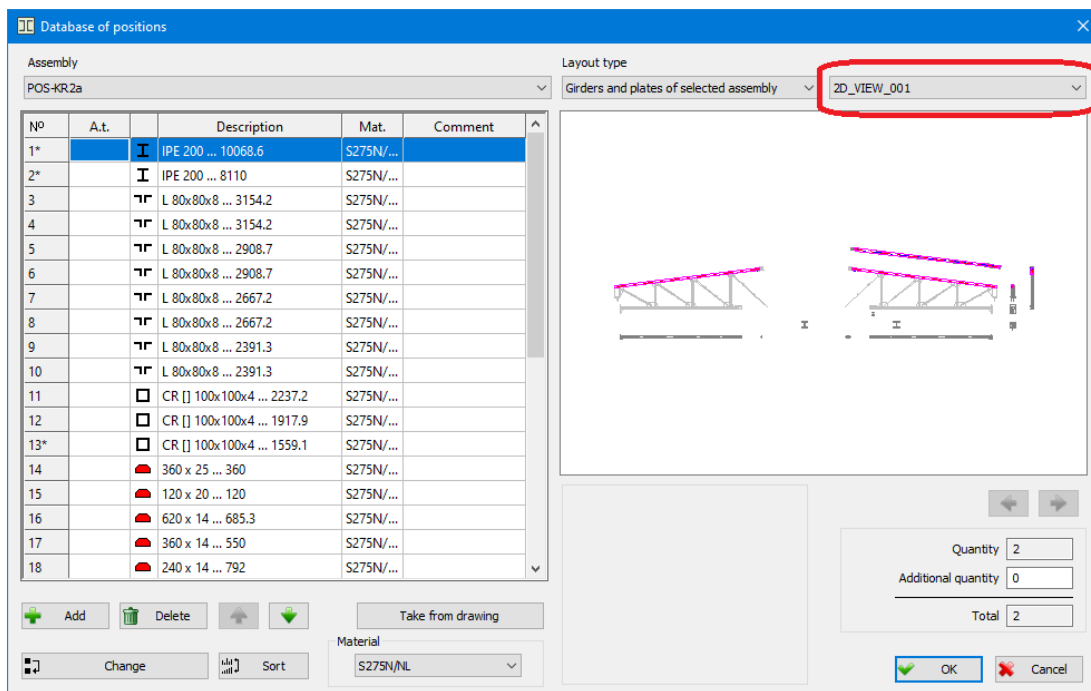

A list of view names that are set in viewports



Since a single girder or plate position may have several instances which can take different positions in the drawing, this button enables you to move the layout of the selected position geometry into the position of any instance from the drawing.

Quantity Total quantity of girders or plates of the selected position which has been added to all instances in the drawing.

Additional quantity This edit box allows you to assign for the selected girder or plate position an arbitrary additional quantity which is not displayed in the drawing.

Total Total quantity of girders or plates of the selected position to be included in the specification, i.e. the sum of values in the fields 'Quantity' and 'Additional quantity'.

Below the layout of the selected position geometry, there are edit boxes with numerical data which specify the geometry of the given position.

If a girder position is selected, the displayed edit boxes have the following meaning:

- Ds =** the axis length of the selected position
- Dx =** the length of the axis horizontal projection
- Dy =** the length of the axis vertical projection
- Angle =** the girder axis angle of inclination with respect to the horizontal
- Fn =** the arch girder rise (Fn=0 value denotes that the girder is straight)
- Dr =** the real length of the selected position girder



The button upon activating which taking directly from the drawing is made possible and selecting two points whose mutual spacing will determine the required value to be placed in an appropriate edit box.

In the displayed geometry of the selected position, an immovable point is marked with a red round dot. The program will by default place this point in the girder axis first point. Changing its position is performed by clicking either the axis end or middle point. By selecting this point, you can define the point which will not change its position in the drawing whenever the girder geometry is changed. For example, if you select the girder axis end point as the immovable point and then you change the girder length, as a result, the end point will not change its position in the drawing. On the other hand, if a plate position is selected, three new edit boxes which have the following meaning will appear:

width The width of the selected plate position.

length The length of the selected plate position.

thickness The thickness of the selected plate position.

Plate forming The button upon activating which a dialog box for forming plates will open up.

Take from drawing

Clicking on this button opens the drawing to select an entity (girder or plate) whose assembly and position will be set as current when returning to the dialog.

Material The combo box for selecting one of the previously defined steel types.



Add

The button upon activating which a new position which has the same geometry and the same numerical data as the position which has been selected at the moment of adding is inserted into the list, in the first empty place. This newly add position has a column marked with a pink symbol, meaning it has no instance in the drawing and that its quantity equals zero.



Delete

The button upon activating which all selected positions will be removed from the drawing.



The button upon activating which the position of the currently selected position is changed by moving upwards in the list.



The button upon activating which the position of the currently selected position is changed by moving downwards in the list.



Change

Activating this button results in opening a new dialog box which enables you to change both the position number and the assembly position to which it belongs.

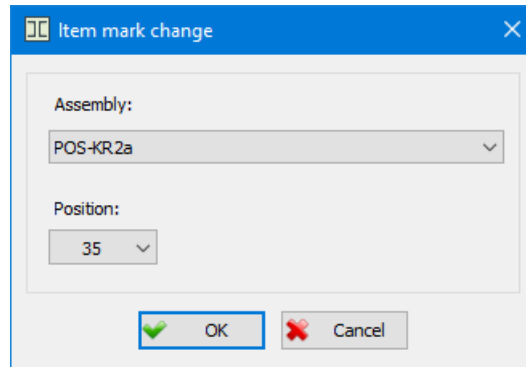

The dialog box for changing the position number and assembly position - the layout

Assembly The combo box for selecting one of the previously defined assembly positions.

Position The combo box which displays all free positions corresponding to the currently set assembly position.

Upon clicking the 'OK' button, the program will return to the basic layout of the dialog box in this command and update the positions list according to the newly-assigned data.

 **Sort** The button upon activating which a dialog box of the following layout will open up:

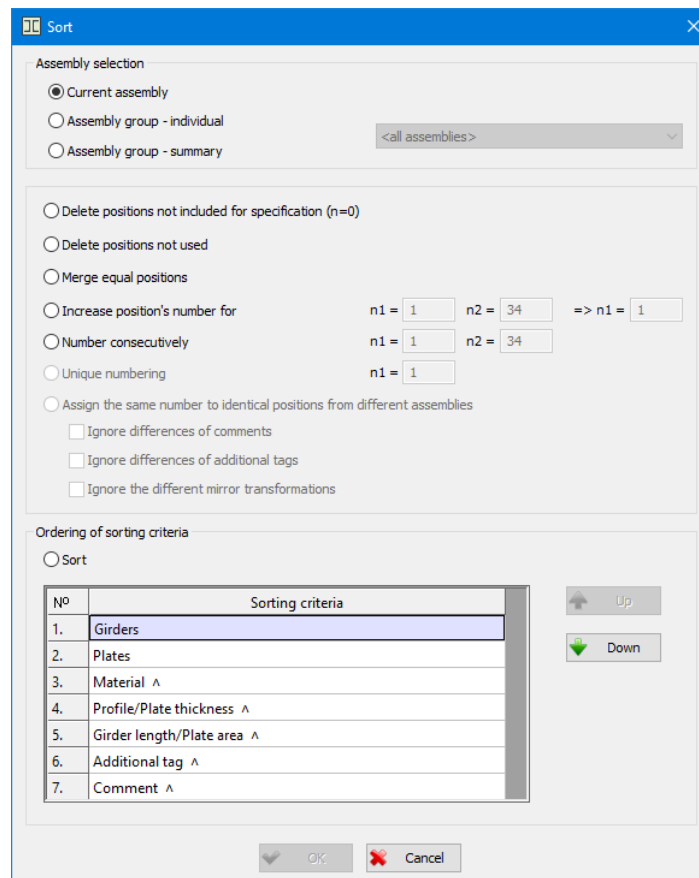

The dialog box for sorting positions - the layout

Current assembly

Only positions that belong to the current assembly are sorted.

Assembly group – individual

Positions from all assemblies belonging to the selected group are sorted. The selection of the assembly group is made from the closed list located next to this switch. Sorting is done for each assembly separately. The effect is the same as if the assemblies belonging to the selected group were set to current one by one in order to sort positions with the same criteria for each of them.

Assembly group - summary

Items from all assemblies belonging to the selected group are sorted together.

Delete positions not included for specification (n=0)

All positions whose quantity equals zero (positions whose column is marked with a pink symbol) will be removed from the list whereas their instances (if there are any) will be deleted from the drawing.

Delete positions not used

Removes all the completely empty positions from the list, i.e. positions without the instances and additional quantity.

Merge equal positions

All positions which have exactly the same geometry will merge into a single position.

Increase position's number for

This criterion enables you to change the order of positions group in the list. The ordinal number of the first or the last position from the positions group whose position is being changed is entered in the edit boxes '**n1=**' and '**n2=**', whereas a new ordinal number value of the first position in the group is entered in the edit box '**=> n1=**'. In this way, you are practically moving the selected positions group in the list to the position which is defined by the new ordinal number of the first position in the group.

Number consecutively

Since, during working, it quite often happens that some ordinal numbers in the positions list remain still available – in other words, that there are no positions with these ordinal numbers (due to deleting positions, discarding empty positions, etc) – using this criterion will enable you to update the list so that positions from the selected group (the ordinal number of the first position is entered in the edit box '**n1=**' whereas the ordinal number of the last position in the group is entered in the edit box '**n2=**') are marked with consecutive ordinal numbers.

Unique numbering

This criterion is only available when sorting for 'Assembly Group -summary'. All positions of girders and plates, from all assemblies belonging to the selected group, are numbered together, which means that each of them will have a unique serial number. The initial numbering number is set in the edit box '**n1**', which is in the extension of the criteria name.

Assign the same number to identical positions from different assemblies

This criterion is only available when sorting for 'Assembly Group - Collective'. In case the different assemblies contain identical positions, the user is allowed to assign them the same ordinal numbers by enabling this check box.

Ignore differences of comments

This check box is enabled solely in case the check box 'Assign the same number to identical positions from different assemblies' is active, and the identical ordinal number is assigned to identical

positions from different assemblies, regardless of their comments being identical or different.



Ignore differences of additional tags

This check box is enabled solely in case the check box 'Assign the same number to identical positions from different assemblies' is active, and the identical ordinal number is assigned to identical positions from different assemblies, regardless of their tags being identical or different.

Ignore the different mirror transformations

This check box is enabled solely in case the check box 'Assign the same number to identical positions from different assemblies'. Considering the fact that the program allows automatic position disclosure of the girders of specific cross sections and formings, that contained, due to different mirror transformations of their instances, unidentical girders, it is possible to separate such positions into two different positions. Enabling the check box 'Ignore difference from mirroring transformations' the program will assign the identical ordinal number to identical positions from different assemblies, without separating positions into two different positions, regardless of the fact that its instances contain different mirror transformations

Sort

When this checkbox is on, sorting of items is done by criteria displayed in the table. Importance of each criterion depends on its position, which can be adjusted by buttons  **Up** i  **Down**.

Sorting criteria

This table contains the criteria for the automatic sorting, and the ordinal number in the column '**No**' specifies their priority. The strongest criterion is the one positioned first in the table, and the weakest criterion is the one positioned last. This indicates that if the criterion '**Girders**' is positioned first in the table, and the criterion '**Plates**' is position second, all the girders from the position database list will be moved towards the beginning of the list, with the plates below them in the list, whereas the sorting will be performed on the basis of the other criteria:

'Material' - girders and plates will be sorted on the basis of the steel types.

'Profile/Plate thickness' - girders and plates will be sorted on the basis of the shape, or the plate thickness, from larger to smaller shapes, or from larger to smaller plate thicknesses.

'Girder length/Plate area' - girders and plates will be sorted on the basis of the length, or surface, from larger to smaller girder lengths, or from larger to smaller plate surfaces.

'Additional tag' - girders and plates will be sorted on the basis of the additional tags.

'Comment' - girders and plates will be sorted on the basis of the additional comments.

By right-clicking the mouse over any row in the table, except for the rows 'Rods' and 'Sheets', a menu opens with the option '**Reverse order**', and its selection changes the sorting order. For example, for the criterion 'Rod length/Sheet area', the order change means that in the future the sorting will be done from shorter to longer rod lengths, that is, from smaller to larger sheet areas. After the name of the criteria with which the order can be changed, a symbol is printed that indicates whether the ascending or descending sorting order is selected.

By activating the **'OK'** command field, the program closes the dialog box and updates the list of positions in accordance with the specified sorting criteria. When updating the list of positions, after selecting one of the sorting criteria, the program will respect the previously set sorting if possible.

Finally, we will note once again that all changes made in the dialog box 'Position base' refer to all instances in the drawing that have a reference to the given sequence number of the position for which the data change was made. Selecting the command field **'OK'** will indicate the acceptance of all implemented actions in the dialog box, and the program will redo the drawing so that it corresponds to all the changes made, while the command field **'Cancel'** is intended for giving up.

8.2 'Editing entities' command

This command is universal, which means that it can be used to alter the previously assigned data for different types of entities. Subjects of editing may be:

- Girders and girder plan views
- Plates and plate plan views
- Weld plan views, weld cross sections, welds as labels
- Labels for all types of entities (labels of girders, plates, bolts, welds, arbitrary labels, elevation labels)
- Cross section symbols

Either by selecting the **'Editing entities'** command from the **'Metal Studio'** drop-down menu or by clicking on the icon , the message in which you are requested to select the entities you want to change the data for, will appear on the command bar.

Selecting objects:

Since you can change both single and multiple data, the program will, upon selecting the first entity, continue to request from the command bar that you select, until you mark the end of the procedure of selecting, either by pressing the 'Enter' key or by right-clicking. Considering the fact that by using the 'Editing entities' command you can alter the data for entities of different types, what may occur during the mass selection is that different entity types are selected. In order to avoid this, the best way is to click on one of the entities and therefore assign the type of the object this selection applies to, and to select the rest of the desired entities by assigning a rectangular area.

8.2.1 Editing girders and girder plan views

This command enables you to edit girders and all longitudinal and lateral plan views of girder. If you have selected only one girder instance, the program will open a dialog box of the similar layout as within the command for drawing girder in plan view:

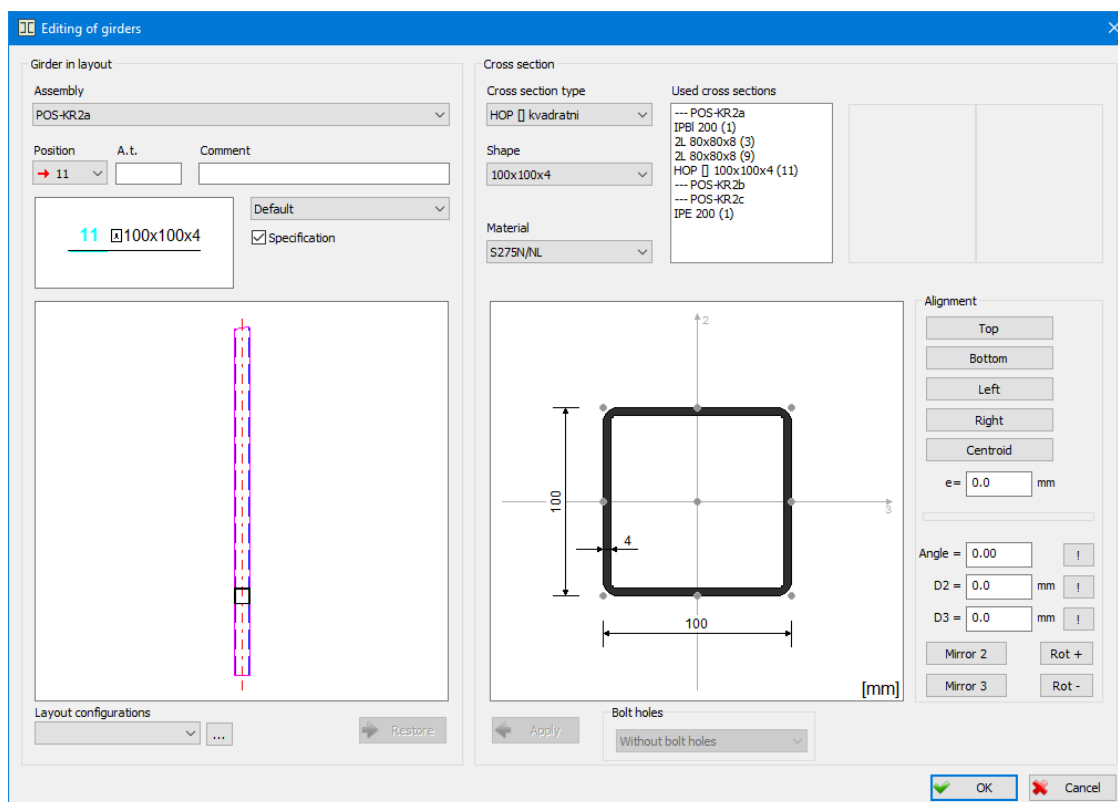

The dialog box for editing data on girders in plan view - the layout

In this dialog box, you are allowed to change freely all previously assigned data, where some of them will be added to the selected instance only, whereas others will be added to all instances of the given position. Any change of the cross section and alignment is going to affect all girders of the selected position, whereas other changes (of assembly, position, etc.) will apply to the selected instance only.

Apply

The button upon activating which the modified data on cross section are added to the selected position. This change of the cross section will be clearly seen in the left drawing in which the girder geometry is displayed. This button becomes active only if a change of cross section is made.

Restore

The button which becomes active only when cross sections in the left and right drawing in the dialog box are not the same which happens when you select a new section. Once you activate this button, you can transfer the section from the left drawing to the right drawing, by which all data related to the given section will be found in appropriate edit boxes.

Multiple data change

If you select multiple instances of girders in plan view, the program will open the same dialog box as when a single instance is selected. Data which are not the same for all the selected instances will not be displayed.

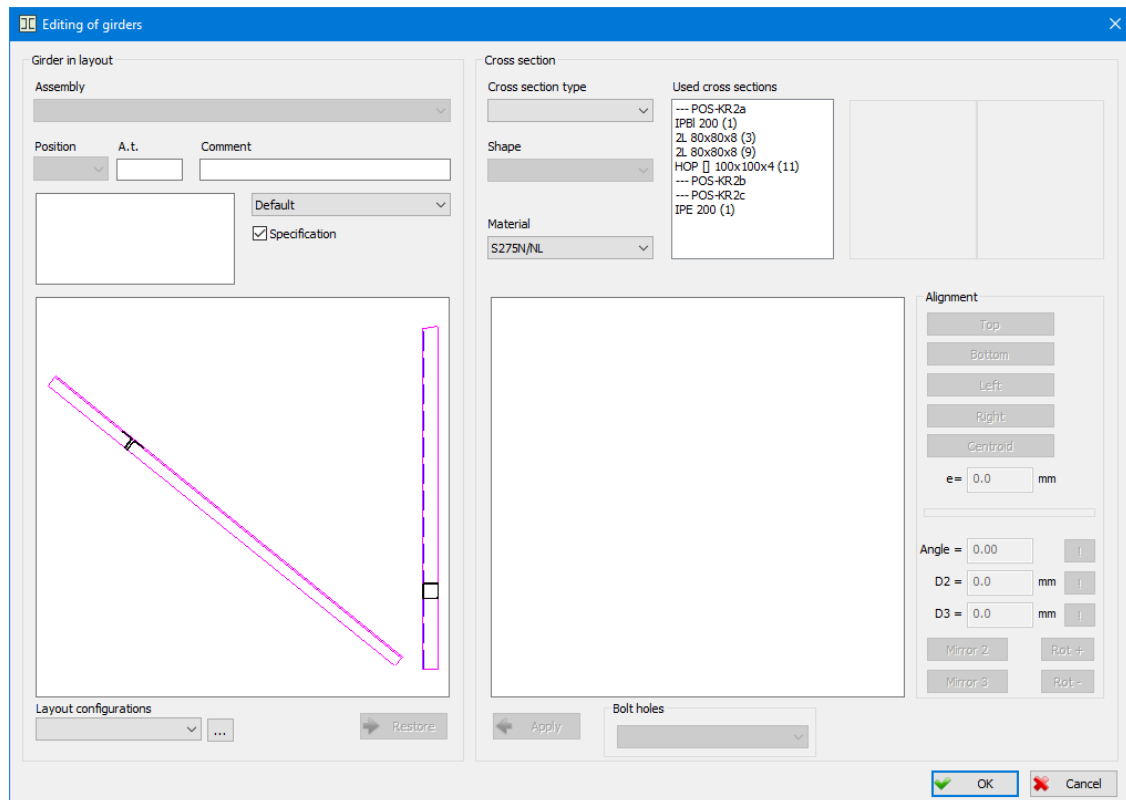

The dialog box for editing multiple data on girders in plan view - the layout

The meaning of all parameters in the dialog box as well as the methods of changing them are the same as when a single instance of girder position is selected. If girders of different shape are selected, the right drawing will be empty and all edit and combo boxes will become inactive and unavailable for change. Only when a new cross section is selected, it will be displayed in the right drawing and edit boxes will become available for change. Also, if you are changing assembly positions and girder position number, there are certain differences which depend on the selected instances from the drawing. If you select instances which belong to different girder positions or even different assembly positions, the **'Assembly'** and **'Position'** combo boxes will be frozen i.e. unavailable for change. In such cases, in order to change these data, you must activate the 'Position and assembly change' command.

After activating the **'OK'** command field, only those data which are clearly displayed in the dialog box will be added to all previously selected instances, whereas all others (empty and blurred fields) will remain unchanged.

8.2.2 Editing plates

If a single instance of plate in plan view is selected, the program will open a dialog box of the same layout as within the 'New plate in plan view' command.

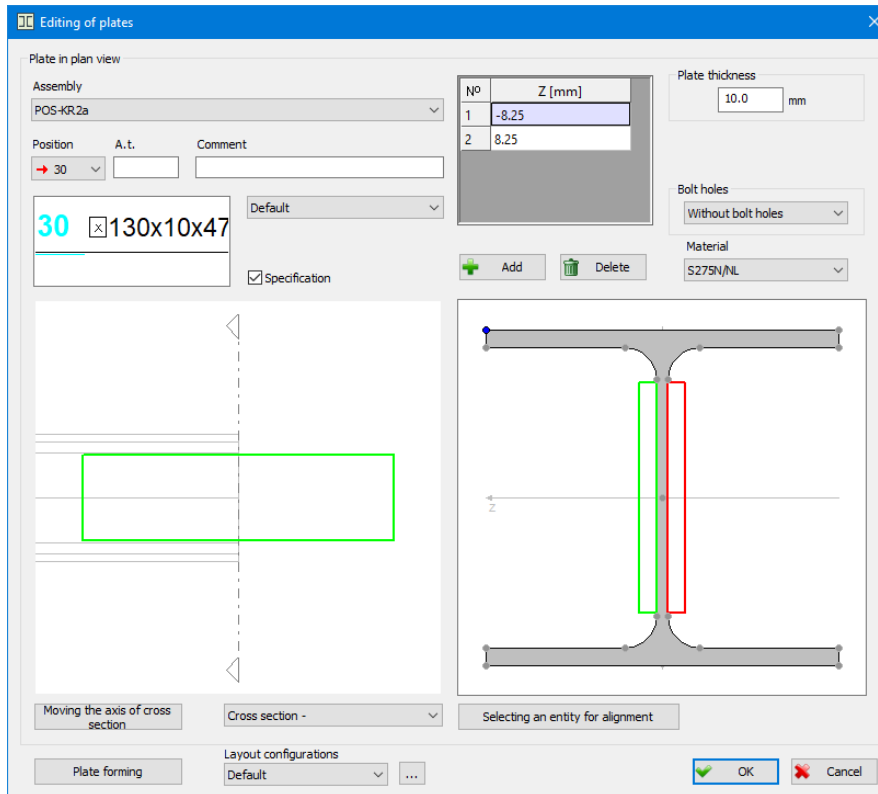

In this dialog box, you are allowed to change freely all previously assigned data, where some of them will be added to the selected instance only, whereas others will be added to all instances of the given position. Data which affect all instances of the given position are 'Plate thickness', 'Material', as well as any changes of the geometry made in the dialog box 'Plate forming'.

If only one plate instance which can be seen in cross section is selected, the program will open a dialog box of the same layout as within the 'New plate in cross section' command.

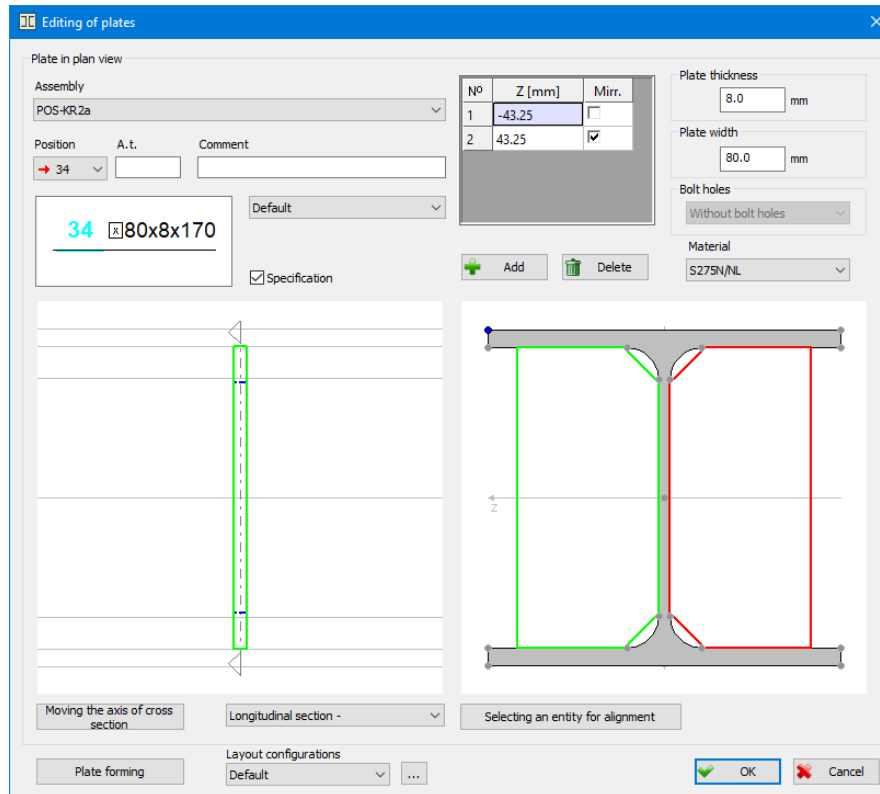

In this dialog box, you are also allowed to change all previously assigned data. Data which affect all instances of the given position are 'Plate thickness', 'Plate width', 'Material', as well as any changes of the geometry made in the 'Forming plate' dialog box.

If several instances of a plate position have been placed simultaneously using one of the commands for placing plate in the drawing and if they have retained their mutual relationship, by selecting one of them for editing, the program will select all of them.

If you select several instances of a plate in plan view i.e. in cross section, the program will open the same dialog box as when a single instance is selected. However, data which are not equal for all selected instances will not be displayed (the check boxes that do not have the same state for all selected instances will be specially marked). Also, certain data in the dialog box will be unavailable for change.

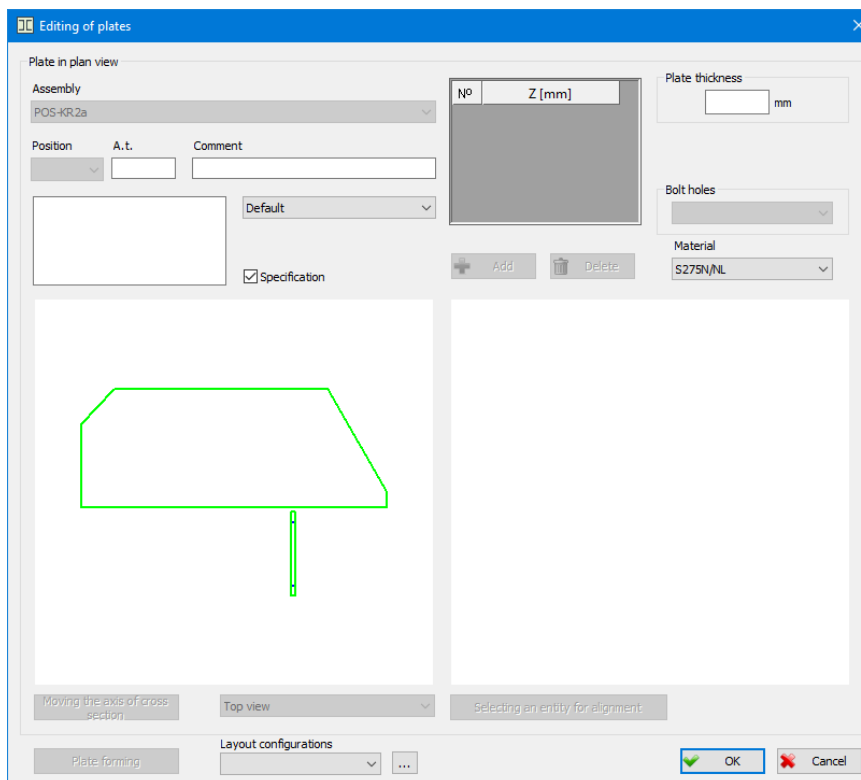

8.2.3 Editing labels

Using the universal **'Editing entities'** command enables you to change the labeling style of the selected labels from the drawing. Regardless of whether you have selected a single label or multiple labels, the program will always open the same dialog box:

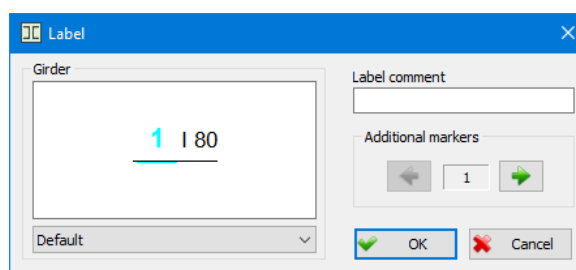



The dialog box for changing the labeling style - the layout

This dialog box works in the same way as the dialog box which opens when the 'Set' sub-option within the 'Labeling a girder or a plate' command is selected. The only difference is that now you can change the labeling styles of only those entities whose labels have been selected from the drawing.

Label comment

The edit box for assigning a label comment which will be added to all selected labels.

Additional markers

Part of the dialog box where the number of additional label markers can be changed by using the appropriate  or  arrows. These pointers can be placed into desired spot, upon exiting the dialog box, by 'gripping'. The current number of the pointers of the selected label is shown between the arrows.

Once you have selected the desired labeling styles from the combo box, you must activate the **'OK'** command field, upon which the program will close the dialog box and all selected labels will be modified according to the selected labeling styles.

8.2.4 Editing section symbol

Using the universal **'Editing entities'** command enables you also to change the parameters which affect the layout of the selected section symbols. In other words, upon activating this command, if you have selected only one section symbol from the drawing, a dialog box of the following layout will open up :

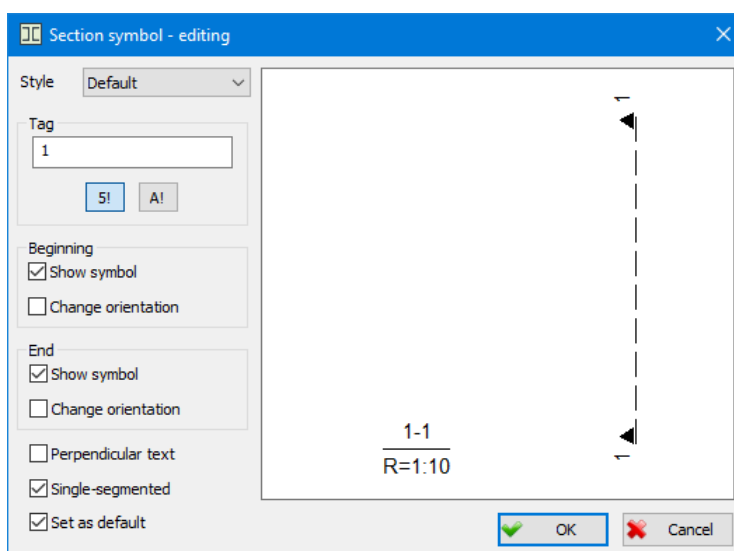

The right part of the dialog box displays the layout of the selected section symbol, whereas the left part of the dialog box contains the parameters you can change.

Style This combo box contains all styles of section symbols which have been earlier created via the 'Labeling styles' command. Selecting one of them will enable you to change the style of the selected section symbol.

Tag Part of the 'Tag' dialog box contains the parameters which affect the section symbol tag. When the **'5!'** switch is on, you can assign any positive whole number in the edit box for section symbol tag. However, keep in mind that when you turn on this switch, the program will automatically write the first free number in the edit box. When the **'A!'** switch is on, you can assign any capital letter in the edit box. Also, keep in mind that when you turn on this switch, the program will automatically write the first free capital letter in the edit box. When both switches are off, you can assign in the edit box a completely arbitrary text for the section symbol tag.

Beginning The check boxes which are located in part of the dialog box 'Beginning' are used for defining the layout of the intersection line beginning (source). If the **'Show symbol'** check box is on, the symbol which has been defined within the command 'Parameters' will be drawn at the intersection line beginning, otherwise the symbol will not be drawn. The **'Change orientation'** check box will be available for change only when the 'Show symbol' check box is on. This check box is used for copying the placed symbol with respect to the intersection line in order to obtain its mirrored transformation.

End The check boxes which are located in part of the **'End'** dialog box have the same meaning as the previously described check boxes, but these are used for defining the layout of the intersection line end.

Perpendicular text

This check box enables changing the orientation of the section symbol tag. In other words, when this check box is off, the section symbol tag is written in the direction of the intersection line, whereas when the check box is on, the section symbol tag is written at an angle of 90 degrees with respect to the intersection line.

Single-segmented

When this check box is on, the intersection line (source) is drawn without any interruptions, from its beginning to its end. On the other hand, when this check box is off, the intersection line is interrupted so that it does not go across the structure at the place of intersection.

Set as default If the **'Set as default'** check box is on, upon activating the **'OK'** command field, the program will remember the current values of all parameters in the dialog box and use them in its further operation as the default values. Whenever a single data is changed in the dialog box, the program will automatically turn this check box off, so that at every moment you will know whether the contents of the dialog box correspond to the remembered default contents.

If you select several section symbols from the drawing, the program will open the same dialog box as if a single section symbol is selected. However, data which are not equal for all selected section symbols will not be displayed (the check boxes that do not have the same state for all selected symbols will be specially marked). Upon activating the **'OK'** button, only those data which are clearly displayed in the dialog box will be added to all previously selected section symbols, whereas all others (empty and blurred fields) will remain unchanged.

8.3 Editing bolt series

Either by activating the **'Editing bolt series'** command from the **'Metal Studio ► Connecting devices'** drop-down menu or by clicking on the icon , the command bar obtains a new layout:

Select the series by entering the nearest point:

In order to select the series to be edited, you must select from the drawing either a point from one of the bolts belonging to the series or a point from its nearest vicinity. If there are several series at the same distance from the selected point, the program will issue an appropriate warning message and the command bar will obtain a new layout:

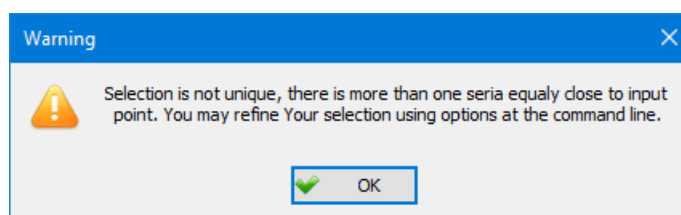

Select one of the series, sorted by depth (1-2) <1>

Upon selecting the series, a dialog box of the following layout will open up:

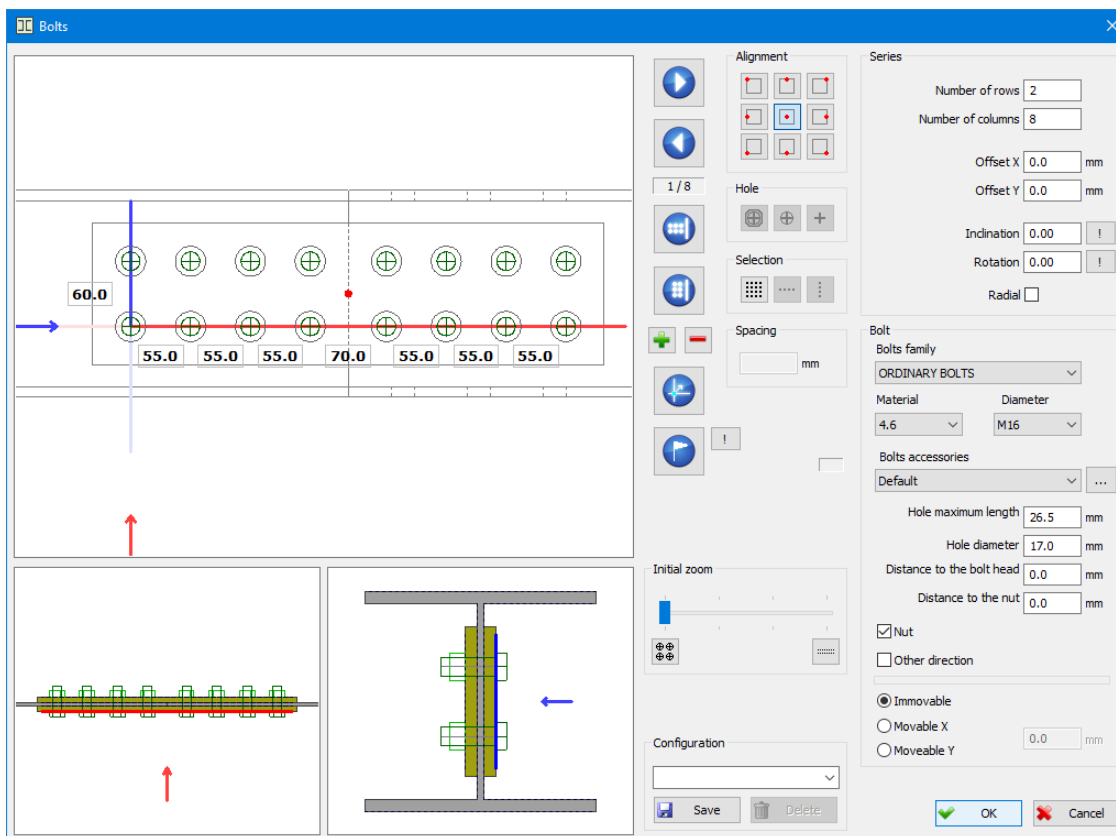

Working with this dialog box is exactly the same as with the dialog box within the 'Bolt series' command.

8.4 Entities alignment

Using this command allows you to align the selected girders and plates spatially, by depth, with other girders and plates. Selecting the '**Entities alignment**', from the '**Metal Studio**' drop-down menu, or by clicking on the icon , a message appears in the command bar, demanding the user to select all the entities, instances of the girders and plates, he/she wants to align:

Selecting the entity being aligned:

Upon selecting the entities being aligned, a reference entity can be chosen, a current girder or a plate, which the selected entity will be aligned by depth with, whereas the command bar obtains the following layout:

Selecting an entity for alignment (Exit) <Exit>:

Choosing an entity for alignment can also be performed subsequently from the dialog box of this command.

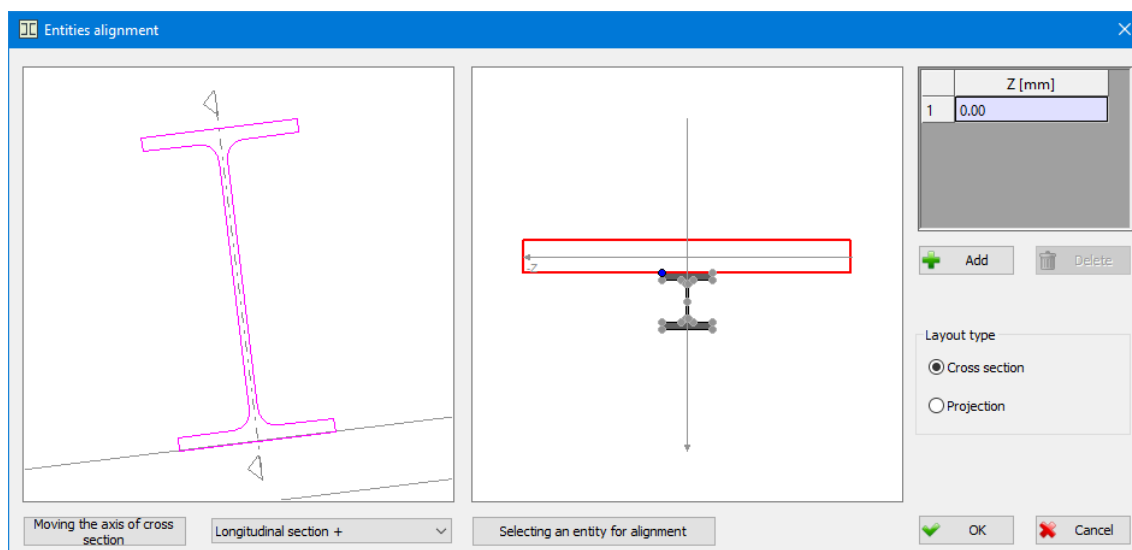

The dialog box for entity alignment by depth - the layout

Entities being aligned, entity for the alignment (reference entity) and the axis of cross section are shown in the left drawing of the dialog box.

Moving the axis of cross section

Since it can quite easily happen that the axis of cross section does not go over the entity for alignment, moving it is also possible. First, you must activate the 'Moving the axis of cross section' button, upon which the axis turns red, and then, by selecting a point from the left drawing, you must define the new position of the axis of cross section.

Selecting the view

The combo box, which is below the left drawing, allows you to select one of the offered cross section planes, as well as its plan view. Its contents depend on the position of the aligned entity in the drawing.

Selecting an entity for alignment

The button whose activation allows you to go to the drawing and chose the new reference entity, which will be used for entity alignment.

Z [mm]

All instances being aligned are displayed in the table in which the current instance is marked with a special color in the drawings in the dialog box. Alignment by depth is performed independently for each of them, either by entering the distance between the instance the instance and the drawing plane into an appropriate field in the 'Z [mm]' column, or by selecting points from the drawing in the right. The latter method will be explained in more detail.

Add

The button whose activation results in inserting a new instance, with the identical geometry and identical numerical data as the instance selected in the moment of inserting, into the first empty spot on the list.

Delete

The button whose activation results in removing the current instance from the table.

Entity alignment by selecting points from the right drawing

In all the intersection points of the contour segments of the entity for alignment, small circles are places. One of the circles is always marked with a special color, which means that this point is currently selected as the reference point for entity alignment. Changing the reference point is performed by moving and

placing the mouse pointer over one of the circles and when it changes its color, you must press the left mouse button. When the mouse pointer is placed over one of the circles in the top left corner of the drawing, the program displays the distance in the direction of the Z axis between it and the reference point. The instance which has been selected in the table is displayed in this drawing in a special color and only it can be aligned with the selected reference point. Alignment is performed by moving and placing the mouse pointer over one of the contour segments of the current instance and when it changes its color, you must press the left mouse button. In addition to contour segments, the instance axis can also be selected for alignment.

Layout type The user is allowed to select the method of viewing in the right part of the dialog box, with the purpose of easier alignment, performed by choosing the points in that drawing.

Cross section – solely the section of the entity in the place of the intersection line displayed in the left drawing, will be displayed in the right drawing.

Projection – solely the section of the entity in the place of the intersection line displayed in the left drawing, with the projection of all the entities on that line, will be displayed in the right drawing.

8.5 Position and assembly change

Using this command enables you to subsequently change both the position number and the assembly position (to which they belong) to the selected entities from the drawing. Either by activating the '**Position and assembly change**' command from the '**Metal Studio**' drop-down menu or by clicking on the icon , the message in which you are requested to select from the drawing an entity whose data you want to change will appear on the command bar.

Selecting objects:

Since you can change both single and multiple data, the program will, upon selecting the first entity, continue to request from the command bar that you select the entity, until you mark the end of the procedure of selecting, either by pressing the 'Enter' key or by right-clicking.

If you have selected only one entity from the drawing, a dialog box of the following layout will open up:

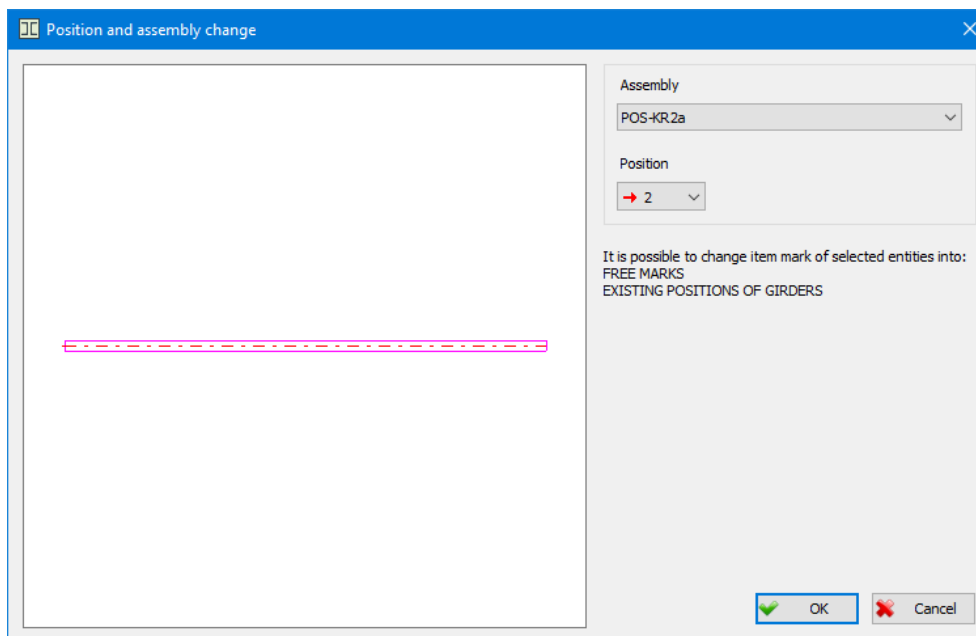

Assembly The combo box for selecting the assembly position into which the selected entity is transferred.

Position The contents of the 'Position' combo box depend on the type of the entity which is selected. Below this box, the program writes (in a message) which position numbers from the selected assembly are included in the box, i.e. into which positions the position number of the selected entity can be changed. Next to the numbers of some positions in this combo box, certain symbols are placed. The '→' symbol denotes the ordinal number of the position to which the selected instance belongs, whereas the '+' symbol denotes the ordinal numbers of all already taken positions. No symbol is placed next to the numbers of all available positions in this combo box.

In case that you select the number of the existing position from the the 'Position' combo box, the dialog box will change its layout.

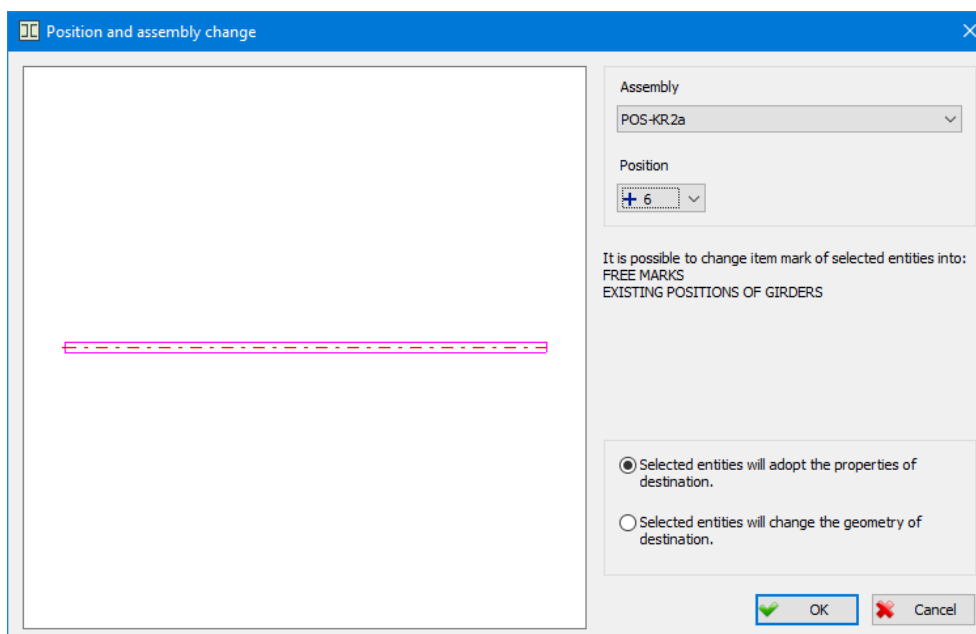

Since the selected entity and the selected position in most cases have different geometry, by selecting one of the two criteria which are now located in the dialog box, you can define, upon the assigned change, whether the entity will assume or change the geometry of the position into which it is being inserted.

Multiple data change

If you select multiple entities from the drawing, the program will open the same dialog box as if a single entity is selected. However, data which are not equal for all the selected entities will not be displayed.

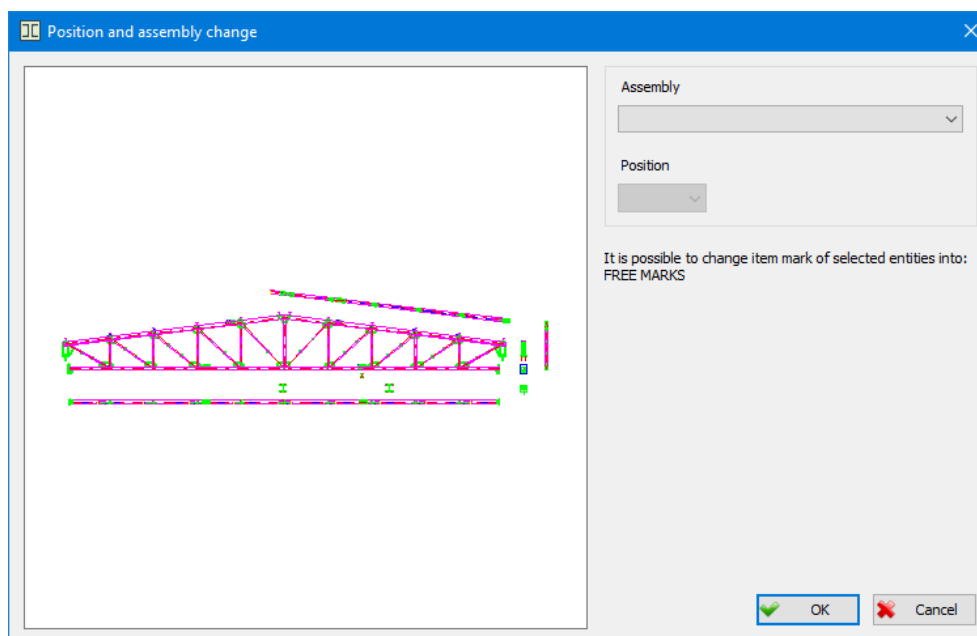

If the selected entities belong to different assembly positions, the 'Position' combo box will remain unavailable for change until you select the desired assembly position from the 'Assembly' combo box.

Since, during changing the position, different rules apply to entities of different types, the contents of the 'Position' combo box now correspond to the contents of the corresponding boxes which could have been obtained by selecting individually every single entity of the given group.

9. ADJUSTING THE ENTITY LAYOUT

9.1 Scale factor change

Since in practice there is quite often a necessity to display certain parts of the drawing in a different scale, we have developed a command which enables you to subsequently change the scale of arbitrarily selected entities from the drawing. In other words, either by selecting the **'Scale factor change'** command from the **'Metal Studio'** drop-down menu, or by clicking on the icon , the message will appear on the command bar in which you are requested to select from the drawing all the entities whose scale you want to change.

Selecting entities for scale factor change:

This message will continue to appear on the command bar until you mark the end of the procedure of selecting either by pressing the 'Enter' key or by right-clicking, upon which the program will request that you specify the point in relation to which the selected objects will be scaled.

Position of the reference point of scaling:

Once you have selected the reference point from the drawing, the program will open the dialog box for setting a new scale.

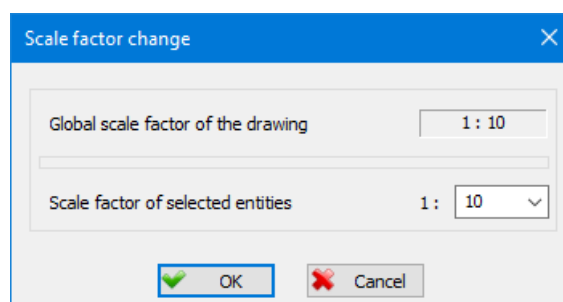

The dialog box for changing the scale factor- the layout

Global scale factor of the drawing

This part of the dialog box contains data on the set main scale which applies to the entire drawing.

Scale factor of selected entities

This edit box displays the current scale of the selected **'Metal Studio'** entities. Changing the scale is performed either by assigning new value in the edit box using the keyboard or by selecting one of the offered scales from the combo box.

Upon activating the **'OK'** button, the dialog box will close and the program will scale all selected elements of the drawing with a factor which will represent either a relative increase or a relative decrease with respect to the main scale of the drawing. During the scaling process, the only thing that the program will not change is the size of the texts. However, it will change their relative position in relation to the scaled elements of the drawing. In this way, all the texts in the drawing, in both scaled and non-scaled parts, will have the same size in the 'AutoCAD' drawing units, which will, for the set main scale, correspond to the assigned size in millimeters on paper when printing.

9.2 Refreshing visibility

Defining the entity edges that are hidden by other entities is a very demanding operation, and therefore, the program does not call it automatically. Using the '**Refreshing visibility**' command enables the user to, at any time, during the work with program, demand the calculation of the hidden edges and drawing of the lines defined for every entity in the dialog box of the 'Parameters' command. Either by selecting this command from the '**Metal Studio**' drop-down menu, or by clicking on the icon , the program will request from the command bar that you choose one of the two options:

Refreshing visibility [Selection/All] <All>:

- All** If this option is chosen, the program calculates the hidden edges of all entities placed in the model.
- Selection** Using this option enables you to demand defining of the hidden edges only in case of the selected entities in the drawing. By choosing this option, the command bar obtains the new layout:

Selection of entities for visibility regeneration

Upon selecting the first entity, the program will still request from the command bar the selection, until you mark the end of the procedure of selecting either by pressing the 'Enter' key or by right-clicking. This will end the command, and the program determines the hidden edges of selected entities and draws them with the lines provided for this.

If the program is in the '3D Modeling' mode, after starting the command the command line looks like this:

Refreshing visibility in all views [Current view/Selection/All] <Selection>:

Given that the program allows working with multiple views, the user chooses whether he wants the refresh to be performed for the current view or for all views at the same time. If the active mode is as shown on the command line, visibility will be refreshed in all views. By selecting the '**Current view**' sub-option, the command line takes on a new form:

Refreshing visibility in current view [all Views/Selection/All] <Selection>:

In this mode of operation the command will refresh the visibility only in the current view.

After selecting the mode of operation of the command, it is necessary to select one of the two options offered from the command line: 'Selection' or 'All'.

9.3 Entity layout

Using the '**Entity layout**' command enables you to change how an entity is displayed in the drawing. Either by activating the command from the '**Metal Studio**' drop-down menu, or by clicking on the icon , the command bar will obtain the following layout:

Selecting objects:

You are now requested to select all entities whose layout you want to change. This message will remain on the command bar until you mark the end of the procedure of selecting either by pressing the 'Enter' key or by right-clicking, upon which the dialog box for adjusting the method of displaying entities in the drawing will open up:

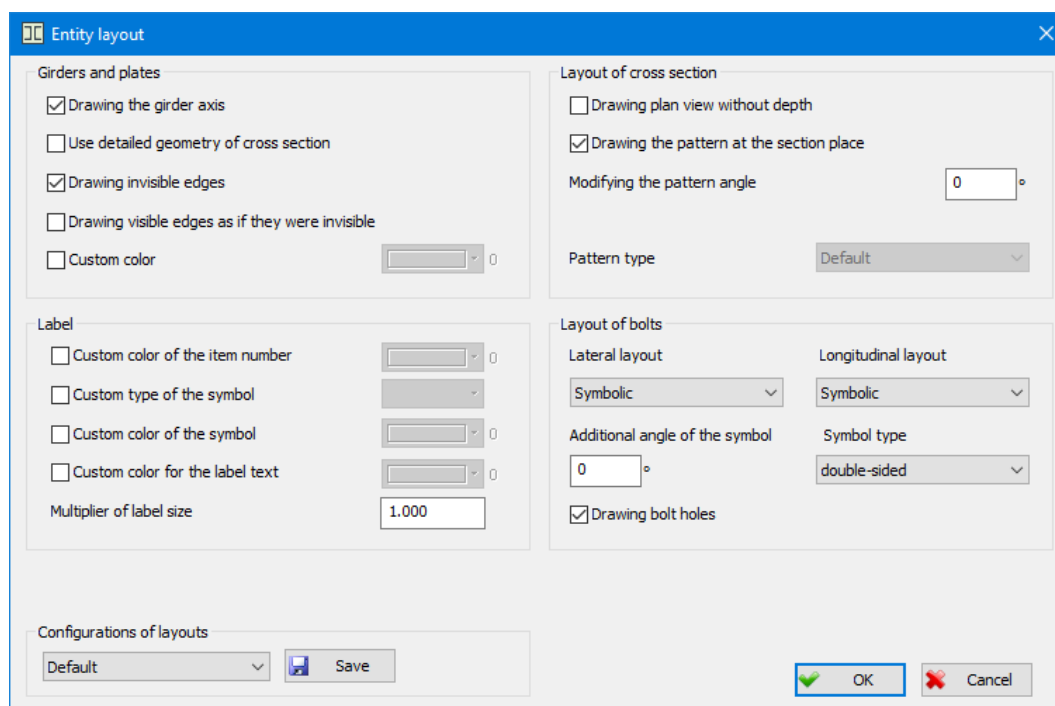

The dialog box for adjusting the method of displaying entities - the layout

Drawing the girder axis

When this check box is on, the girder axis will be displayed, and vice versa, when it is off, the axis will not be drawn on the girder.

Use detailed geometry of cross section

When this check box is on, the girder will be drawn in such a way that a detailed geometry of cross section is used. The detail degree of geometry depends on which method of drawing girder positions has been selected in the 'Functionality' dialog box.

Drawing invisible edges

When this check box is on, entities invisible edges will be displayed with adjustments assigned in the 'Parameters' dialog box, whereas when it is off, entities invisible edges will not be displayed in the drawing at all.

Drawing visible edges as if they were invisible

When this check box is on, entities visible edges will be displayed with adjustments for invisible edges.

Custom color All selected entities can be assigned a completely arbitrary color with which they will be displayed in the drawing. By turning on this check box, a button becomes available, that when activated, opens the color selection dialog.

Label**Custom color of the item number**

All selected entities can be assigned a completely arbitrary color to print the ordinal item number in label. By turning on this check box, a button becomes available, which, when activated, opens the color selection dialog.

Custom type of the symbol

All selected entities can be assigned their own symbol type for writing the ordinal number of the position in label. By activating this check box, a list for choosing one of the offered symbols becomes available.

Custom color of the symbol

All selected entities can be assigned a completely arbitrary color to print the symbol of the ordinal number of the position in label. By turning on this check box, a button becomes available, which, when activated, opens the color selection dialog.

Custom color for the label text

All selected entities can be assigned a completely arbitrary color to print the text in label. By turning on this check box, a button becomes available, which, when activated, opens the color selection dialog.

Multiplier of label size

Edit box in which the coefficient that affects the size of label in the drawing is set. The size of the label can be influenced in two ways. The first one is assigning a coefficient to the entity, which means that all labels with which the entity is labeling after that will be multiplied by the given coefficient, but the labels that were previously set will not change. Another way is to select already set label from the drawing and change their size by entering a coefficient in this edit box.

Layout of cross section

This group contains adjustments which refer only to the method of displaying girder plan view and plate plan view.

Drawing plan view without depth

Upon turning this check box on, you will be able to display without depth the plan views obtained via the command for pursuing cross section with width, which will result in obtaining their simplified layout.

Drawing the pattern at the section place

When this check box is on, girder plan views and plate plan views will be displayed with the pattern, and vice versa, when it is off, the pattern will not be drawn.

Modifying the pattern angle

The edit box for entering the angle by which the pattern will be rotated (the angle positive orientation increases in the anticlockwise direction).

Pattern type Will open up a drop-down menu for selecting one of the pattern types designed by the program.

Layout of bolts

This group contains adjustments which refer only to the method of displaying bolts.

Lateral layout The combo box for selecting a method of displaying bolts in cross section:
Not drawn – the bolt will not be drawn.
Symbolic - the bolt will be represented by a suitable symbol (bolt symbols are located in the file 'SymBolt.dwg').
Realistic with pattern – represents a realistic layout of bolts which is displayed with the pattern.
Realistic without pattern - represents a realistic layout of bolts which is displayed without the pattern.

Additional angle of the symbol

The edit box will be available for changing, solely in case the symbolic layout is chosen as the lateral layout of the bolt. Entering the adequate value, the user is allowed to modify the angle and adjust the position of the bolt symbol in the drawing.

Longitudinal layout

The combo box for selecting a method of displaying bolts in longitudinal section:
Not drawn – the bolt will not be drawn.
Symbolic - the bolt will be represented by a symbol, which can be selected by the user from the list 'Symbol type'.
Realistic with pattern – represents a realistic layout of bolts which is displayed with the pattern.
Realistic without pattern - represents a realistic layout of bolts which is displayed without the pattern.

Symbol type the combo box which becomes active only in case when a symbolic layout of bolts is selected. It enables selecting one of the three bolt symbols in longitudinal section which have been designed by the program: '**axis only**', '**single-sided**', '**double-sided**'.

Drawing bolt holes

When this check box is on, bolt holes will be displayed on an entity. If this check box is off, bolt holes will not be drawn, which is frequently used in case when a bolt is represented by a symbol.

Save

The button upon activating which the configurations of the entities layouts are saved in the database. This is performed so that the state of all parameters defined in this dialog box will be permanently remembered under an arbitrarily assigned name.

The combo box which is located on the left of the 'Save' button contains all previously saved configurations of the entities layouts, thus enabling the user to select any of them at any time.

Activating the '**OK**' button will indicate the acceptance of all actions performed in the dialog box, so that all selected entities in the drawing will be displayed as it has been adjusted in the dialog box, whilst the '**Cancel**' button is intended for quitting.

Drawing arch girders and working with them can take a long time, so the program allows the user to adjust the density of the girder division. If you enter the text '**adens**' from the keyboard, the following message appears in the command bar:

Enter the number of divides for arc girder [10-720] <60>:

The user is now expected to enter the density, or the number of divisions of the circular girder. By default, this value is 60, and by entering the smaller number you decrease the number of divisions and the detail degree of the arch girders, and increase the working speed of the program.

9.4 Configurations of the entities layouts

Either by selecting the '**Configurations of the entities layouts**' command from the '**Metal Studio**' drop-down menu, or by clicking on the icon , the dialog box for adjusting the configurations of entities layout in the drawing will open up:

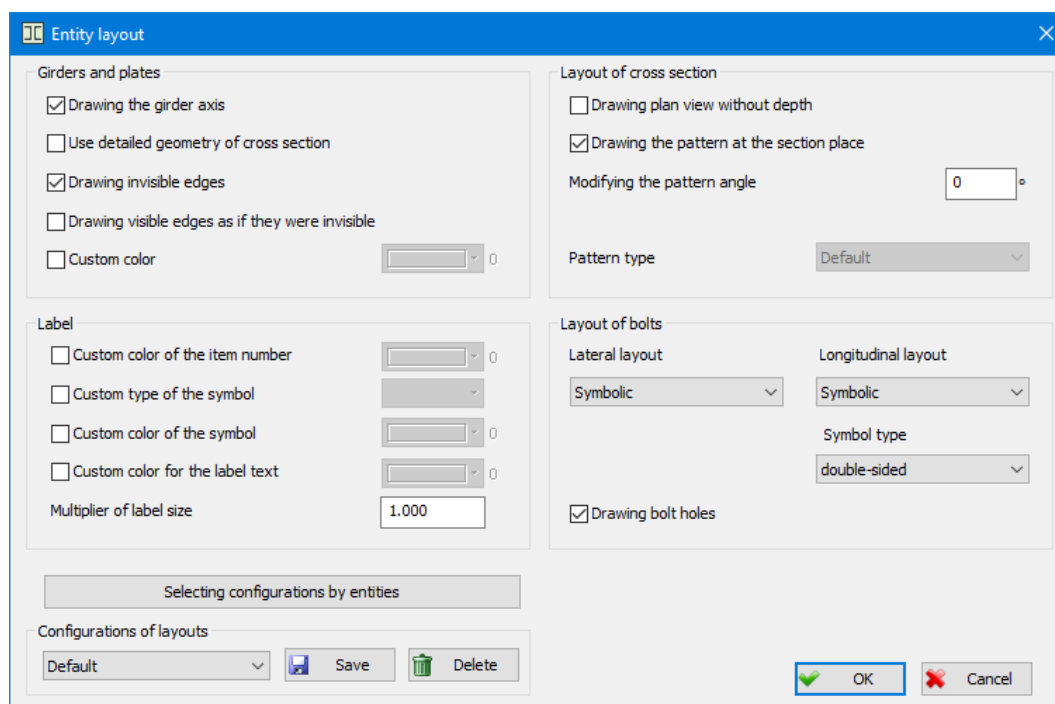

The dialog box for adjusting the configurations of the entities layouts - the layout

This dialog box is identical to the dialog box which opens up when activating the command 'Entity layout', which is the reason why the meaning of certain parameters will not be described here again.

 **Delete** Button upon activating which the currently selected configurations of the entities layouts is deleted from the list.

Selecting configurations by entities

Clicking this button will lead to opening a new dialog box in which it is possible, for each entity, to adjust appropriate configuration of layouts:

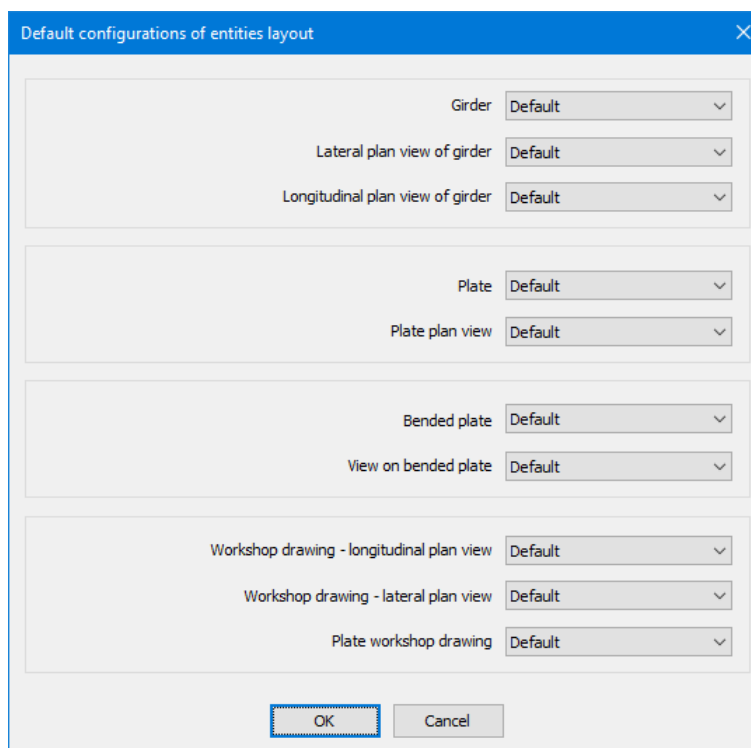

The dialog box for selecting configurations by entities - the layout

Girder

From this combo box, you can select any of the previously defined configurations of the entities layouts. Therefore, all girders which are subsequently drawn will be displayed in the way as defined by the selected configuration.

It is also possible in the same way, for all other entities (lateral plan view of girder, longitudinal plan view of girder, plate, plate plan view, workshop drawing - longitudinal plan view, workshop drawing - lateral plan view and plate workshop drawing) to adjust appropriate configuration of layouts which will be used in further working with the program.

Upon activating the '**OK**' button, the dialog box will close, and all set configurations of layouts for each entity type will be used by the program in its further operation until some other configurations are set by selecting again the 'Configurations of the entities layouts' command.

9.5 Adjusting the visibility of the 'Metal Studio' entities (VISIBILITY)

Using the '**Visibility**' command enables you to selectively set and cancel visibility to entities located in the drawing. Either by selecting the command from the '**Metal Studio**' drop-down menu, or by clicking on the icon , the dialog box of the following layout will open up:

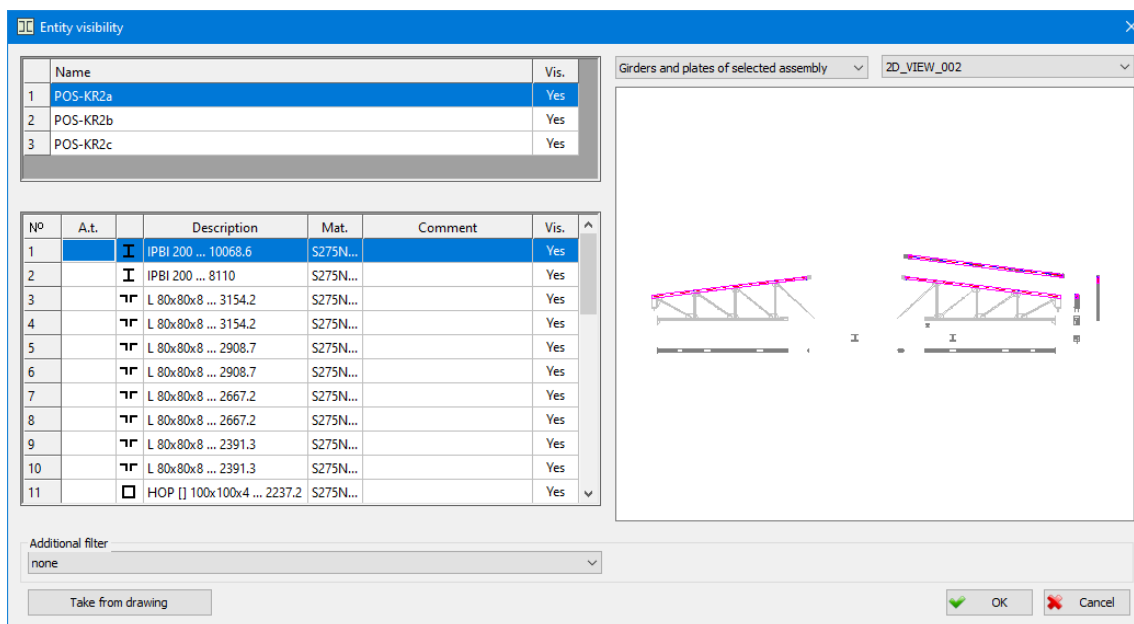

The dialog box within the 'Visibility' command - the layout

The top left part of the dialog box displays a list containing all assembly positions which have been added to the current drawing.

Vis. An indicator indicating whether a given assembly position is visible or not. By right-clicking on this indicator, it will alternately gain a positive i.e. a negative response. In other words, right-clicking on this indicator leads to setting the opposite value which relates to the assembly position displayed within the given row. If multiple assembly positions are selected from the list, right-clicking on any indicator in the list will result in changing the indicator value of all selected assembly positions. Furthermore, right-clicking on the 'Vis.' column name will result in changing the indicator value of all assembly positions in the list.

In the bottom left part of the dialog box, there is a list displaying all girder and plate positions belonging to the selected assembly position from the upper list. The meaning of each column in the list is the same as in the 'Database of positions' command.

Vis. An indicator indicating whether a given girder or plate position is visible or not. The procedure intended for setting or cancelling visibility in this list is the same as in assembly positions. Please note that the criterion for setting visibility by assembly positions, in the order of precedence, comes before the criterion for setting visibility by certain girder or plate positions. In other words, if it has been set for an assembly position to be invisible, the program will set all girder and plate positions belonging to it as invisible, regardless of what has been assigned for this parameter within the entities list. Setting visibility selectively for girder and plate positions will make sense only if the assembly position to which they belong has been set as visible.

In the right part of the dialog box, there is a window intended for displaying girder and plate positions. By selecting from the combo box above the window, you can set one of the three types of layout as the current one: **'Position geometry'**, **'Girders and plates of the selected assembly'** and **'All girders and plates'**.

If you are in the '3D modeling' operating mode, and the display of elements from the current assembly or all elements is selected from the list, a list will become available from which it is possible to select one of the views that are set in the views. Then the position of the position instances in the selected view will be displayed in the window.

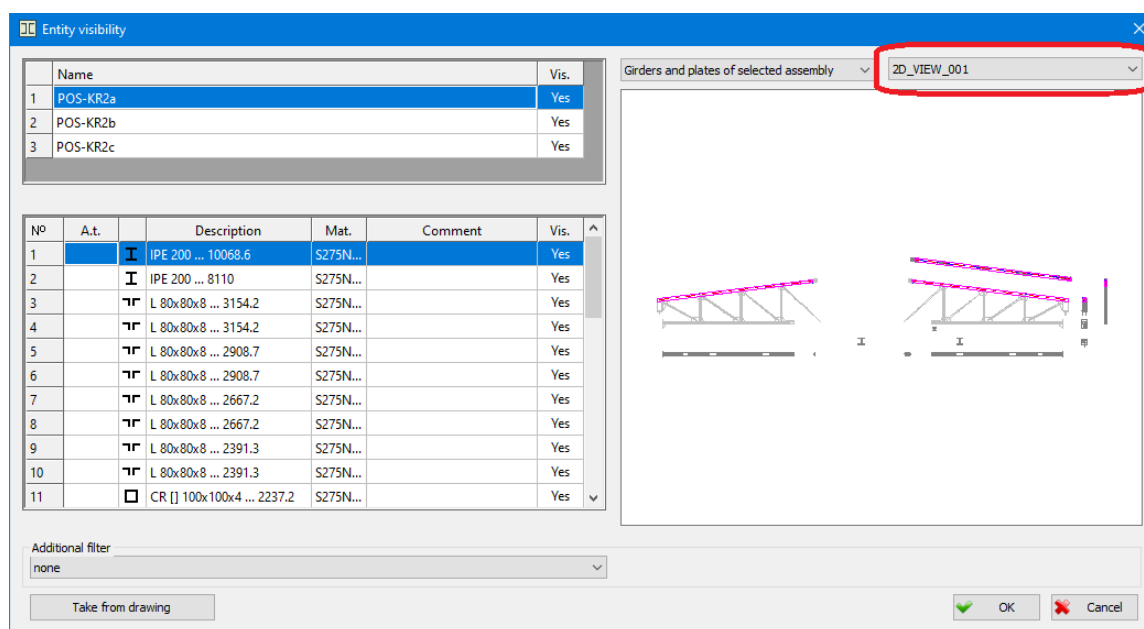

A list of view names that are set in viewports

It should be pointed out here that, the selected layout of entity positions does not represent the preview of the state in the drawing which will be obtained upon exiting the dialog box, but its purpose is merely to facilitate selecting the desired girder or plate position from the list. Therefore, the selected entity layout will always look the same in the dialog box regardless of the current state of visibility in the dialog box.

Additional filter

The combo box which contains filters designed by the program for the diagnostics in the drawing. The filters will have an effect only on girder or plate positions which have been set as visible in the list.

none - The program will set as visible all girder or plate positions in which the 'Yes' indicator has been set without any additional criteria.

Only instances which will be included in the specification - All girder and plate instances, in which the 'Specification' check box is on and total quantity other than zero, will be displayed in the drawing.

Only instances which will not be included in the specification - Using this filter enables you to obtain a useful piece of information, as to which entities are present in the drawing and yet do not take any part in the total quantity of the given position during generating the specification. From this it follows that, all those entities whose 'Specification' check box has been turned off during creating will be visible. In this way, you can easily spot mistakes if there are any.

Only instances of positions with workshop drawings - All girder and plate instances for which workshop drawings have been generated will be displayed in the drawing.

Only instances of positions without workshop drawings - All girder and plate instances for which workshop drawings have not been generated will be displayed in the drawing.

Only instances from positions of girders longer than - When this filter is selected, the program will set as visible all instances which are longer than the assigned length in the edit box, which appears now in the continuation of the combo box.

Only positions of the selected shape - When this filter is selected, two new combo boxes will appear in the dialog box. These boxes are intended for selecting the type of cross section and the type of shape. The program will set as visible only those positions which have been created from the selected section.

Girders - All the material instances of the girders will be displayed in the drawing.

Plan view of girder - All the immaterial instances of the girders will be displayed in the drawing.

Plates - All the material instances of the plates will be displayed in the drawing.

Plan view of plates - All the immaterial instances of the plates will be displayed in the drawing.

Take from drawing - Clicking on this button opens the drawing to select an entity (girders or plates) whose assembly and position will be set as current when returning to the dialog.

Upon activating the **'OK'** button, the program will modify the state of the drawing so that it completely corresponds to the parameters set in this dialog box.

9.6 Switching 2D and 3D views

Depending on the user requirements, the program allows switching from the 2D into the 3D layout, and vice versa, either by selecting the **'Switching 2D and 3D views'** command, from the **'Metal Studio'** drop-down menu or by clicking on the icon .

It is necessary to emphasize that there is no difference between the drawing of the model and the drawing of the pursued cross sections and details in the 2D layout, while the 3D layout clearly shows which instances are material, and which are not.

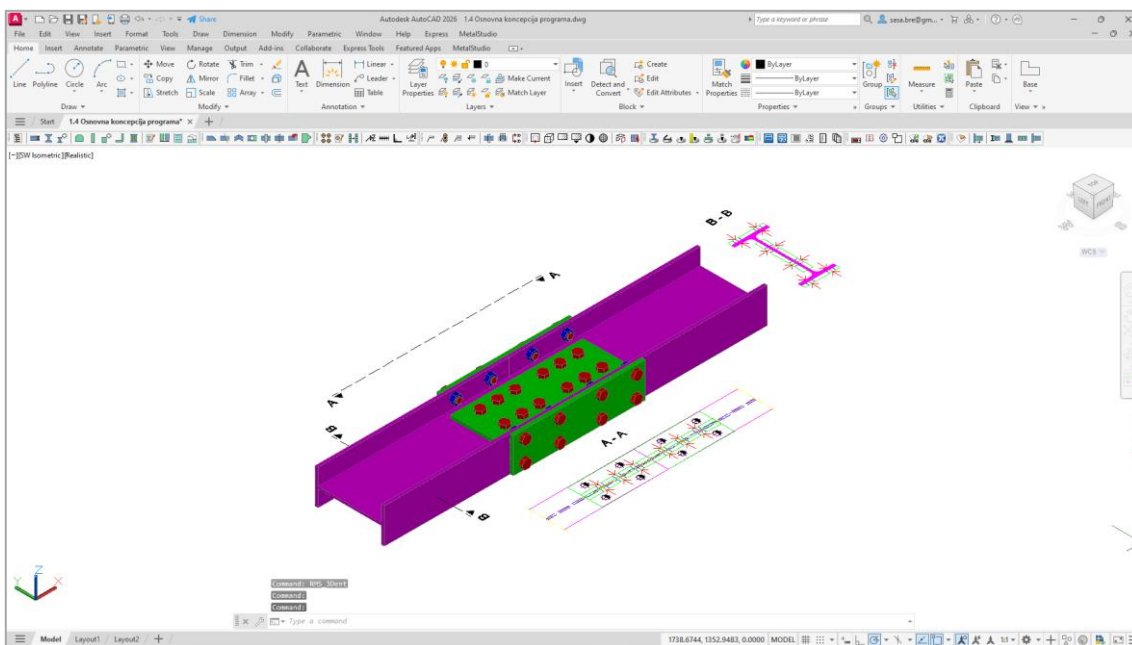

Drawing in the 3D layout – realistic 3D entity model

Selecting again the 'Switching 2D and 3D views' command results in switching to the 2D layout:

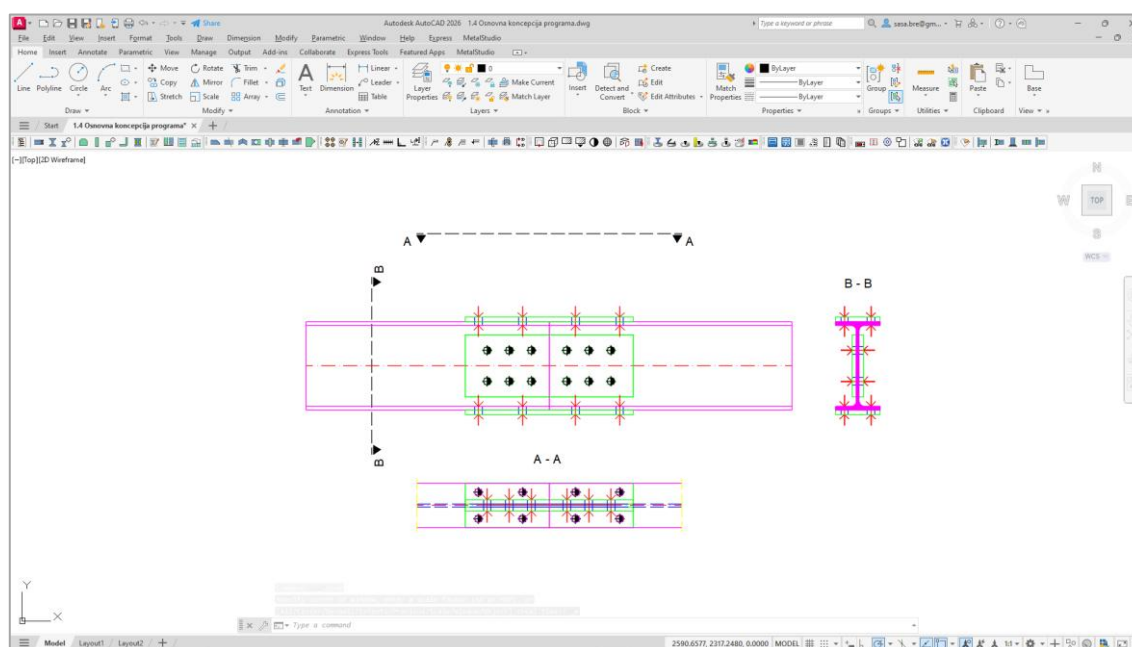

Drawing in the 2D layout – 2D model

Please note that this command will not be available when the program is in the '3D Modeling' mode.

9.7 Drawing frame

Using the '**Drawing frame**' command allows you to place the frame on the drawing, representing the dimensions of the paper you want to print the drawing on. Either by selecting this command from the '**Metal Studio**' drop-down menu or by clicking on the icon , the following dialog box will open up:

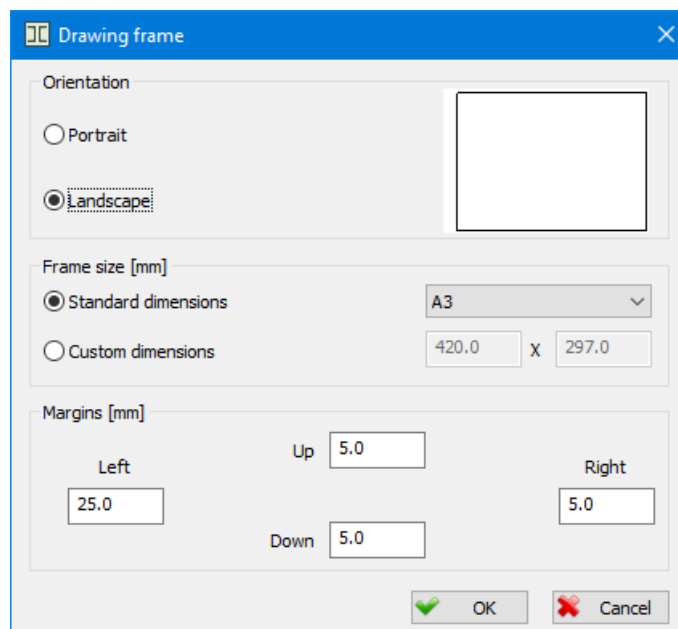

The dialog box for placing the frame - the layout

Orientation

This part of the dialog box contains the switches that are used for the purpose of adjusting the frame orientation, and on their right, there is a graphical display of the paper, with the corresponding dimensions, orientation and the margins.

Portrait The switch whose activation results in the vertical orientation of the frame.

Landscape The switch whose activation results in the horizontal orientation of the frame.

Frame size [mm]

This part of the dialog box contains the switches for defining the frame dimensions.

Standard dimensions

The switch whose activation from the combo box to its right results in the possibility of choosing one of the given standard paper formats (A0 to A10, B0 to B10, C0 to C10).

Custom dimensions

The switch whose activation results in the possibility of assigning completely arbitrary paper dimensions in the appropriate edit boxes.

Margins [mm]

This part of the dialog box contains four edit boxes for defining the spacing from the edges of the frame, where the program draws the margins. If the entered value in some of these edit boxes equals zero, that margin will not be drawn.

- Top** The edit box for entering the size of the upper margin.
- Bottom** The edit box for entering the size of the bottom margin.
- Left** The edit box for entering the size of the left margin.
- Right** The edit box for entering the size of the right margin.

Activating the **'OK'** button will result in closing the dialog box and starting the procedure of placing the frame around the drawing, demanding the user to specify the point he/she wants to place the bottom left part of the frame in.

Position of the frame:

The actual size of the frame in the drawing is defined on the basis of the chosen format and the current scale of the drawing. The number of the frames placed in one drawing is not limited.

10. CREATING DATABASES USED BY THE PROGRAM IN ITS OPERATION

10.1 Database of shapes

Selecting the '**Database of shapes**' command will result in opening the dialog box for editing the database of shapes which is delivered with the program.

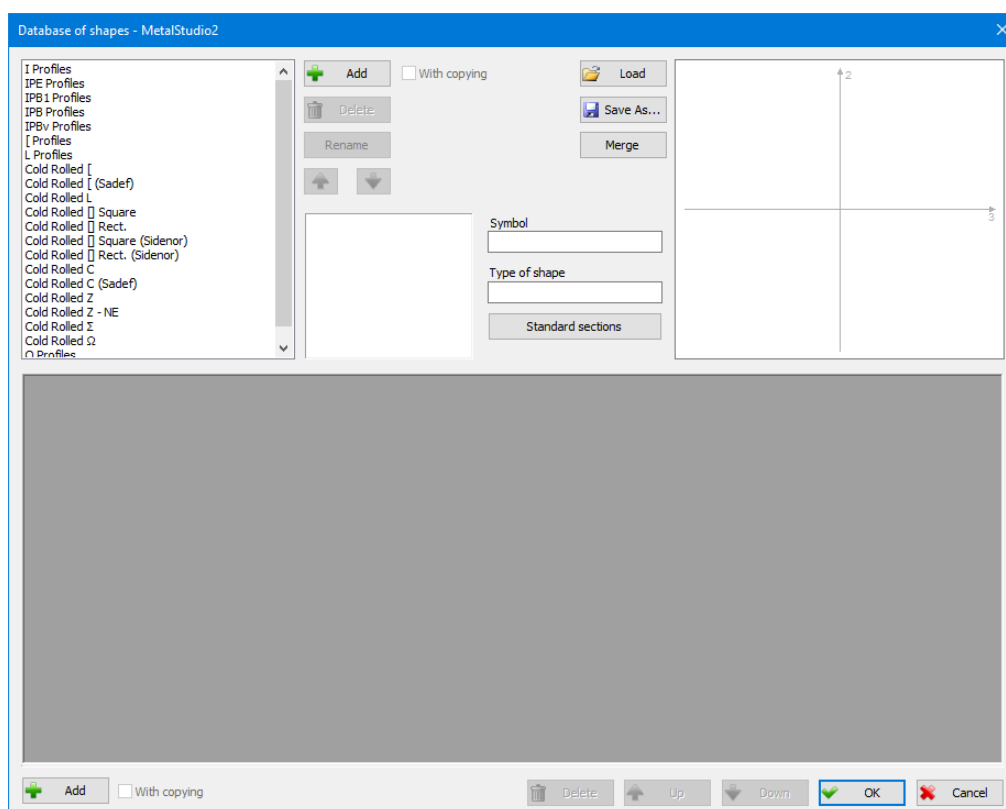

Three databases of shapes are delivered with the program, MetalStudio2.\$prf, MetalStudio2_UPE.\$prf and MetalStudio2_GOST.\$prf. Since there can be several databases of shapes, the name of the currently active database is written in the header of this dialog box.

 **Save as** Saving the current database of shapes under a new name.

 **Load** Loading one of the previously created databases of shapes.

Merge The button for merging two databases of shapes, i.e. for entering all the profiles from some database in a database that is currently active. By selecting it, the dialog box for choosing the database of shapes, that will be merged with the currently active database, opens up.

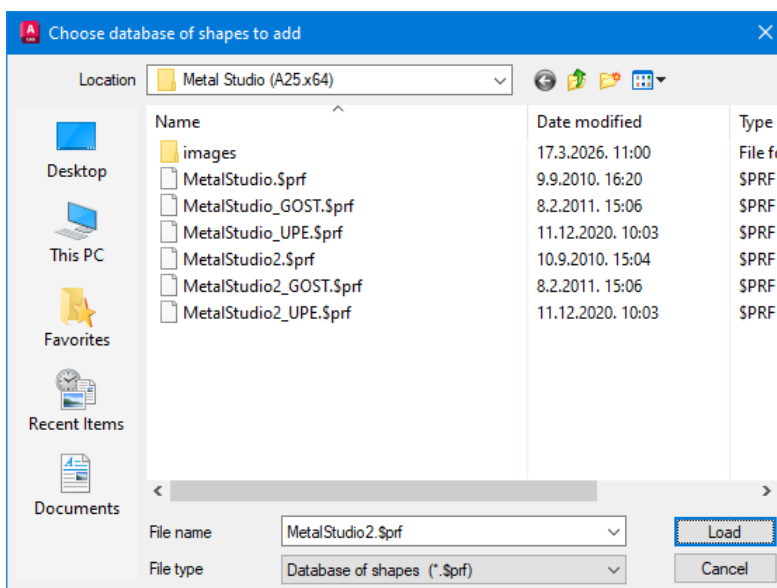

Upon choosing the database from the list, the button '**Load**' must be pressed, which opens up the dialog box for selecting the style of adding the shapes in the current database.

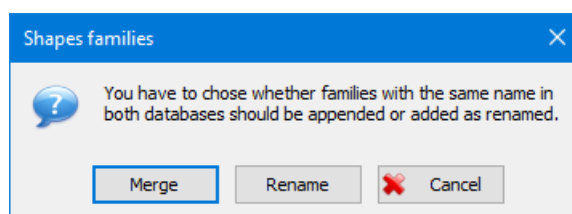

For the shape families with identical name in both databases, one of two provided styles can be chosen:

Merge – By choosing this button, shapes are entered in the family of the same name, in the currently active database.

Rename – By choosing this button, the program will enter and rename the shape family, with identical name as some family in the current database, in the current database.

The top left corner of the dialog box displays a list of all types of shapes existing in the currently active database. Upon selecting one of them, a table with numerical data on all shapes of the selected type will appear in the lower part of the dialog box.

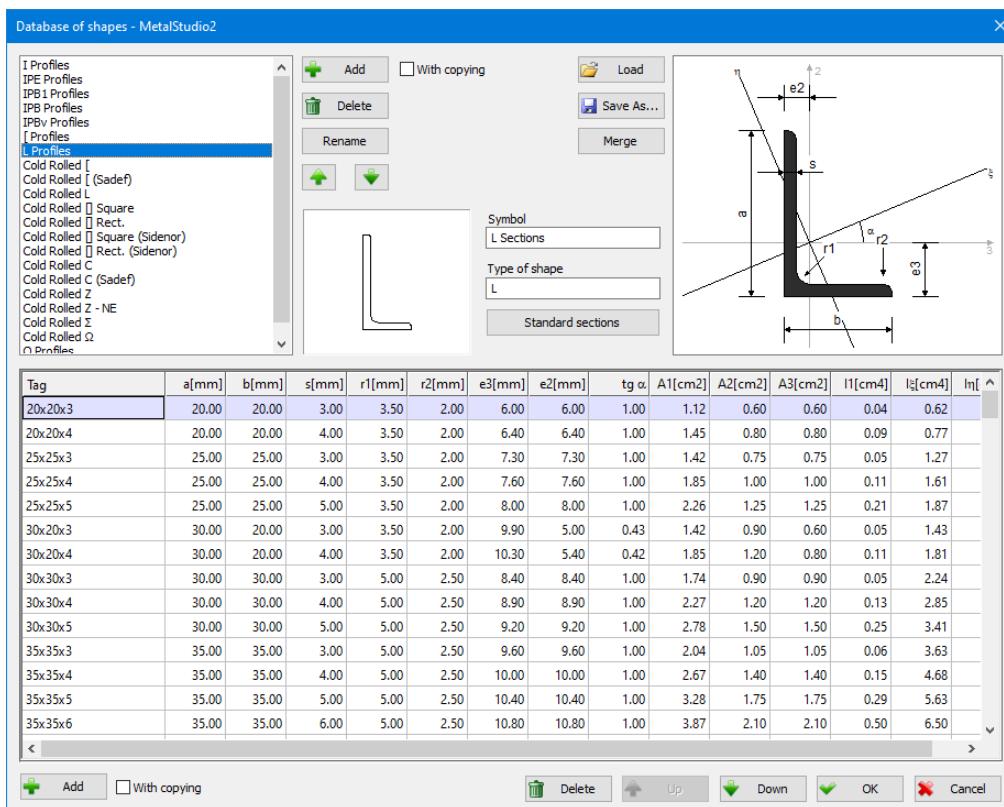

Each shape is defined by its tag and multiple numerical data assigned in appropriate columns. In the header of each column, there is a datum tag and a unit of measurement with which it is expressed is written between parentheses. In order to make the meaning of data related to the shapes dimensions clearer, in the top right corner of the dialog box, all required values for the given shape are labeled schematically. Since the quantity of numerical data defining a shape can be quite large, it may happen that not all columns can be simultaneously displayed in the dialog box. In such a case, a horizontal scroll bar will appear at the bottom of the list, using which any column from the table can be displayed.

Using a group of buttons located in the lower part of the dialog box enables arranging the table of shapes for each selected type from the list.

Add The button upon activating which a new shape is inserted in the table. If the **'With copying'** check box is on, by pressing this button, a copy of the currently selected shape will be inserted in the table.

Delete The button upon activating which the currently selected shape is deleted from the table.

Up The button upon activating which the position of the currently selected shape is changed by moving one row up in the table.

Down The button upon activating which the position of the currently selected shape is changed by moving one row down in the table.

In addition to the possibility of arranging the table for each type of shapes from the list, it is also possible to edit the list of types of shapes. For this purpose, buttons which are located on the right of the list of types of shapes have been intended.

Pressing the  **Add** button will lead to opening a dialog box for defining the name and type of the shape which will be added to the database of shapes.

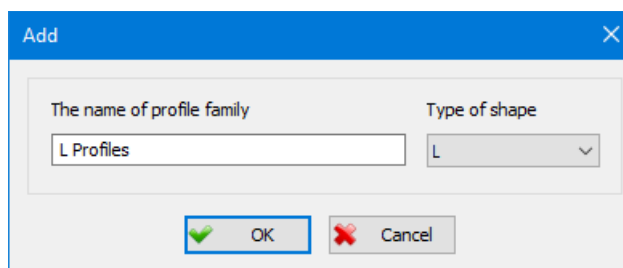



A name of the group of shapes can be assigned completely arbitrarily, under the condition that it does not already exist in the list, whereas selecting a type of shape is performed from the combo box. Upon clicking the **OK** button, the program will return to the basic dialog box for editing database of shapes, and a new group of shapes is inserted at the end of the list.

If the **'With copying'** check box is on, the currently selected type of shape is copied via the  **Add** button in the list under a new name. Pressing this button opens the same dialog box as when the check box is off. However, now it is possible to change in it only the name of the group of shapes.

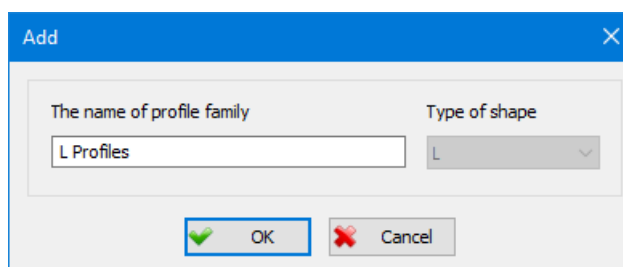
'Rename' – Upon clicking this button, the dialog box where the name of the shape group selected from the list can be changed opens up.



New name is entered in the edit box **'The name of profile family'**. Upon clicking the **OK** button, the program will return to the basic dialog box for editing database of shapes, and the shape group is now displayed with the new name.

The purpose of the  **Delete**,  **Up** and  **Down** command fields is the same as when working with the table of shapes, but now they are related to arranging the list of types of shapes.

Symbol

In this edit box, the symbol name which will be displayed in the label of all shapes of the given type can be added to each type of shape. The layout of the assigned symbol is displayed in the window on the left of this edit box. These symbols are created in the same way as the AutoCAD blocks and are saved in the 'SymDim.dwg' database of configurations. Working with symbols and the AutoCAD blocks has been described in the chapter 'Symbols used in the program'.

Type of shape In this edit box, an arbitrary description which will be written in the label of all shapes of the given type can be added to each type of shape, if displaying it has been assigned in the current labeling style.

Upon pressing the **'Standard sections'** button, a new dialog box of the following layout will open up:

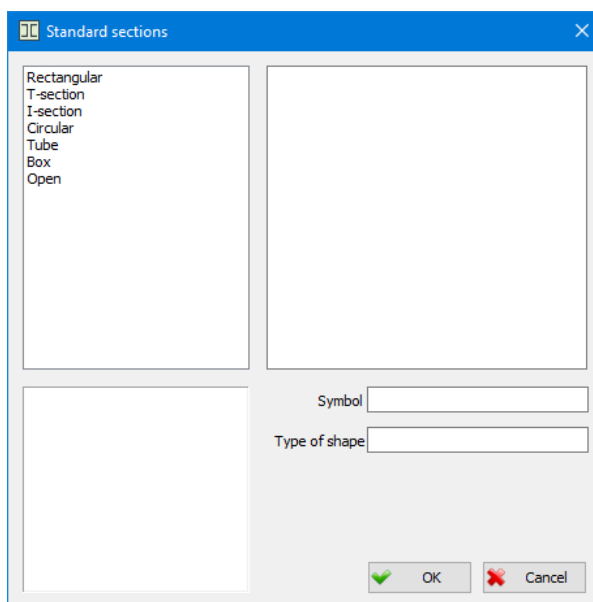

The top left corner of the dialog box displays a list of all standard sections designed by the program. Upon selecting one of them, the picture of it with schematically labeled dimensions will appear in the right part of the dialog box.

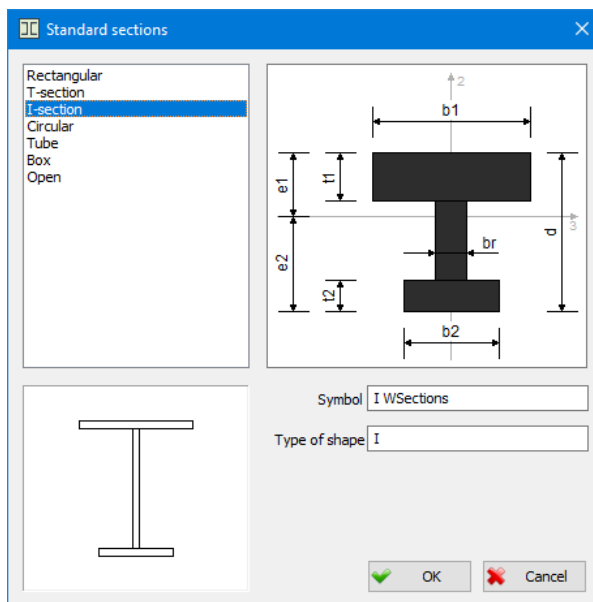

Symbol

In this edit box, the symbol name which will be displayed in the label can be added to each standard section. The layout of the assigned symbol is displayed in the window which is located in the bottom left corner of the dialog box. These symbols are created in the same way as the AutoCAD blocks and are saved in the appropriate database of configurations. Working with symbols and the AutoCAD blocks has been described in the chapter 'Symbols used in the program'.

Type of shape

In this edit box, an arbitrary description which will be written in the label can be added to each standard section, if displaying it has been assigned in the current labeling style.

10.2 Database of bolts

Selecting the '**Database of bolts**' command will result in opening the dialog box for editing the database of bolts which comes delivered with the program.

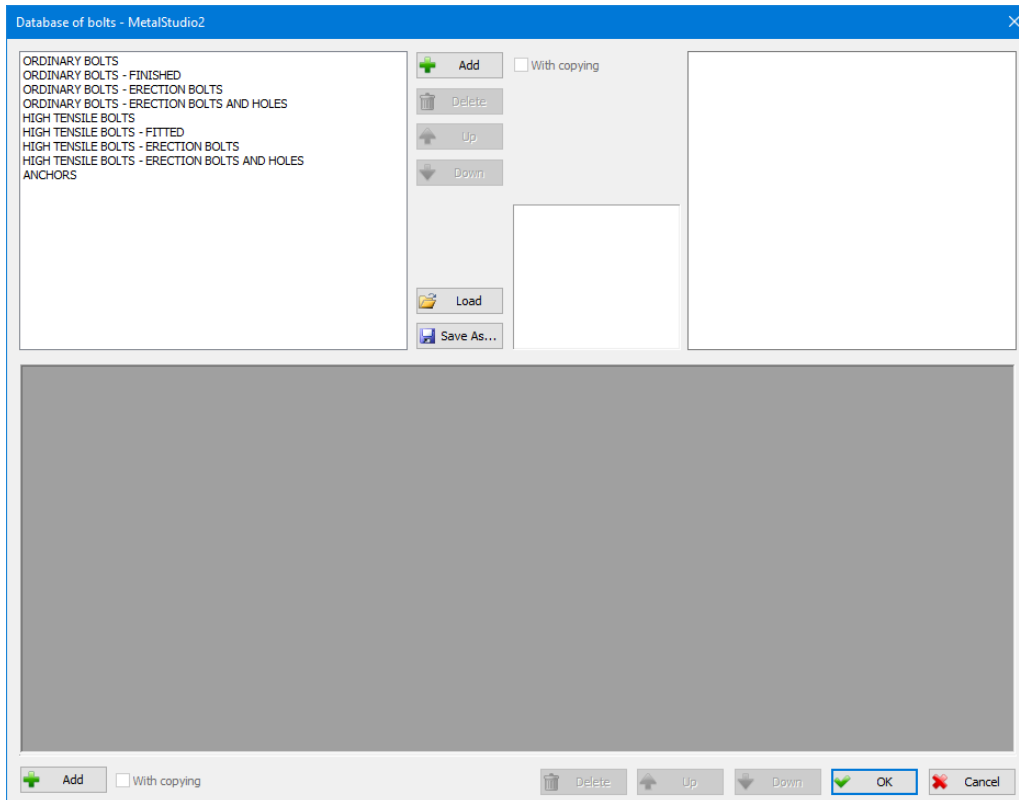

Since there can be several databases of bolts, the name of the currently active database is written in the header of this dialog box.

 **Save as** Saving the current database of bolts under a new name.

 **Load** Loading one of the previously created databases of bolts.

The top left corner of the dialog box displays a list of all bolt families existing in the currently active database. Upon selecting one of them, a table with numerical data on all bolts of the selected family will appear in the lower part of the dialog box.

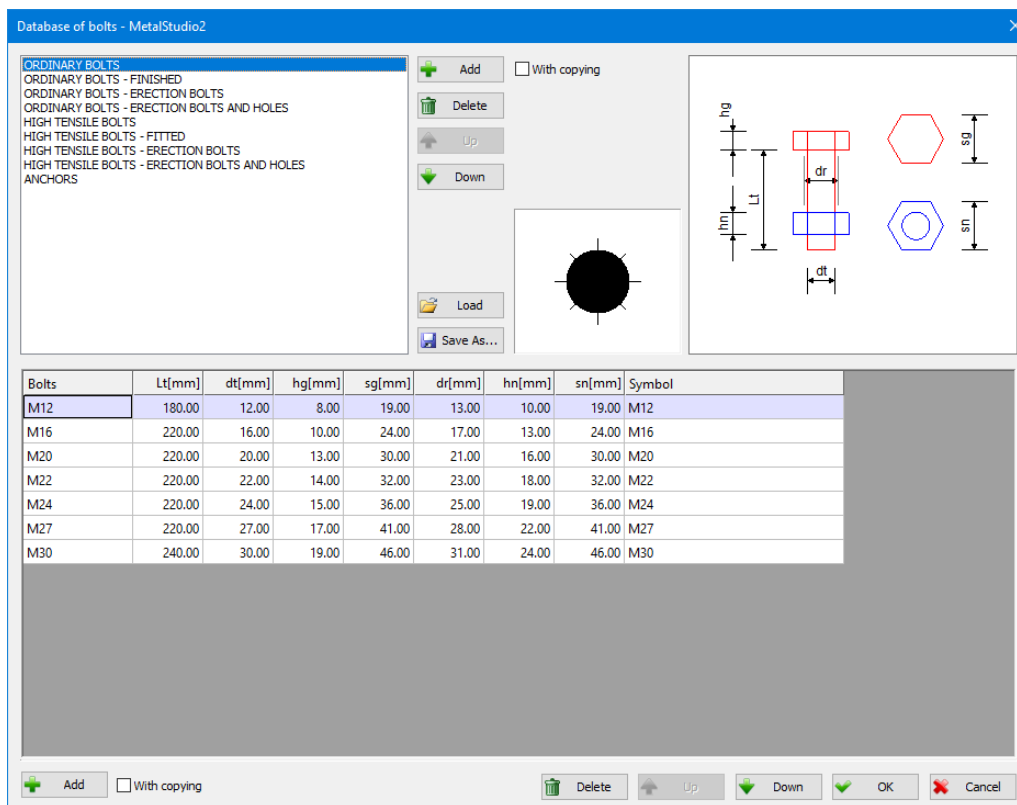

Each bolt is defined by its tag and multiple numerical data assigned in appropriate columns. In the header of each column, there is a datum tag and a unit of measurement with which it is expressed is written between parentheses. In order to make the meaning of data related to the bolt dimensions clearer, in the top right corner of the dialog box, all required values for the given bolt are labeled schematically.

Bolts Bolt tag.

Lt [mm] Maximum length of the bolt body. This datum is not used for now.

dt [mm] Diameter of the bolt body.

hg [mm] Height of the bolt head.

sg [mm] Diameter of the circle written in the bolt head.

dr [mm] Diameter of the hole through which the bolt goes.

hn [mm] Height of the nut.

sn [mm] Diameter of the circle written in the nut.

Symbol In this column, you can add to each bolt the symbol name which will be displayed in the drawing instead of the bolt when the symbolic layout of bolts in longitudinal section has been selected. The layout of the assigned symbol is displayed in the window which is located in the middle of the dialog box. These symbols are created in the same way as the AutoCAD blocks and are saved in the 'SymBolt.dwg' database of configurations. Working with symbols and the AutoCAD blocks has been described in the chapter 'Symbols used in the program'.

Using a group of buttons located in the lower part of the dialog box enables arranging the table of bolts for each selected type from the list.

 **Add** The button upon activating which a new bolt is inserted in the table. If the '**With copying**' check box is on, by pressing this button, a copy of the currently selected bolt will be inserted in the table.

 **Delete** The button upon activating which the currently selected bolt is deleted from the table.

 **Up** The button upon activating which the position of the currently selected bolt is changed by moving one row up in the table.

 **Down** The button upon activating which the position of the currently selected bolt is changed by moving one row down in the table.

In addition to the possibility of arranging the table for each family of bolts from the list, it is also possible to edit the list of families of bolts. For this purpose, buttons which are located on the right of the list have been intended.

Pressing the ' **Add**' button will lead to opening a dialog box for defining the name and type of the family of bolts which will be added to the database.

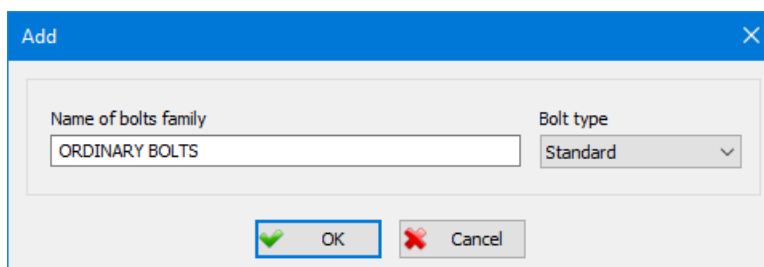

A name of the family of bolts can be assigned completely arbitrarily, under the condition that it does not already exist in the list, whereas selecting a type of bolt is performed from the combo box. Upon clicking the '**OK**' button, the program will return to the basic dialog box for editing the database of bolts, and a new family of bolts is inserted at the end of the list.

If the '**With copying**' check box is on, the currently selected family of bolts is copied via the ' **Add**' button in the list under a new name. Pressing this button opens the same dialog box as when the check box is off. However, now it is possible to change in it only the name of the family of bolts.

The purpose of the ' **Delete**', ' **Up**' and ' **Down**' command fields is the same as when working with the table of bolts, but now they are related to arranging the list of families of bolts.

10.3 Database of predefined bolt lengths

Selecting the '**Database of predefined bolt lengths**' command will result in opening the dialog box for editing the database of bolt lengths which comes delivered with the program.

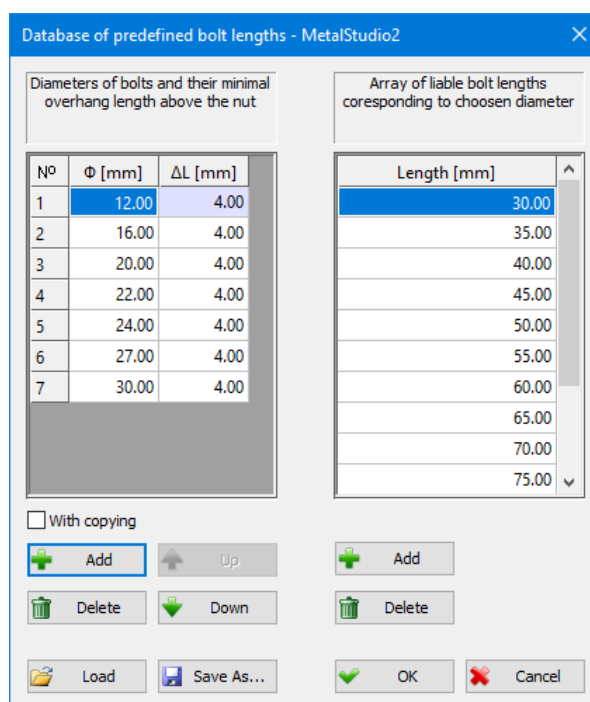

In this dialog box, the user is allowed to define the minimum overhang lengths and bolt lengths. This will result in program automatically assigning the required bolt lengths taking into account the thickness of the elements being joint, and the available bolt lengths entered into the database of bolt lengths.

Φ [mm] Diameters of the bolt body.

ΔL [mm] Minimum lengths of the overhang above the nut, for the specific diameter of the bolt.

Length [mm] The list of the possible bolt lengths for the chosen diameter of the bolt.



Using a group of buttons, located below the left table where the minimum overhang lengths are defined, enables arranging the table.

 **Add** Inserting a new row in the table. If the '**With copy**' check box is on, by pressing this button, a copy of the currently selected row will be inserted in the table.

 **Delete** Deleting the currently selected row from the table.

 **Up** Moving the currently selected row one row up in the table.

 **Down** Moving the currently selected bolt one row down in the table.

The purpose of the ' **Add**', ' **Delete**' command fields, located below the left table, is the same as when working with the left table, but now they are related to arranging the list of the possible bolt lengths for the chosen diameter in the left table.

 **Save as** Saving the current database of bolt lengths under a new name.

 **Load** Loading one of the previously created databases of bolt lengths.

10.4 Database of structure materials

Selecting this command will result in opening the dialog box for editing the database of structure materials which comes delivered with the program.

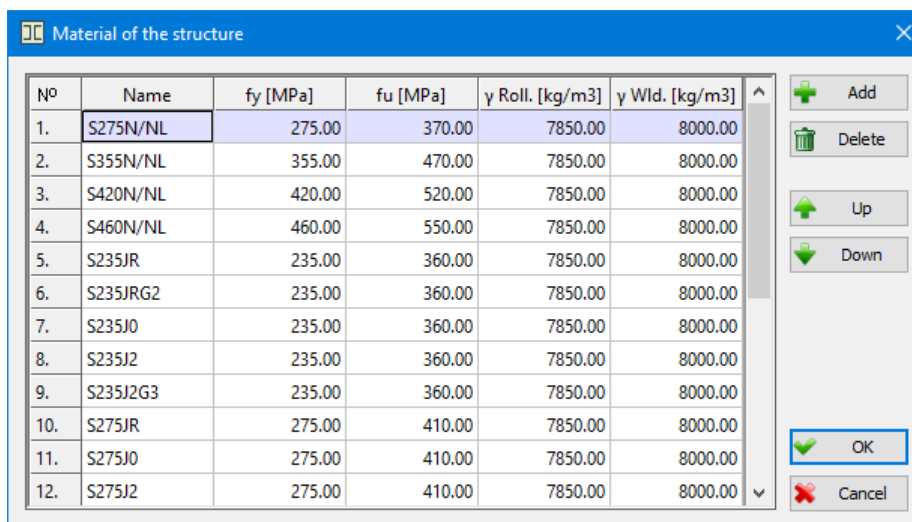

N°	Name	fy [MPa]	fu [MPa]	γ Roll. [kg/m3]	γ Wld. [kg/m3]
1.	S275N/NL	275.00	370.00	7850.00	8000.00
2.	S355N/NL	355.00	470.00	7850.00	8000.00
3.	S420N/NL	420.00	520.00	7850.00	8000.00
4.	S460N/NL	460.00	550.00	7850.00	8000.00
5.	S235JR	235.00	360.00	7850.00	8000.00
6.	S235JRG2	235.00	360.00	7850.00	8000.00
7.	S235J0	235.00	360.00	7850.00	8000.00
8.	S235J2	235.00	360.00	7850.00	8000.00
9.	S235J2G3	235.00	360.00	7850.00	8000.00
10.	S275JR	275.00	410.00	7850.00	8000.00
11.	S275J0	275.00	410.00	7850.00	8000.00
12.	S275J2	275.00	410.00	7850.00	8000.00

All steel types which are located in the database are displayed in the table.

Name Steel type.

fy [MPa] Value of the yield strength for the specific steel type.

fu [MPa] Value of the tensile strength for the specific steel type.

γ Roll. [kg/m3]
Specific weight of the steel for the rolled and hot-rolled shapes.

γ Wld. [kg/m3]
Specific weight of the steel for the plates and cold-rolled shapes.

The purpose of the , ,  **Up** and  **Down** command fields is the same as when working with tables in the previously described commands.

10.5 Database of bolt materials

Selecting this command will result in opening the dialog box for editing the database of bolt materials which comes delivered with the program.

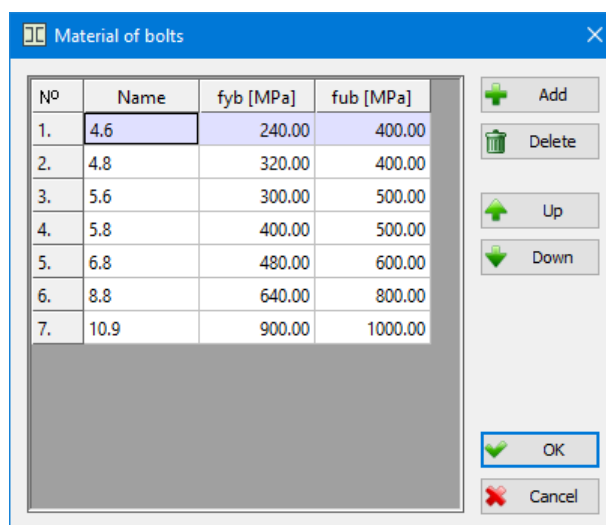

All steel types which are located in the database are displayed in the table.

Name Steel type.

fyb [MPa] Value of the yield strength for the specific steel type.

fub [MPa] Value of the tensile strength for the specific steel type.

The purpose of the 'Add', 'Delete', 'Up' and 'Down' command fields is the same as when working with tables in the previously described commands.

10.6 Database of arbitrary cross sections

In the 'Metal Studio' program it is possible to define the cross sections of arbitrary geometry. Geometry of arbitrary cross sections is defined by drawing some of the AutoCAD commands for line drawing, while it is necessary that the contour being assigned is closed.

In order to use the created cross section, it is necessary that it is entered in the database of arbitrary cross sections. Either by activating the '**Database of arbitrary cross sections**' from the '**Metal Studio ► Materials and shapes**' drop down menu, or by clicking on the icon , the following dialog box will open up:

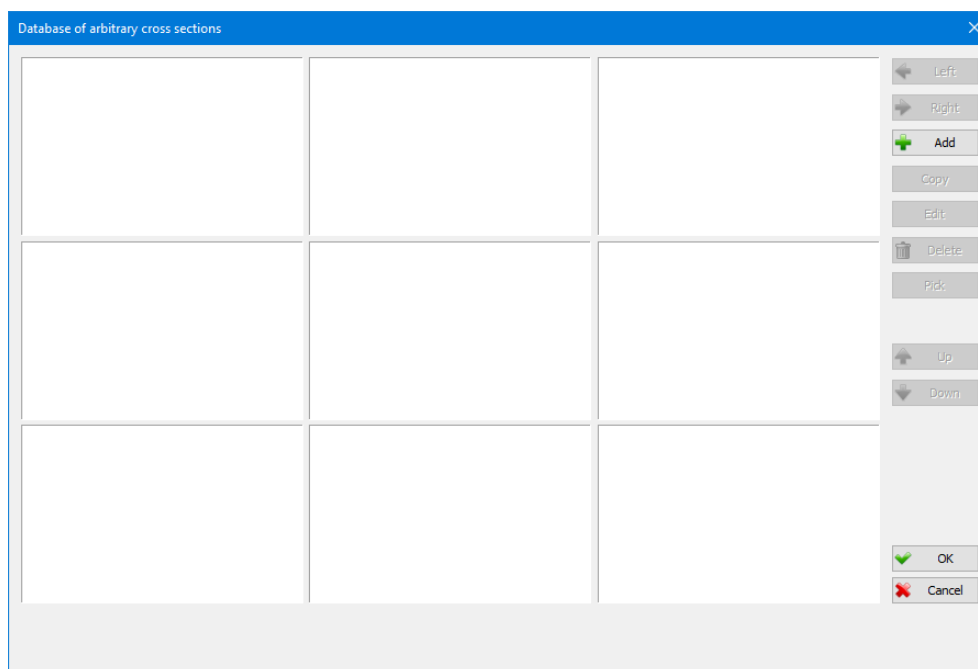

The dialog box 'Database of arbitrary cross sections' - the layout

The central part of the dialog box displays all the arbitrary cross sections currently present in the database, while the right part displays the commands for working with them.

- Left** The button upon activating which changing the position of the arbitrary cross section in the database, by moving towards left, is performed.

- Right** The button upon activating which changing the position of the arbitrary cross section in the database, by moving towards right, is performed.

- Add** The button upon activating which a new cross section is inserted into the database. Upon activating it, the program goes to the drawing and, from the command bar, demands you to select the cross section:

Selecting object:

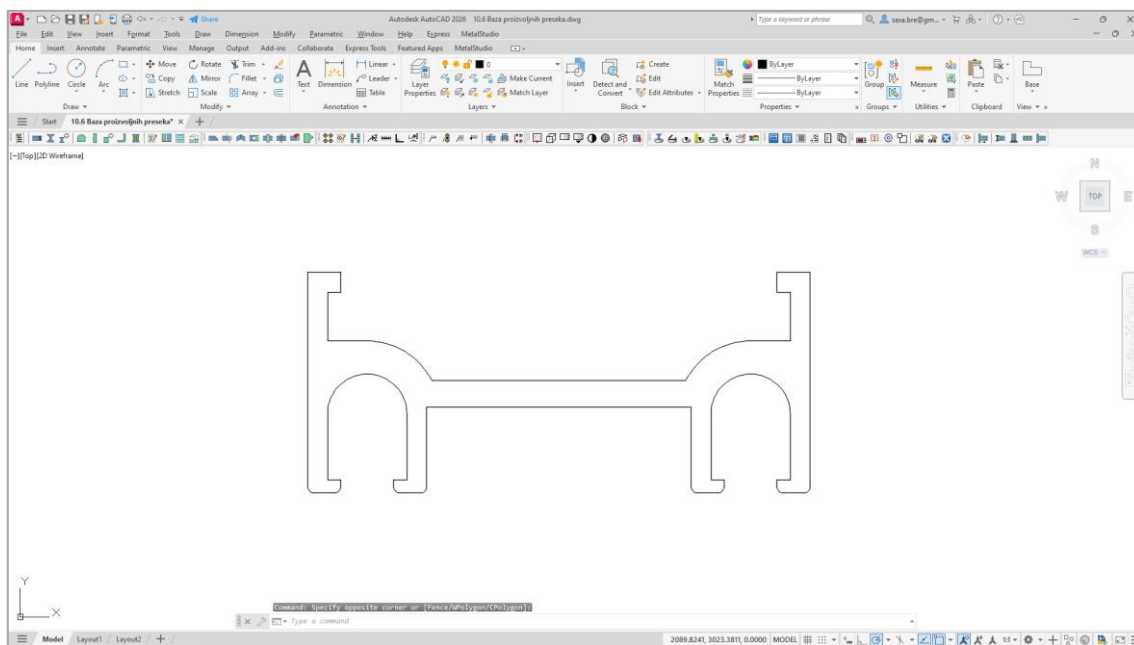

Cross section geometry is assigned using AutoCAD command 'Polyline'

Selected cross section is inserted into the first empty spot of the database.

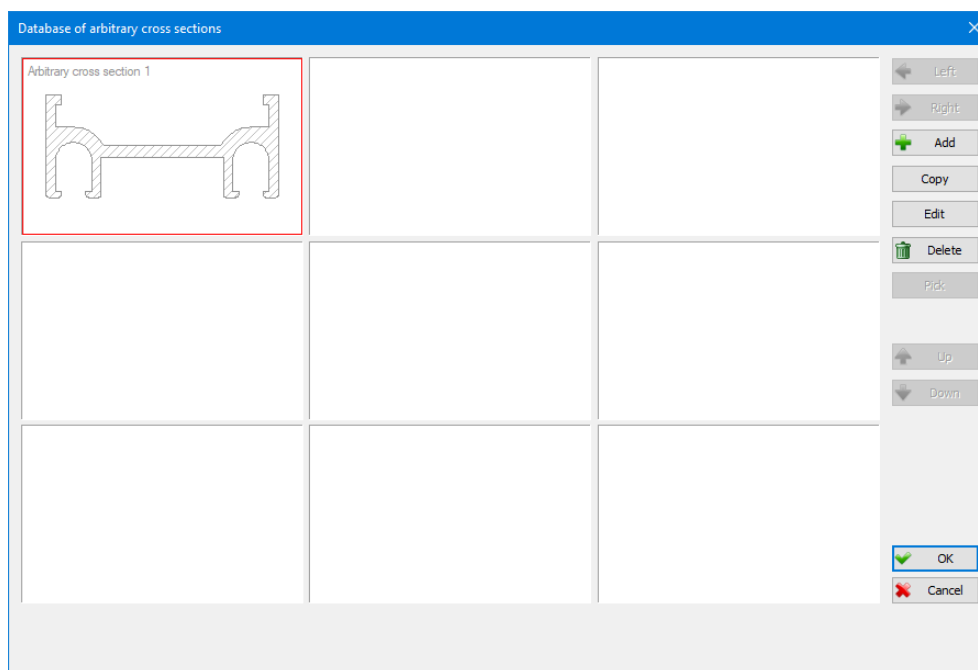

New 'Arbitrary cross section' is inserted into the database by using the 'Add' button.

Copy

The button upon activating which inserting of the cross section, by copying the geometry of currently selected cross section, is performed by the program.

Edit

Either by activating this button, or double-clicking on some of arbitrary cross sections, the dialog box for defining the additional parameters of selected cross section opens up.

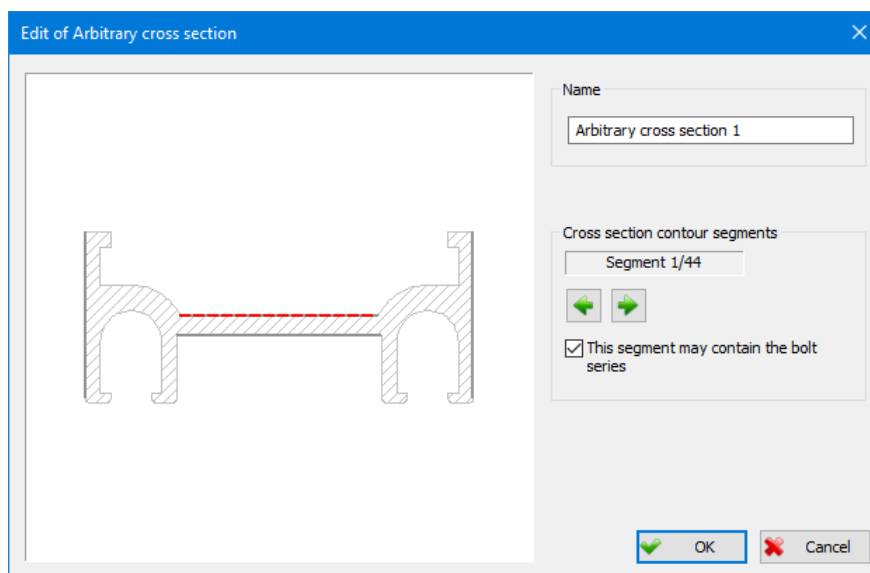

The dialog box for defining the parameters of arbitrary cross section- the layout

The left part of the dialog box displays the geometry of selected cross section.

Name This edit box enables you to assign an arbitrary name to the selected cross section. While drawing the girders with provided cross section, its description in the label will be the assigned name, and in case it is not assigned, there will be the text 'Arbitrary cross section' displayed.

Cross section contour segments

Considering that the cross section geometry may be completely arbitrary, it is necessary to define which contour segments the bolt series can be placed on. Selected contour segment is marked in red, and for the purpose of easier parameter assigning, the program assigns, to every contour segment, a number, which is displayed, for the current segment, along with the overall number of segments.



Buttons for changing the current contour segment. Contour segment may be also be selected with a simple click from the drawing in the dialog box.

This segment may contain the bolt series

By enabling this check box, placing the bolt series on the currently selected contour segment is allowed. Segment this check box is turned on for is displayed in dark gray, so that the user may easily which segments the bolt series is being placed onto, and, if needed, change it. It is necessary to mention that the check box will be inactive in case the arch segment is currently selected.

By activating the '**OK**' button, the assigned changes are accepted, and the program returns to the main dialog box of this command.

Delete

Deleting the selected arbitrary cross section from the database.

Up

In case all the arbitrary cross sections can not be displayed at the same time, activating this button will result in changing the current side upwards.

Down

In case all the arbitrary cross sections can not be displayed at the same time, activating this button will result in changing the current side downwards.

All the arbitrary cross sections in the database will be available for choosing from the 'Cross section type' list, in the dialog boxes for defining the plan view of new girder and the cross section of new girder.

10.7 Setting profiles colors

Using the '**Setting profiles colors**' command, a completely arbitrary color can be assigned to each profile in the currently active profile database. Selecting it from the '**Metal Studio**' drop-down menu or clicking on the icon  opens a dialog with the following appearance:

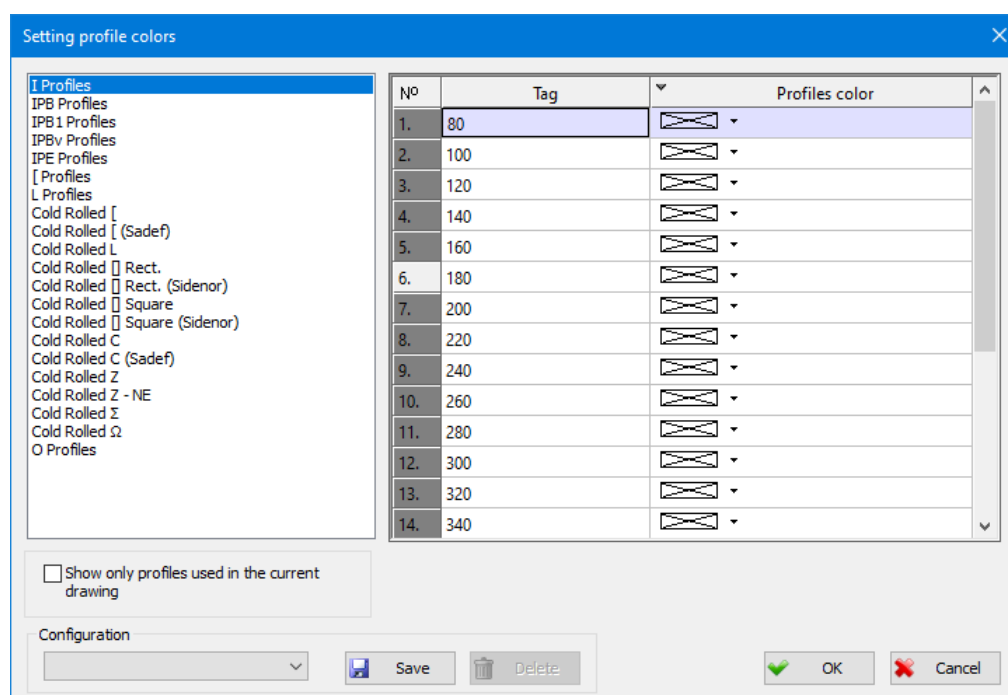

In the left part of the dialog there is a list of all types of profiles that exist in the currently active database. By selecting one of them, a table with all profiles of the selected type will appear in the right part of the dialog. Table columns have the following meaning:

Nº Serial number of the profile in the profile database

Tag The tag of a given profile assigned to it in the profile database

Profiles color The column in which the given profile is assigned a color. Left-clicking the mouse over the field in this column opens a dialog for choosing the desired color:

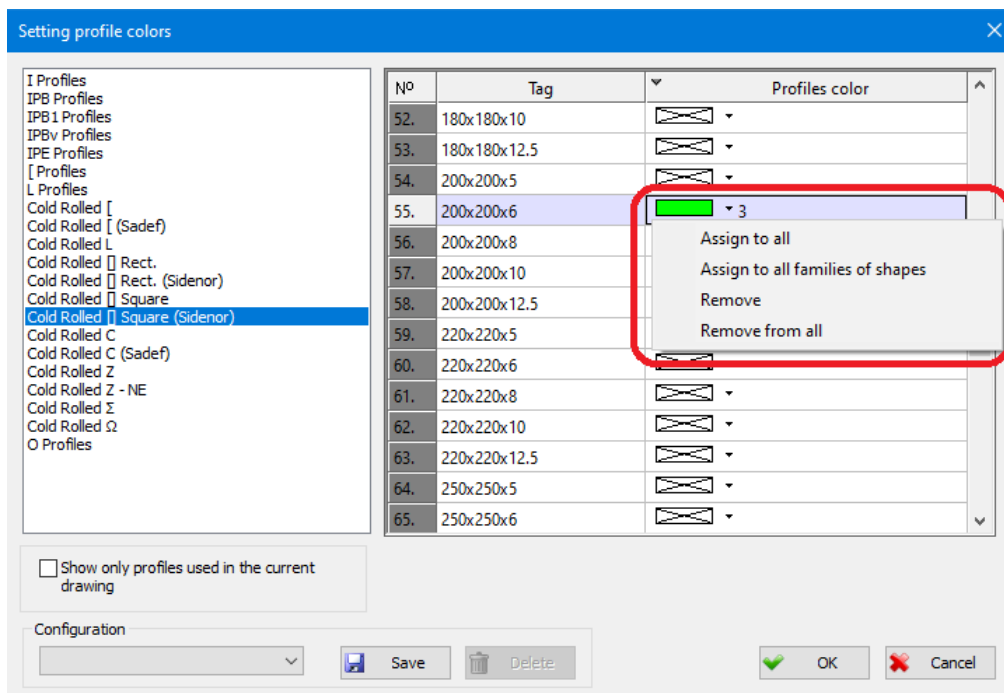

Assign to all - The color assigned to the given profile will be assigned to all profiles of the selected profile type from the list.

Assign to all families of shapes- The color assigned to a given profile will be assigned to all profiles from the profile database.

Remove - Selecting this menu item will remove the color previously assigned to the given profile.

Remove from all - Selecting this menu item will remove the colors previously assigned to all profiles of the selected type from the list.

Show only profiles used in the current drawing - As the name suggests, when this switch is on, only the profiles used in the current drawing are displayed in the table:

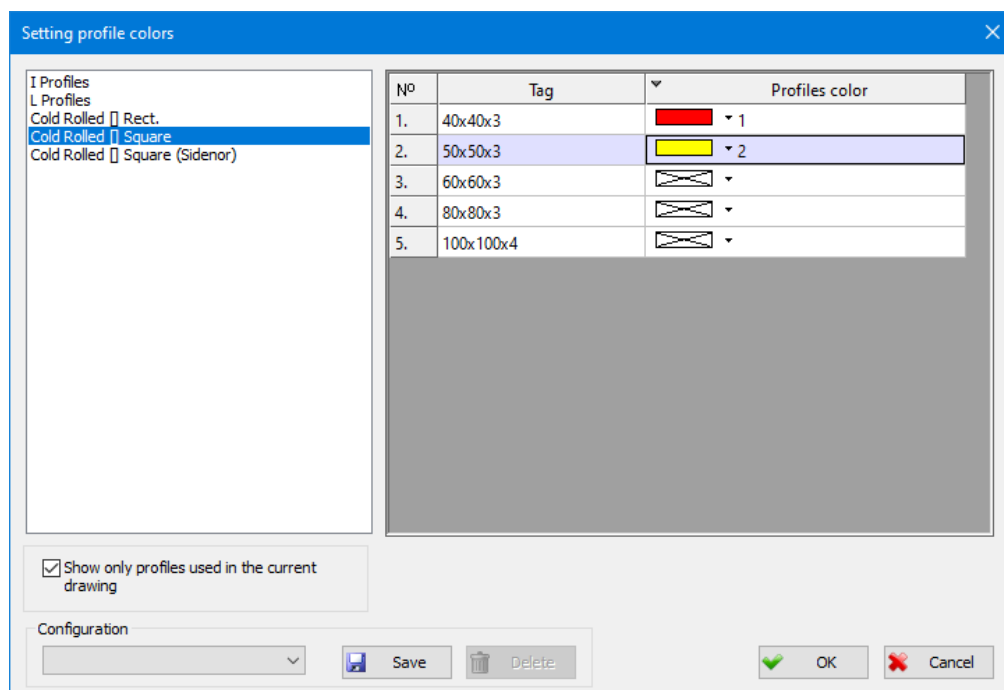

The table shows only the profiles used in the current drawing, and belong to the profile type HOP [] square

Configuration

From the closed list, you can choose one of the previously saved profile color configurations.



Save

A button with which the state of all parameters set in this dialog can be recorded under an arbitrarily given name.



Delete

A button that can be activated to delete the current configuration.

After exiting the dialog of this command, all existing girders in the drawing will be displayed with a new color, if it is assigned to their profile. Also, all new bars that are drawn after it is assigned will be displayed with the given color.

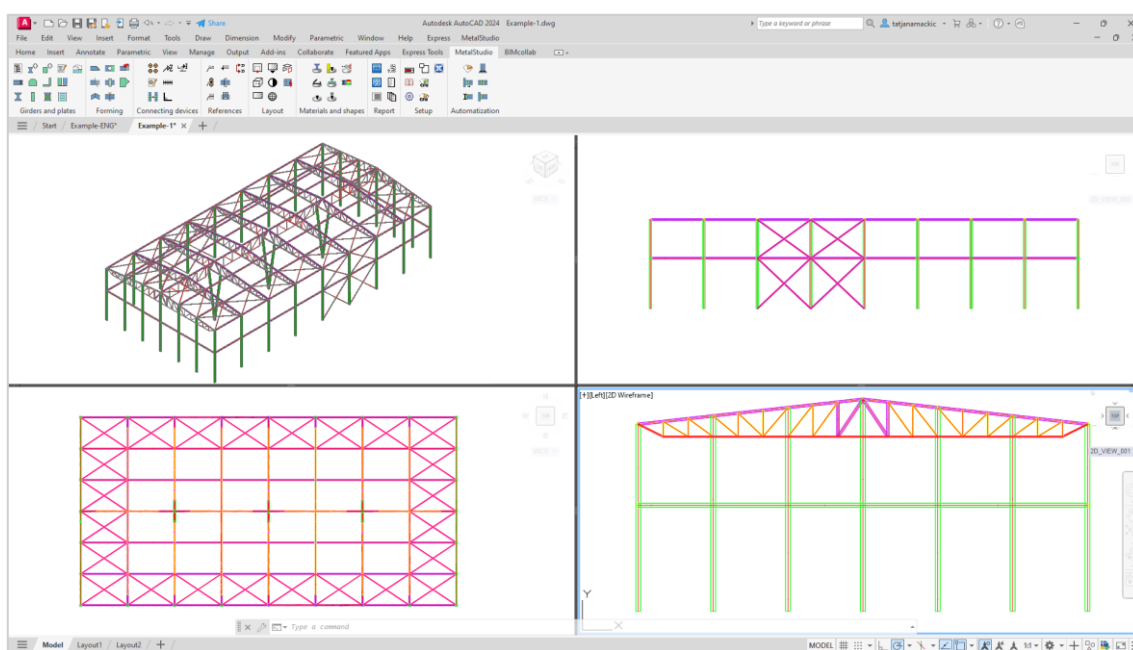

All HOP profiles marked 200x200x6 are shown in the drawing with the default green color

Note: In Metal Studio, girders can be colored in several ways. Therefore, one must take care of the hierarchy, that is, the importance of each of them, in order to get the desired result in the end. Here we will show all the ways to assign colors from the weakest to the most important:

- Entity color set within the 'Parameters' command
- Color set using the 'Entity layout' command
- Color set using the 'Setting profiles colors' command
- Color set using the 'Assembly positions' command

The 'Entity layout' and 'Setting Profiles Color' commands in this hierarchy can be replaced by changing the 'Girder Colors' setting in the 'Functionality' command dialog.

This would mean that if the girder color is specified within all the above commands, the girders will be displayed with the color specified within the 'Assembly Positions' command.

11. WORKSHOP DRAWING

Using this command enables you to generate the workshop drawing for the selected girder or plate position, alongside labeled all required types of plan views for the given entity, where the lengths of all segments, positions of holes and bolt series will be labeled.

Either by selecting the **'Generate workshop drawing individually'** command from the **'Metal Studio'** drop-down menu or by clicking on the icon , the message in which you are requested to select from the drawing the entity which you want to display as labeled will appear on the command bar.

Selecting girder or plate [Exit] < Exit >:

Depending on whether a girder or a plate is selected, two different dialog boxes will open, in which all data required for generating the workshop drawing will be defined.

11.1 Girder workshop drawing

If you have selected a girder position or a girder plan view, the program will open a dialog box of the following layout:

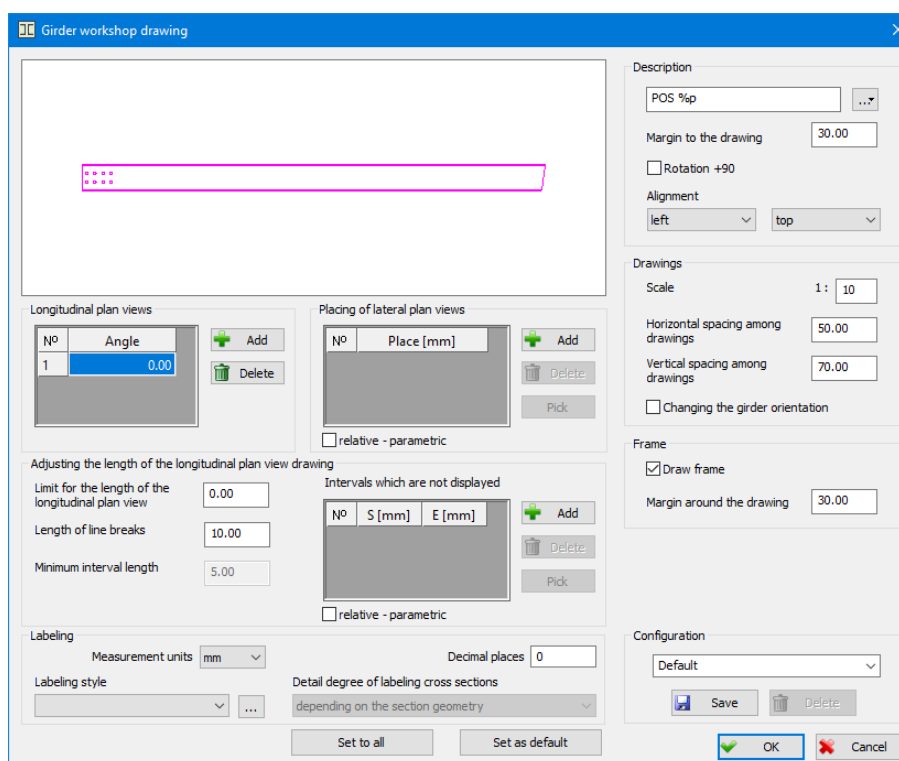

The dialog box for generating the girder workshop drawing - the layout

The top left part of the dialog box displays the layout of the selected girder position with all formings, holes and bolt series.

Since the girder workshop drawing consists of labeled longitudinal and lateral plan views of girder, it is necessary to define appropriate layout parameters for each of these plan views.

Longitudinal plan views

Part of the dialog box which contains parameters for defining the layout of longitudinal plan views of girder.

The list displays all longitudinal plan views which will be labeled in the drawing. The currently selected plan view is displayed in the drawing in the dialog box.

Angle The edit box for entering the angle by which the girder plan view will be defined. Depending on the assigned plan view angle, the girder layout in the dialog box will change.

 **Add** The button upon activating which a new row is inserted into the list. The desired angle is then entered in this new row.

 **Delete** The button upon activating which the selected row is removed from the list.

Placing of lateral plan views

Part of the dialog box which contains the parameters for defining the layout of lateral plan views of girder.

The list displays all lateral plan views which will be labeled in the drawing.

Place The edit box for assigning the place on the girder from which the cross section which will be labeled is taken. The place can be assigned by entering value via the keyboard, either relatively (in millimeters) or parametrically and by taking the place from the drawing, where the given value will be placed in the edit box. The positions of the cross sections are displayed by intermittent lines in the drawing in the dialog box, and the currently selected position is clearly marked.

relative-parametric

When this check box is on, the position of the cross sections will be assigned parametrically (the girder axis length in percentage), in values ranging from - 0.2 to 1.2. On the other hand, when the check box is off, values are assigned relatively in millimeters.

Pick The button upon activating which selecting the position is performed from the drawing in the dialog box from the drawing in the dialog box. This value will be placed in the appropriate edit box. For the purpose of easier position selecting, the current position of the mouse pointer in relation to the beginning of the girder is being displayed in the drawing.

 **Add** The button upon activating which a new row is inserted into the list. The desired position of the lateral plan view is then entered in this new row.

 **Delete** The button upon activating which the selected row is removed from the list.

Adjusting the length of the longitudinal plan view drawing

Since girder length can be quite big and since there is no need to display in the workshop drawing girder parts which have not been modified or bolt holes, it is possible to discard these girder parts. This enables you to adjust the length of the workshop drawing to fit the paper dimensions. Of course, the real value of the plan view length will be displayed on the label lines. This part of the dialog box contains the parameters which are used to define the length of the longitudinal plan views of girders in the workshop drawing.

Adjusting the length of longitudinal plan views can be performed in two ways:

- by assigning the boundary for the length of longitudinal plan view, where the program automatically discards those parts which have not been modified, thus obtaining the plan view of the assigned length;
- and by defining the interval in such a way that the user himself defines intervals on girders which he does not want to display.

Limit for the length of the longitudinal plan view

The edit box for entering the length which the longitudinal plan view will have in the drawing in such a way that the program will automatically discard all girder parts which have not been modified together with bolt holes.

Length of line breaks

The edit box for entering the value of spacing between line breaks, expressed in millimeters.

Minimum interval length

The edit box for entering the value of tolerance for defining the breaks interval. This edit box will become active only if the boundary for the length of the girder drawing is assigned.

Intervals which are not displayed

The list contains all girder parts which you do not want to display in the drawing.

S (Start) The edit box for assigning the beginning position of an interval on the girder which will not be displayed in the drawing. The position can be assigned by entering value via the keyboard, either relatively (in millimeters) or parametrically and by taking from the drawing, where the given value will be placed in the edit box. The intervals which will not be displayed are clearly marked in the drawing in the dialog box.

E (End) The edit box for assigning the end position of an interval on the girder which will not be displayed in the drawing. The position can be assigned by entering value via the keyboard, either relatively (in millimeters) or parametrically and by taking from the drawing, where the given value will be placed in the edit box. The intervals which will not be displayed are clearly marked in the drawing in the dialog box.

relative-parametric

When this check box is on, the interval which is not displayed will be assigned parametrically (the girder axis length in percentage), in values ranging from. - 0.2 to 1.2. On the other hand, when the check box is off, values are assigned relatively in millimeters.

Pick The button upon activating which selecting the interval which you do not want to display is performed from the drawing in the dialog box. This value will be placed in the appropriate edit box. For the purpose of easier position selecting,

the current position of the mouse pointer in relation to the beginning of the girder is being displayed in the drawing.



Add

The button upon activating which a new row is inserted into the list. The desired position of the interval which you do not want to display is then entered in this new row.



Delete

The button upon activating which the selected row is removed from the list.

Description

This part of the dialog box contains the edit box for assigning the parameters which define the contents of the description of the workshop drawing. Activating the button which is located in the continuation of the edit box will open a drop-down menu for selecting the parameters which can be displayed within the description of the workshop drawing. A short description which clearly indicates what the given parameter represents is written in the continuation of the symbol of each parameter.

Margin to the drawing

This edit box enables you to assign the size of the free space from the drawing to the description of the workshop drawing.

Rotation +90 Upon turning this check box on, the position of the description will change, by rotating for 90 degrees. The need for changing the position of the description occurs only in case when the workshop drawing is placed vertically.

Alignment Two combo boxes for selecting the position of the description.

Drawings

Scale This edit box enables you to assign the desired scale of the workshop drawing.

Horizontal spacing among drawings

The edit box for assigning the horizontal spacing among drawings, where the assumed size of the label text is also calculated.

Vertical spacing among drawings

The edit box for assigning the vertical spacing among drawings, where the assumed size of the label text is also calculated.

Changing the girder orientation

When this check box is on, the orientation of drawing the longitudinal plan view will change, which will instantly be displayed in the drawing in the dialog box.

Frame

The parameters which are offered in this part of the dialog box are related to drawing the frame around workshop drawings.

Draw frame Upon turning this check box on, the workshop drawings will be framed.

Margin around the drawing

This edit box enables you to assign the size of the free space around the workshop drawing.

Labeling

Part of the dialog box which contains the parameters for defining the labeling style of longitudinal and lateral plan views of girder.

Measurement units

The combo box for selecting the units of measurement (m, cm, mm, ...) in which data on girder dimensions will be expressed.

Number of decimal places

This edit box enables you to assign the number of decimal places with which data on dimensions of longitudinal and lateral plan views will be displayed in the label.

Detail degree of labeling cross sections

The combo box for selecting one of the three offered styles of labeling lateral plan views. This combo box becomes active only if labeling of cross section has been selected.

depending on the section geometry – the program will automatically define the detail degree of labeling of lateral plan view of girder depending on the section. For rolled sections, it will define labeling of bounding box, whereas for standard sections it will define detailed labeling style.

bounding box style – only the bounding box of the cross section will be labeled, regardless of the section.

detailed style - lateral plan views of girder will be labeled in detail, meaning that all dimensions of cross section (flange thickness, web, etc) will be labeled, regardless of the section.

Labeling style From this combo box, you can select any of the previously defined configurations of labeling styles, for longitudinal and lateral plan views.



The button upon activating which the '**Labeling style**' dialog box opens up.

The dialog box for defining labeling styles of longitudinal and lateral plan views of girder - the layout

The dialog box is divided into two parts, so that the left part contains the parameters for defining the layout of horizontal labels whereas the right part contains the layout of vertical labels.

Horizontal labels

Labeling style The combo box for selecting one of the offered labeling styles.

From left to the apex – labeling each contour apex is performed in a special order, in such a way that each row of labels starts from the left girder apex and ends at the apex which is being labeled.

From right to the apex - labeling each contour apex is performed in a special order, in such a way that each row of labels starts from the right girder apex and ends at the apex which is being labeled.

From the closer edge to the apex - labeling each contour apex is performed in a special order, in such a way that each row of labels starts from the girder edge which is closer to the apex which is being labeled and ends at that apex.

Labeling segments – labeling is performed by segments.

Without labeling the contour – the contour of longitudinal and lateral plan views is not labeled.

Position of labels

The combo box for selecting the position of label.

Down – All labels are located below the drawing.

Up – All labels are located above the drawing.

Down first – The first rows of labels are placed below the drawing and all others above.

Up first - The first rows of labels are placed above the drawing and all others below.

The closer side - Labels are placed up or down depending on which side the segment i.e. the apex which is being labeled is closer to.

Filling blank spaces within rows of labels

When this check box is on, in case that such labeling style is selected when a row of labels contains blank spaces, the program will automatically fill them in.

Spacing to the first row of labels

The edit box for entering the distance from the drawing to the first row of labels.

Spacing among the next rows of labels

The edit box for entering the spacing among rows of labels.

Labeling holes and bolt series

The combo box for selecting one of the offered styles of labeling holes and bolt series.

Down – Labels are placed below the hole or the bolt series.

Up – Labels are placed above the hole or the bolt series.

Outside - Labels are placed outside the girder, and the method is defined by the selected type of labeling from the 'Labeling style' combo box.

Without labeling - holes and bolt series will not be labeled.

Merging adjacent equal labels

If a single row contains several equal labels with which holes from bolt series are labeled, upon turning this check box on, such labels will merge into one label, and the number of recurrences of the same label multiplied by the number which was on the label (for example, 'n*50' where n represents the number of recurrences of the same label) will be written on the label.

Label all bolt series together

When this check box is on, holes from all bolt series will be labeled together.

Vertical labels

The method of defining vertical labels is the same as the method of defining horizontal labels, which is why it will not be described again.

Labeling to the girder axis

When this check box is on, the spacing to the girder axis will be labeled.

Configuration The combo box which contains all previously saved configurations of labeling styles of the workshop drawing, thus enabling the user to select any of them at any time.

Save

The button upon activating which the configurations of labeling styles of the workshop drawing are saved in the database. This is performed so that the state of all parameters defined in this dialog box will be permanently remembered under an arbitrarily assigned name.

Delete

The button upon activating which the configuration of labeling style which has been set as the current one is deleted.

Activating the '**OK**' button will indicate the acceptance of all actions performed in the dialog box, whilst the '**Cancel**' button is intended for quitting.

Upon exiting the dialog box for selecting a labeling style, the program will return to the basic dialog box for defining the workshop drawing.

Unfold pipes drawings

If a girder with circular or tubular cross section is chosen, the dialog box will also contain the parameters for placing the unfold pipes drawings.

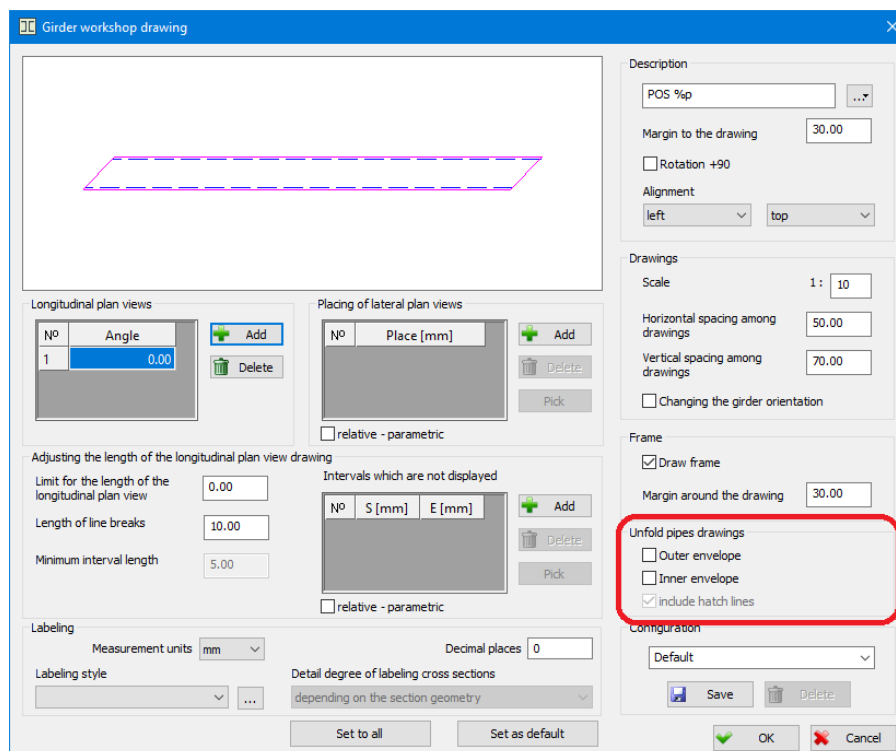

Outer envelope

When this check box is on, outer developed envelope of the chosen girder is placed in the drawing.

Inner envelope

When this check box is on, inner developed envelope of the chosen girder is placed in the drawing. In case the selected girder has the circular cross section, this check box will not be displayed in the dialog box, considering the fact such a girder has only one envelope.

include hatch lines

When this check box is on, developed envelope with the hatch lines are placed in the drawing.

Configuration

From this combo box, you can select any of the previously saved configurations of the workshop drawing.

 **Save**

The button upon activating which, the program will permanently remember and save under an arbitrarily assigned name the state of all parameters defined in this dialog box.

 **Delete**

The button upon activating which, the configuration which has been set as the current one is deleted.

Set to all

The button upon activating which, the state of all parameters in this dialog box will be added to all girder positions which are currently located in the drawing.

Set as default

The button upon activating which, the current configuration is set as the default. In other words, the given configuration will be set as the current one for all girder positions which are created afterwards.

Activating the '**OK**' button will indicate the beginning of the procedure for placing the workshop drawing to which all data assigned in the dialog box will be added, and you will be requested from the command bar to specify the position of the reference point in the drawing:

Reference point:

Upon assigning the reference point, the command bar will obtain a new layout, and you will be further requested to assign the angle of the drawing inclination with respect to the horizontal:

Angle:

11.2 Plate workshop drawing

If you have selected a plate position or a plate plan view, the program will open a dialog box of the following layout:

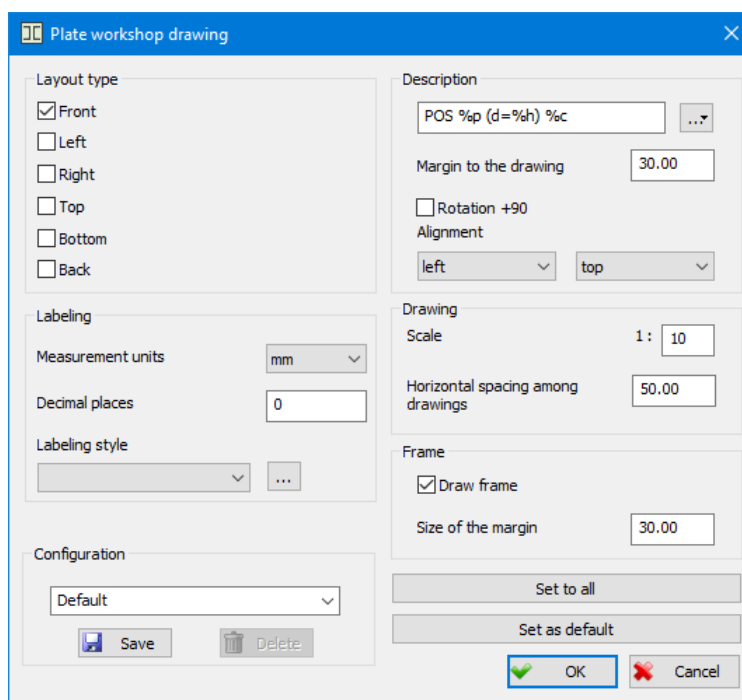

The dialog box for generating the plate workshop drawing - the layout

Layout type Since the plate workshop drawing consists of multiple labeled plan views, the user is allowed to select the plan views he/she wants to label by turning appropriate check boxes on.

Other data which are defined in this dialog box are the same as in the girder workshop drawing, which is why they will not be explained here again.

Activating the '**OK**' button will indicate the beginning of the procedure for placing the workshop drawing to which all data assigned in the dialog box will be added, and you will be requested from the command bar to specify the position of the reference point in the drawing:

Reference point:

Upon assigning the reference point, the command bar will obtain a new layout, and you will be further requested to assign the angle of the workshop drawing inclination with respect to the horizontal:

Angle:

11.3 Workshop drawings of the entire assembly

Since placing workshop drawings for each entity individually can be extremely painstaking and time-consuming, the program allows for generating workshop drawings of all entities of the selected assembly. Either by selecting the **'Workshop drawings of the entire assembly'** command from the **'Metal Studio'** drop-down menu or by clicking on the icon , a dialog box of the following layout will open up:

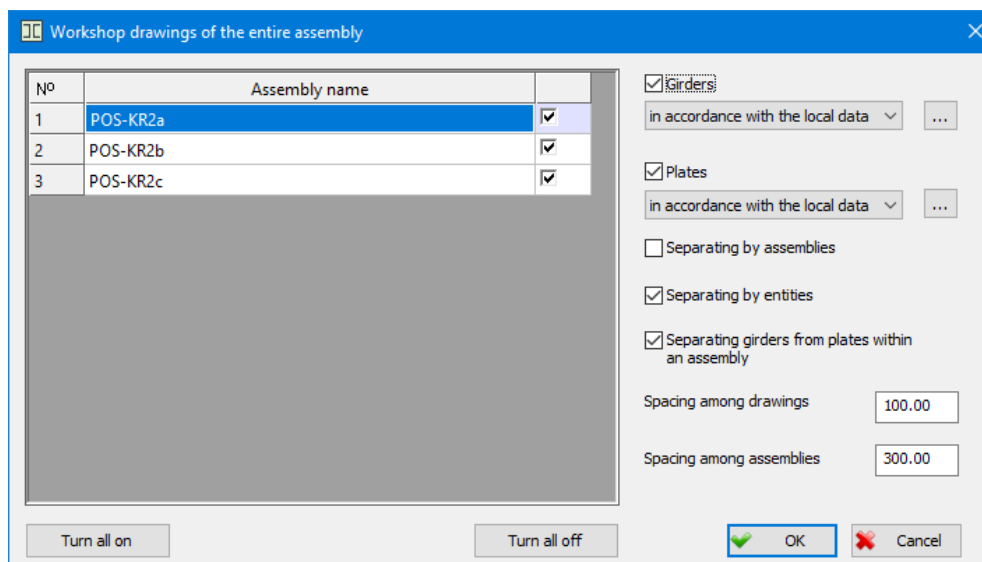

The dialog box for generating workshop drawings of the entire assembly - the layout

The program allows the automatic position disclosure of the girders of specific cross sections and formings, containing the unidentical girders due to the different mirror transformations of their instances, so that by starting the 'Workshop drawings of the entire assembly' command, an appropriate warning will show up:

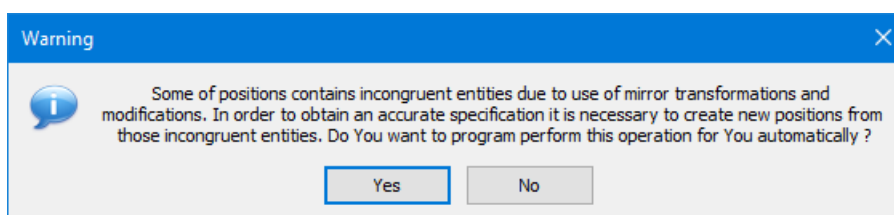

Yes The button whose activation, during the generation of the workshop drawings, results in separation of the positions into two different positions, in case their instances contain different mirror transformations. Separated positions will be permanently saved, and as such, used in the further working of the program.

No The button whose activation results in generation of the workshop drawings without separation of the positions into two different positions, although their instances contain different mirror transformations.

The left part of the dialog box contains a list of all assembly positions which are contained within the drawing. Turning on the check box which is next to the assembly name will indicate that workshop drawings will be generated for the given assembly.

Turn all on The button upon activating which, all check boxes in the list will be turned on.

Turn all off The button upon activating which, all check boxes in the list will be turned off.

Girders

When this check box is on, workshop drawings will be generated for all girders which are located in the selected assemblies.

From the combo box which is below the 'Girders' check box, you can select any of the previously saved configurations of the workshop drawing. In addition to the saved configurations, the combo box also contains the '**in accordance with the local data**' configuration whose setting will indicate that all girders workshop drawings will be generated in accordance with the local data. In other words, they will be generated in accordance with the configuration which has been set for each girder individually, within the '**Generate workshop drawing individually**' command.



The button upon activating which, the dialog box for generating the girder workshop drawing will open up:

The dialog box for generating the girder workshop drawing - the layout

This dialog box is exactly the same as the dialog box which opens in the 'Generate workshop drawing individually' command, which is why working with this dialog box will not be explained here again.

Plates

When this check box is on, workshop drawings will be generated for all plates which are located in the selected assemblies.

From the combo box which is below the 'Plates' check box, you can select any of the previously saved configurations of the workshop drawing. In addition to the saved configurations, the combo box also contains the '**in accordance with the local data**' configuration whose setting will indicate that all plates workshop drawings will be generated in accordance with the local data. In other words, they will be generated in accordance with the configuration which has been set for each plate individually, within the '**Generate workshop drawing individually**' command.



The button upon activating which, the dialog box for generating the plate workshop drawing will open up:

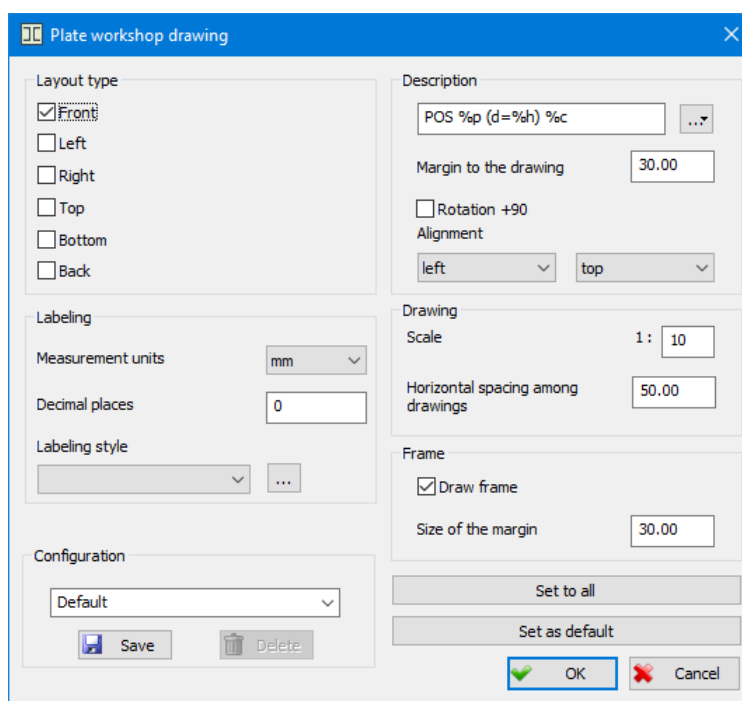

The dialog box for generating plate workshop drawing - the layout

This dialog box is exactly the same as the dialog box which opens in the 'Generate workshop drawing individually' command, which is why working with this dialog box will not be explained here again.

Separating by assemblies

When this check box is on, workshop drawings will be placed by assemblies, so that reference points will be selected for each assembly separately when placing them in the drawings. On the other hand, when the check box is off, all workshop drawings of all assemblies will be placed simultaneously in the drawing. In this case, it will be necessary to select only one reference point for placing, and the spacing among assemblies will be assigned in the 'Spacing among assemblies' edit box.

Separating by entities

When this check box is on, workshop drawings will be placed separately, so that reference point will be selected for each entity, during the placement in the drawing.

Separating girders from plates within an assembly

When this check box is on, first workshop drawings of all girders will be placed within a single assembly, and then workshop drawings of all plates will be placed below them. On the other hand, when the check box is off, workshop drawings will be placed according to the position numbers. This check box becomes active only upon turning the 'Girders' and 'Plates' check boxes on.

Spacing among drawings

The edit box for entering the value of spacing among workshop drawings of the same assembly.

Spacing among assemblies

The edit box for entering the value of spacing among workshop drawings between two assemblies. This edit box becomes active only upon turning the 'Separating by assemblies' check box on.

Activating the **'OK'** button will indicate the beginning of the procedure for placing workshop drawings in the method which is selected in this dialog box, and you will be requested from the command bar to specify the position of the reference point in the drawing:

Reference point:

12. CUSTOMIZING PARAMETERS USED BY THE PROGRAM IN ITS OPERATION

Within the **'Metal Studio ► Setup'** drop-down menu, there is a series of commands designed by the program for customizing parameters which will be used by the program in its operation. In the continuation of this chapter, we shall describe the purpose and functioning of each of them.

12.1 Adjusting colors and fonts for the 'Metal Studio' entities (DRAWING PARAMETERS)

Either selecting the **'Drawing parameters'** command from the **'Metal Studio ► Setup'** drop-down menu or clicking on the icon  will result in opening the dialog box for defining parameters which are used for determining how the drawing will be displayed on the screen.

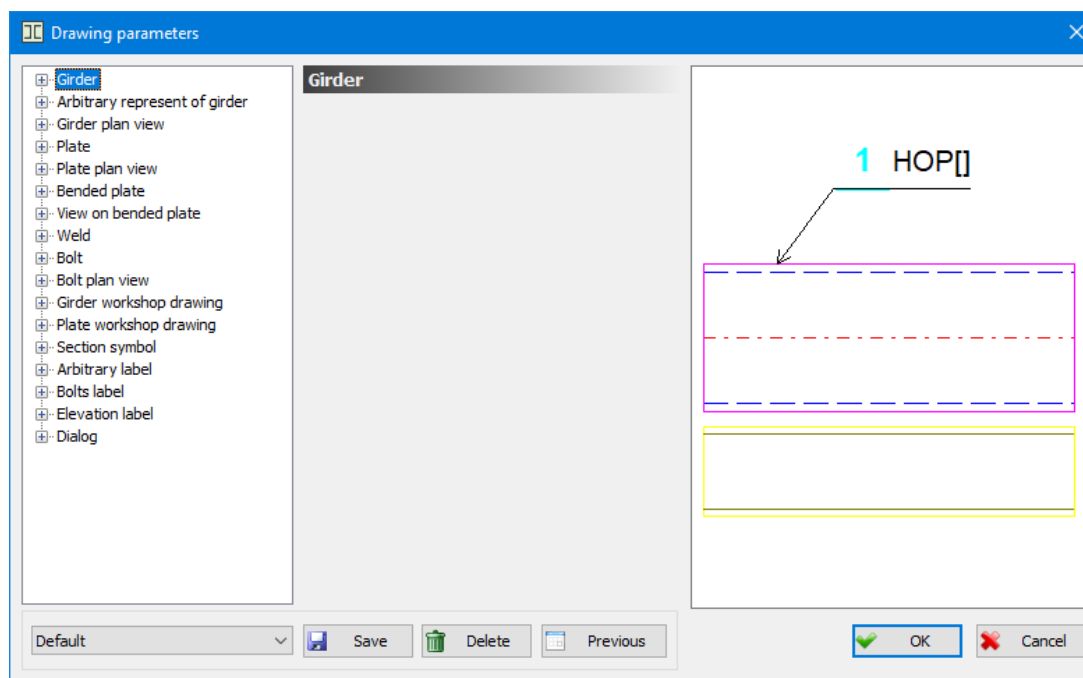

The dialog box within the 'Drawing parameters' command - the layout

Since it is necessary to display large quantities of data in this dialog box, it has been organized into a tree structure. In order to change the contents in the middle of the dialog box, you must select one of the options and its sub-options which are offered in the structure tree. The lower part of the dialog box is common for all data in the structure tree and it works in the same way regardless of which of them is currently being active.

Save

The button upon activating which, the program will permanently remember and save under an arbitrarily assigned name the state of all parameters defined in this dialog box.

**Delete**

The button upon activating which, the configuration which has been set as the current one is deleted.

**Previous**

The button upon activating which you are able to load the state of parameters with which the current drawing was last time saved.

The combo box on the left of the 'Save' button is intended for selecting one of the previously saved configurations.

Upon activating the 'OK' button, the dialog box will close, and the currently set configuration will be used by the program in its further operation until some other configuration is set as the current one by selecting again the 'Drawing parameters' command.

Girder

This part of the structure tree contains parameters which are used for defining the layout type of girder and its labels on the screen.

Edges

The subtitle upon selecting which parameters which are used for defining the layout of visible and invisible girder edges will appear in the central part of the dialog box.

Line type - will open up a drop-down menu for selecting one of the line types designed by the program.

Line color - color of the lines is assigned for girder edges.

Relative line density - density expressed in percentage is assigned for intermittent lines.

Indirect edges

Subheading whose selection will appear in the central part of the dialog with parameters that define the appearance of visible and invisible edges of girders that are not in the plane of the current view.

Line type - opens a drop-down menu for choosing one of the line types provided by the program.

Line color - the color of the lines for the edges of the girder is set.

Relative line density - set the density for dashed lines expressed in percentage.

Axis

The subtitle upon selecting which parameters which are used for defining the layout of the girder axis will appear in the central part of the dialog box.

Line type - will open up a drop-down menu for selecting one of the line types designed by the program.

Line color - color of the girder axis is assigned.

Relative line density - density expressed in percentage is assigned for intermittent lines.

Label line

The subtitle upon selecting which parameters which are used for defining the layout of the girder label line in the drawing will become available for change.

Color - color of the girder label line is assigned.

Symbol type - will open up a drop-down menu for selecting one of the symbol types designed by the program, which will be placed in the girder intersection point and its label line.

Symbol size - size of the selected symbol is assigned on paper in millimeters.

Arrow angle - this edit box is displayed in the dialog box solely in case one of the available arrow type is chosen from the 'Symbol type' list. The angle between label line and arrow edges is assigned here.

Label text

The subtitle upon selecting which parameters which are used for defining the layout of the girder label text in the drawing will become available for change.

Position number - parameters which are used for defining the layout of the girder position number are assigned. From the combo box, you can select the font with which the position number will be written, whereas the font size is assigned (on paper in millimeters) in the edit box in the continuation of the

combo box. Using the  button enables you to add the state of parameters you have defined in this dialog box to the label texts of all 'Metal Studio' entities.

Symbol type - will open up a drop-down menu for selecting one of the symbol types designed by the program, in which the girder position number will be written.

Symbol color - will open up a dialog box for assigning the color of the chosen symbol, where the number of the girder position will be entered.

Relative symbol size - The edit box for entering the size of the selected symbol, in percentage of the assigned value of the position number which is written in the given symbol.

Roman numerals - if the check box is off, girder position numbers will be written in Arabic numerals, whereas if the check box is on, girder position numbers will be written in Roman numerals.

Ordinal numbers - if the check box is on, girder position numbers will be followed by a point.

A.t. - the list for defining the display style for the additional position tags in the label. In case the option '**None**' is chosen from the list, the additional tag is not being displayed. The choice of any of the three remaining options from the list indicates that the additional tag is displayed and, at the same time, its position in the label is defined: in front of the position number, behind the number or the additional position tag is displayed instead of the number.

Assembly tag - list which is used for defining the display style for the assembly tag in the labels of entities that belong to it. In case the option '**None**' is chosen from the list, the tag is not being displayed. The choice of any of the two remaining options from the list indicates that the assembly tag is displayed and, at the same time, its position in the label is defined: in front of the position number or behind of the position number.

Label text - parameters which are used for defining the layout of the text which is written in the girder label. Working with these parameters is the same as working with the parameters which are located in 'Position number' part of the dialog box.

Girder plan view

This part of the structure tree is intended for assigning not only the previously described parameters but also the data on the pattern type and boundary line.

Hatch

The subtitle upon selecting which parameters which are used for defining the pattern of the girder plan view in the drawing will become available for change.

Color - color of the pattern is assigned.

Pattern type - will open up a drop-down menu for selecting one of the pattern types designed by the program.

Pattern density - the edit box for assigning the pattern scale factor.

Boundary line

The subtitle upon selecting which parameters which are used for defining the boundary line of the girder plan view (the line with which the plan view ends) will become available for change. Working with these parameters is the same as working with the parameters which are located in part of the 'Edges' dialog box.

Line continuation - the edit box for assigning the continuation of the boundary line expressed in millimeters.

Dialog

Entity colors and sizes

Subheading whose selection will appear in the central part of the dialog with parameters used to define the appearance and size of entities in dialogs.

Color of the selected entity - sets the color of the selected entity in the dialog.

Selected point color - the color of the selected point in the dialog is set.

Point size - the point size in the dialog is set.

Reference point color - the color of the reference point in the dialog is set.

Label size - the size of the label is set in the dialog.

Color of alignment line - the color of the alignment line in the dialog is set.

Everything that has been previously stated for girder and girder plan view will also apply to all other entities in the drawing, which is why they will not be explained here in detail again.

12.2 Defining the labeling styles of the 'Metal Studio' entities (LABELING STYLES)

Either selecting the '**Labeling styles**' command from the '**Metal Studio ► Settings**' drop-down menu or clicking on the icon  will result in opening the dialog box for defining the labeling styles of the 'Metal Studio' entities.

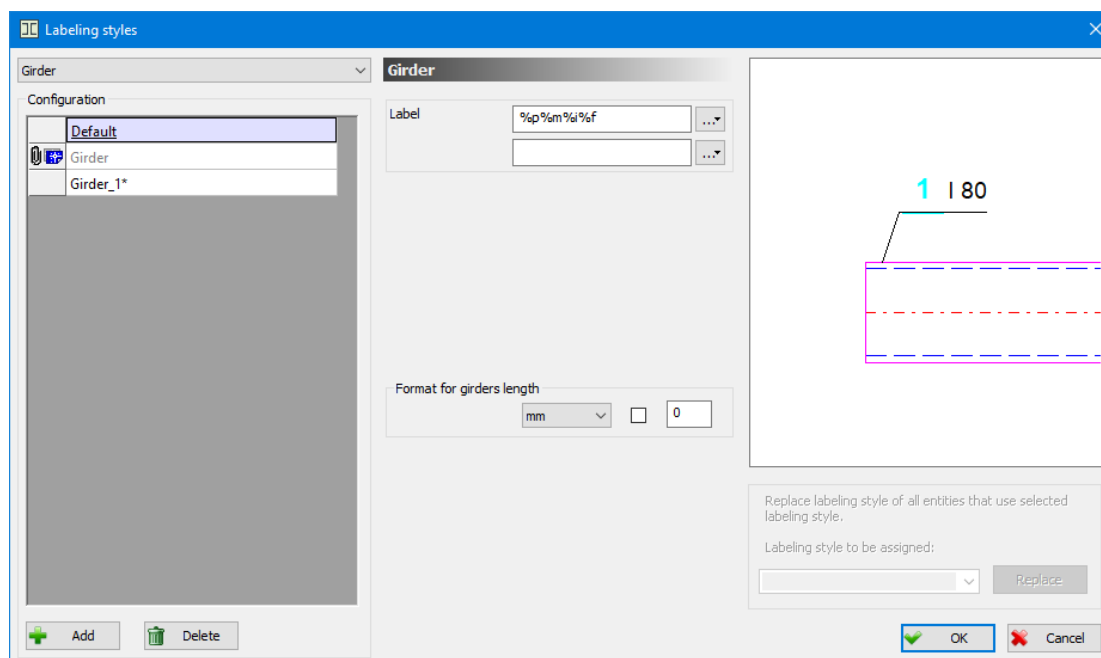

The dialog box defining the labeling styles - the layout

Entity The combo box from which a 'Metal Studio' entity is selected.

Configuration The table displays all previously defined labeling styles.

As you may have noticed, certain symbols have been placed next to the names of some labeling styles in the table. These symbols have the following meaning:



The labeling style is currently used in the drawing.



The labeling style does not exist in the database of configurations - it has been loaded with the current drawing.

` * '

The program places this symbol on the right of the name of the labeling style, when a certain change is made in the database of configurations. The symbol indicates that performed changes have not been saved, and, at the moment of saving, the program will automatically remove it.

The labeling style whose name is underlined in the list represents the labeling style of the given entity. This practically means that the program will offer this labeling style as the default labeling style when placing the given entity in the drawing. The current labeling style can be changed via the 'Set' sub-option which appears on the command bar upon selecting the 'Label' command.



Add

The button upon activating which, the program will insert a new labeling style at the end of the list. This new labeling style has the same parameters as the labeling style which was selected prior to the activation of this button. Since the labeling styles in the list cannot have the same name, the program will add the first free ordinal number to the name of the inserted labeling style.



Delete

The button upon activating which, the currently selected labeling style is removed from the list. This button will become active only when there is more than one labeling style in the database of configurations.

All labeling styles which have been saved in the database of configurations will appear in the lists for selecting a labeling style, in all dialog boxes in which the selection is made possible.

The program automatically saves the changes made to the labeling styles in the configuration database every time the dialog is exited by clicking the 'OK' button.

Deleting duplicates

While working with the program, several of the same labeling styles may accumulate in the database. This most often happens when working on the same drawing on several different computers with different labeling styles. Using the 'Delete Duplicates' command, accumulated labeling styles can be quickly removed from the database. The command is launched from a drop-down menu that is opened by hovering the mouse pointer over any labeling style in the list and pressing the right button.

Replace labeling style of all entities that use the selected labeling style.

Labeling style to be assigned

A closed list from which to select a labeling style that will be assigned to all entities that use the selected labeling style.

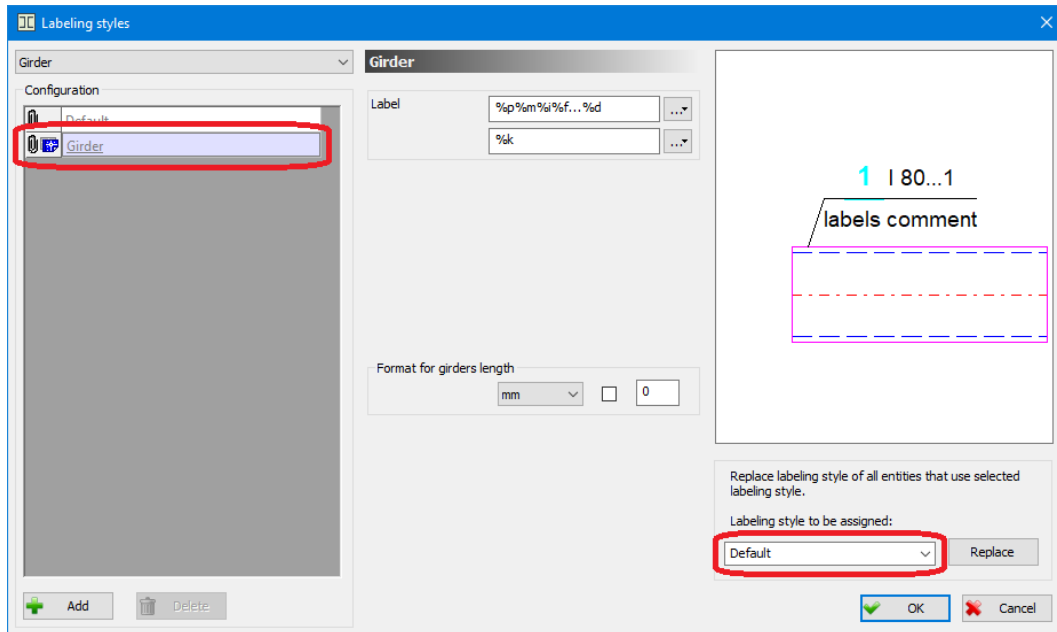

Entities using the 'Girder' labeling style will be assigned the 'Default' labeling style

Replace

This button becomes available only when a labeling style is selected from the 'Labeling style to be assigned' list. By activating it, the labeling style is replaced by all entities that use the labeling style selected in the 'Configuration' table with the labeling style selected from the list. As these are changes that significantly affect the drawing, the program will open a new dialog with a detailed description of the requested replacement of the labeling style and will request its confirmation.

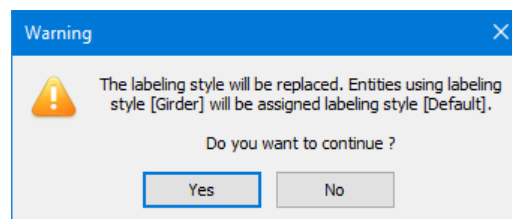

The central part of the dialog box displays the parameters which are used for defining the selected labeling style. We should just point out that different parameters are offered for different 'Metal Studio' entities which are selected from the 'Entity' combo box.

Girder

When you set the 'Girder' entity as the current one by selecting from the 'Entity' combo box, the parameters which are used for defining the girder labeling style will be displayed in the central part of the dialog box.

Label

This part of the dialog box contains the edit boxes in which you can assign the parameters which define the contents of the girder label text. The parameters assigned in the upper edit box define the contents of the label text which is written above the label line, whereas the parameters assigned in the lower edit box define the contents of the label text which is written below the label line. Activating the buttons which are located in the continuation of these edit boxes leads to opening the drop-down menu for selecting parameters which can be displayed in the label text. A short description which clearly indicates what the given parameter represents in the label text is written in the continuation of the symbol of each parameter.

Format for girders length

In this part of the dialog box, you can define the layout of the datum on the girder length in the label text. From the combo box, you can select the units (m, cm, mm, ...) in which the datum on the girder length will be displayed, whereas, by using the check box in its continuation, you can define whether the tag of the selected units will be written after the datum on the girder length. The number of decimal places with which the datum on the girder length will be displayed in the label text is assigned in the edit box.

The labeling styles for other 'Metal Studio' entities are defined in the same way, which is why they will not be explained here again.

12.3 Functionality

Using the '**Functionality**' command enables you to customize the way the program functions in order to meet your needs and requirements. Either by selecting this command from the '**Metal Studio ► Setup**' drop-down menu or by clicking on the icon , the dialog box of the following layout will open up:

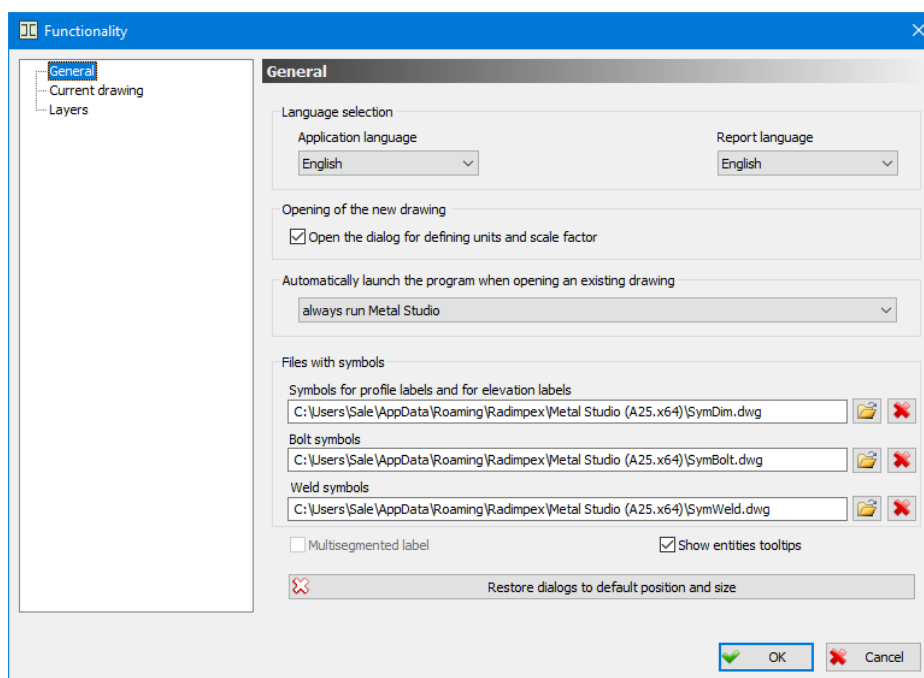

The dialog box within the 'Functionality' command - the layout

Since it is necessary to display large quantities of data in this dialog box, it has been organized into a tree structure. Thus the same space in the dialog box is used for entering different multiple data. The left part of the dialog box displays a tree with names of branches which clearly indicate to which commands the parameters displayed in the right part of the dialog box are related. If you want to change the current branch, you must click over its name, which will also result in changing the contents of the right part of the dialog box.

General

Language selection

This part of the dialog box contains two combo boxes from which you can choose one of the languages intended by the program.

Application language – the combo box for choosing the language to be used by the program in its operation. Thus, the program environment will be in the language you have chosen. The list of languages which will be supported in this box depends on the licence of the program you have bought.

Report language - the combo box for choosing the language in which you want to generate reports. There are no restrictions in this combo box in terms of the licence you have bought, which means that all languages intended by the program will be available all the time.

Open the dialog for defining units and scale factor

When this check box is on, whenever a new drawing is opened, the program will automatically open the same dialog box which would open upon activating the 'Scale' command. On the other hand, when this check box is off, the program will open a new drawing with the default data for scaling (1:10) and units of measurement (mm).

Automatic launch the program when opening an existing drawing

Introduced the ability to adjust the behavior of the program when opening a DWG drawing with Metal Studio entities in AutoCAD where Metal Studio is not currently running, to prevent unwanted starts of Metal Studio.

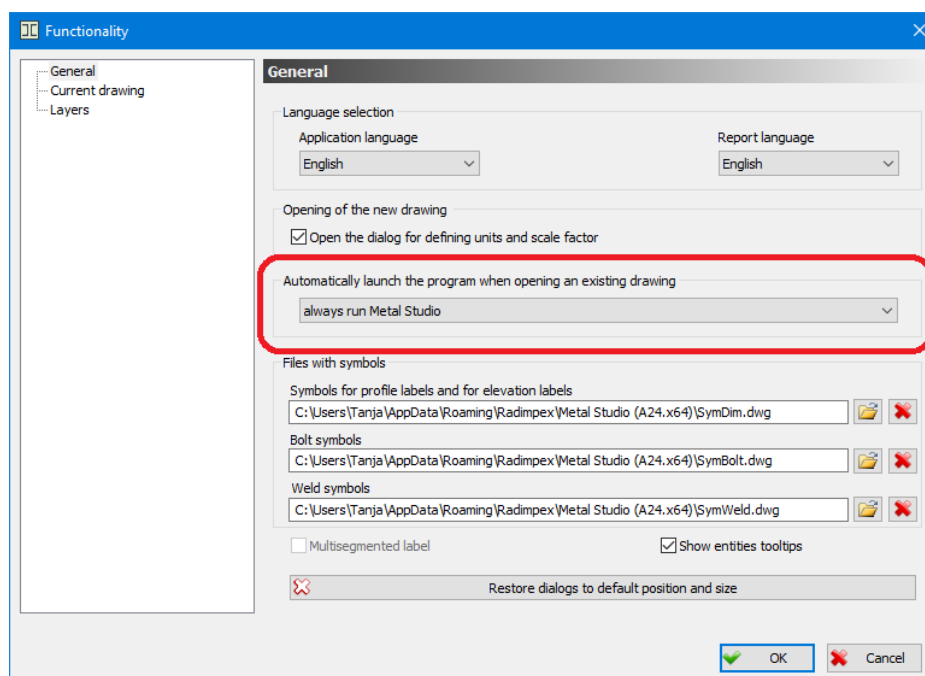

List for defining the behavior of the program when opening a drawing

Choose one of the following options from the closed list:

do not start Metal Studio - the program will not start when loading drawings.

always run Metal Studio - the program starts when loading a drawing. This is the default behavior.

ask about starting Metal Studio - when this option is selected, Metal Studio asks the user whether to start it every time an existing drawing is opened.

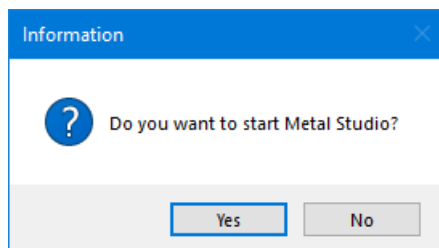

Files with symbols

Files with drawings of symbols the user is free to edit are also delivered with the program.

Profile symbols for label – the edit box in which you can assign the name and the position (on the disk) of the database with section symbols which will be located in the label. These data can also be assigned via the standard 'Windows' dialog box which opens upon activating the '📁' command field. In case the drawing already contains some symbols, and you subsequently chose the new database with the shape symbols in this edit box, choosing the icon  results in resetting the symbols, so that the drawing is being modified by placing the symbols from the new database.

Bolt symbols – the edit box in which you can assign the name and the position (on the disk) of the database with bolt symbols.

Weld symbols – the edit box in which you can assign the name and the position (on the disk) of the database with weld symbols.

Multisegmented label

This check box is intended for defining whether an entity will be labeled either with the standard label whose label line consists of a single segment or with the label whose label line consists of an arbitrary number of segments. Both methods have been explained in detail in the chapter 'Labeling a girder or a plate'.

Show entities tooltips

If the '**Show entities tooltips**' check box is on, and you bring the mouse pointer in the vicinity of any 'Metal Studio' entity in the drawing, the program will display a tooltip with exactly the same contents as the contents of the label text which would be placed for the given entity with the current labeling style.

Restore dialogs to default position and size

Most dialogs in Metal Studio can be resized and positioned on the screen. In order to change the size of the dialog, it is first necessary to place the mouse pointer over one of its edges or over a corner, so that it takes the shape of an arrow that shows the possible stretching directions. After that, press the left mouse button and drag the selected page/corner to the new desired position. Changing the size and position of the dialog is remembered and used every time it is opened. Clicking on this button returns all dialogs in the program to their default position and size.

Current drawing

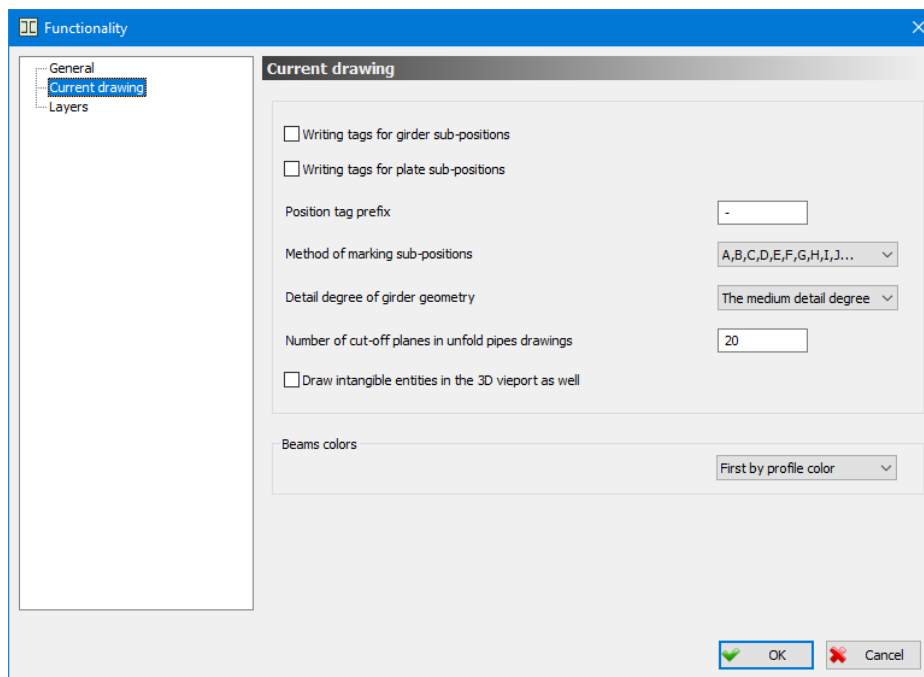

The dialog box for the selected name 'Current drawing' - the layout

Writing tags for girder sub-positions

Since all girders belonging to the same position have the same geometry, and since they can differ from one another only by the position of holes from bolt series, the program allows for allocating automatically sub-positions to the given girders. If the check box is turned on, in such girders, the position number will be followed by a sub-position tag.

Writing tags for plate sub-positions

Since all plates belonging to the same position have the same geometry, and since they can differ from one another only by the position of holes from bolt series, the program allows for allocating automatically sub-positions to the given plates. If the check box is turned on, in such plates, the position number will be followed by a sub-position tag.

Position tag prefix

In this edit box, you can enter the symbol which will precede a sub-position tag in a label.

Method of marking sub-positions

The combo box for selecting one of the methods intended by the program for marking sub-positions.

Detail degree of girder geometry

The combo box for selecting one of the three offered methods of displaying the detail degree of girders: the smallest, medium and the largest detail degree.

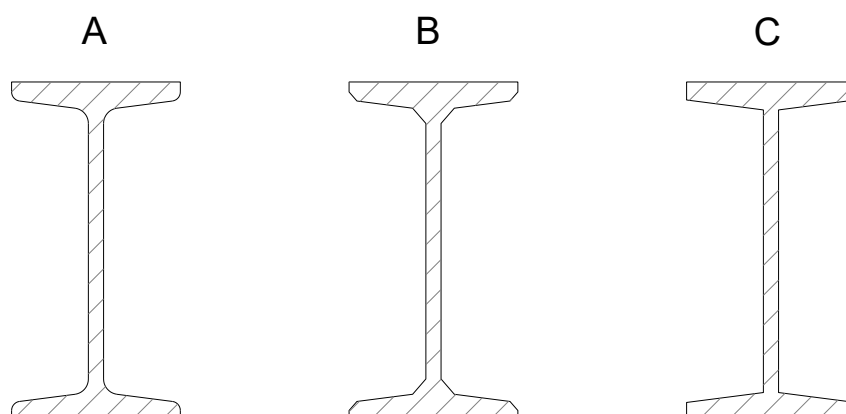

The smallest detail degree: girders in which the detail degree of cross section geometry is turned on (see chapter 9.3. 'Entity layout') will be displayed as shown in figure B, whereas when it is off, they will be displayed as shown in figure .

The medium detail degree: girders in which the detail degree of cross section geometry is turned on will be displayed as shown in figure A, whereas when it is off, they will be displayed as shown in figure C.

The largest detail degree: girders in which the detail degree of cross section geometry is turned on will be displayed as shown in figure A, whereas when it is off, they will be displayed as shown in figure B.

Number of cut-off planes in unfold pipes drawings

The edit box for assigning the number of divisions in the drawing of developed skin. When placing the drawing of developed skin with the pattern is on, the width is divided by the number entered in this edit box, and these spaces are used for drawing the pattern line.

Draw intangible entities in the 3D viewport as well

When this check box is disabled, only material instances of girders and plates are drawn in the 3D view. When the check box is turned on, in addition to the material entities, all intangible entities placed using the Metal Studio program are drawn, such as for example: girder in cross-section, plate in cross-section, workshop drawings of girders and plates, cross-section symbols, elevations, welds, ...

Beams colors **First by entity color** - if this option is selected from the list, the girders are drawn with the color specified in the 'Entity Layout' command.

First by profile color - if this option is selected from the list, the girders are drawn with the color specified in the command 'Setting profile colors'.

Layers

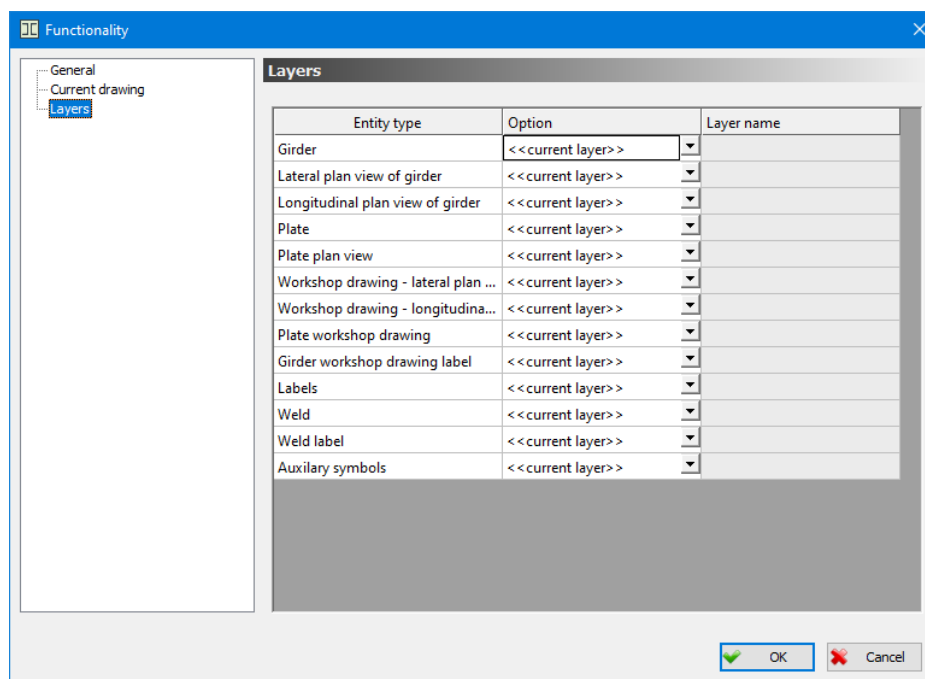

The dialog box for the selected name 'Layers'

The program can place all the 'Metal Studio' entities that will be shown in the drawing into the current 'AutoCAD' layer or into the standard layers with the names for each of the entities, defined by the program. The user is allowed to independently define the layer he/she wants to place some entities into.

Entity type The column with all types of the 'Metal Studio' entities that is possible to define the layers for (the layers they will be placed in, during the drawing).

Option Combo box for the selection of the layer the entities will be placed in.
Current layer - In case this layer is selected, the entity will be placed in the current 'AutoCAD' layer in the drawing.
Standard layer - In case this layer is selected, the entity will be placed in the appropriate layer with the name, defined by the program for every entity, that will be placed in the edit box 'Layer name'.
New layer - In case this layer is selected, the entity will be placed in the new layer, whose name is defined by the user.

Layer name The edit box the user enters the name of the new layer to. In case the standard layer is selected, its name, defined by the program, will be placed in this edit box.

12.4 Adjusting the scale of the drawing

Either by selecting the **'Scale'** command, from the **'Metal Studio ► Setup'** drop-down menu, or by clicking on the icon , a dialog box for defining the scale of the drawing will open up.

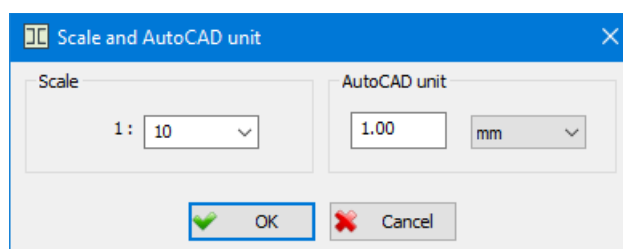

Scale Considering the fact that the text size in the labels of the 'Metal Studio' entities is assigned in millimeters on the paper, it is necessary to also enter the scale the drawing will be transferred to the paper with in the edit box. This scale is entered in the edit box by assigning from the keyboard or by selecting some of the scales defined by program, from the combo box. Assigning the desired scale the drawing will be transferred to the paper with, the program will modify the size of all the labels of the 'Metal Studio' entities, so that their size in drawing units is equal to the given size in millimeters on the paper.

AutoCAD unit This part of the dialog box contains the combo box, which permits the selection of the length units (m, cm, mm, ...) and the edit box for the entering of values that define how many chosen units will represent one 'AutoCAD' unit (ACU) in the drawing. This way, the non-dimensional drawing 'AutoCAD' units and the real lengths of 'Metal Studio' entities are linked.

All the 'AutoCAD' entities (also the 'Metal Studio' entities) remember and display their geometry via the 'AutoCAD' units (ACU). That is a non-dimensional value, and it can represent any length. On the other hand, the 'Metal Studio' entities (girders and plates) are specific objects that must have real dimensions.

The scale you assign in the beginning of the working can be modified at any time by selecting the 'Scale' command, which will effect only the drawing of the texts. However, the data modification in relation to the physical length of the 'AutoCAD' units are to be avoided while working. In case the drawing contains some of the 'Metal Studio' entities, their dimensions in the 'AutoCAD' units will not be modified – solely the manner of transforming the ACU unit to the physical unit will be modified.

Example: If 1ACU=1cm and if a girder of 200 cm length is placed in the drawing (then its length is 200 ACU). Upon modifying, in the scale command, that 1ACU=1mm, that same girder will still have the 200 ACU, where its physical length will be 200 mm.

This shows that the command can be destructive in case it is being applied when the drawing already contains some of the 'Metal Studio' entities, and that, therefore, it is necessary to appropriately define the physical length of one 'AutoCAD' unit prior to working.

We will remark that the dialog box for defining the scale opens up upon every opening of a new drawing.

13. REPORT

The purpose of this command is automatic generation of all the report types: specifications of the plates and girders, recapitulation of the shapes, recapitulation of the plates, overall recapitulation, recapitulation of the bolts per assemblies, recapitulation of the bolts and recapitulation of the washers. The contents of the report corresponds to the current appearance of the drawing. Simultaneously with the generation procedure, the program switches to the special regime of running, that allows the preview, adjustment and printing of the report. The report can be:

- printed
- exported to the AutoCAD drawing.
- converted to RTF (Rich Text Format – the format compatible with many text-processors)

Either by selecting the **'Report'** command from the **'Metal Studio'** drop-down menu or by clicking on the icon , the program reads the current appearance of the drawing and automatically generates the report for all the entities belonging to the current assembly group (see Chapter '13.8'). Instead of the graphical environment of the 'AutoCAD', the window for the working with the generated report will open up.

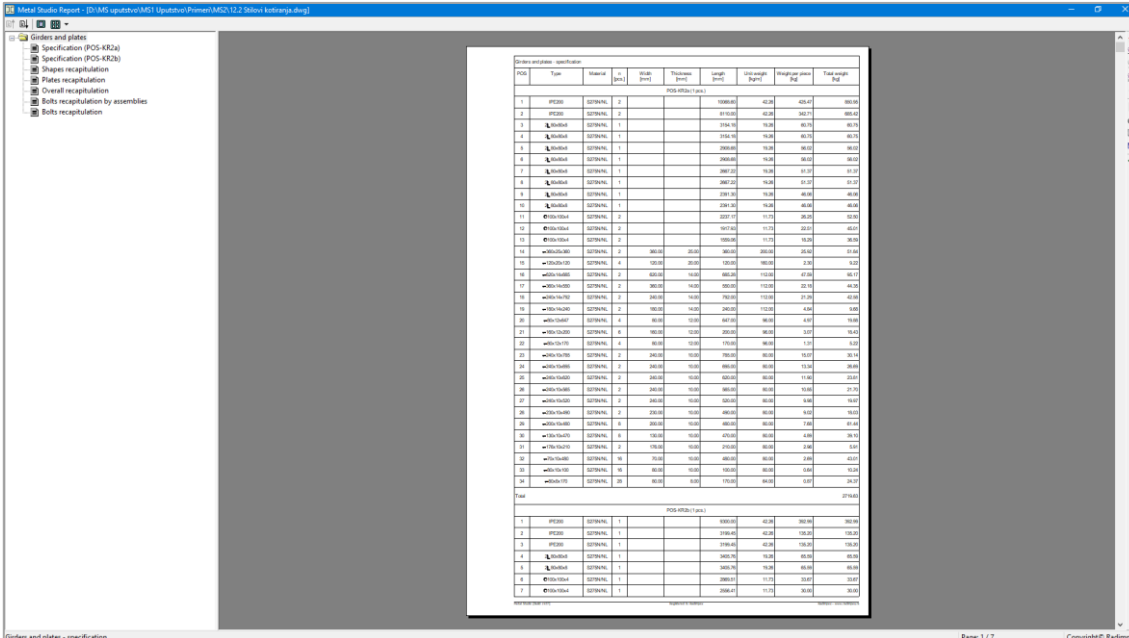

The screenshot shows the 'Metal Studio Report' window. On the left is a tree structure for 'Girders and plates - specification'. The main area displays a table with columns: 'Order', 'Type', 'Material', 'L1', 'L2', 'L3', 'Thickness', 'Length', 'Weight', 'Weight per m', and 'Total weight'. The table is divided into sections for 'Girders (I-beams)', 'Plates', and 'Bolts'. The 'Girders (I-beams)' section lists various I-beam profiles with their dimensions and weights. The 'Plates' section lists different plate sizes and weights. The 'Bolts' section lists different bolt sizes and weights. The table ends with a 'Total' row for each section and a grand total at the bottom.

Order	Type	Material	L1	L2	L3	Thickness	Length	Weight	Weight per m	Total weight
Girders (I-beams)										
1	IPE200	ST37-2	2			10	10000	45.28	45.28	9056
2	IPE200	ST37-2	2			10	8100	45.28	45.28	7665.6
3	IPE200	ST37-2	1			10	216.76	16.28	16.28	16.28
4	IPE200	ST37-2	1			10	216.76	16.28	16.28	16.28
5	IPE200	ST37-2	1			10	216.76	16.28	16.28	16.28
6	IPE200	ST37-2	1			10	216.76	16.28	16.28	16.28
7	IPE200	ST37-2	1			10	216.76	16.28	16.28	16.28
8	IPE200	ST37-2	1			10	216.76	16.28	16.28	16.28
9	IPE200	ST37-2	1			10	216.76	16.28	16.28	16.28
10	IPE200	ST37-2	1			10	216.76	16.28	16.28	16.28
11	IPE200	ST37-2	2			10	207.11	15.55	15.55	31.10
12	IPE200	ST37-2	2			10	191.82	14.39	14.39	28.78
13	IPE200	ST37-2	2			10	185.36	13.75	13.75	27.50
14	IPE200	ST37-2	2			10	178.90	13.11	13.11	26.22
15	IPE200	ST37-2	2			10	172.44	12.47	12.47	24.94
16	IPE200	ST37-2	2			10	165.98	11.83	11.83	23.66
17	IPE200	ST37-2	2			10	159.52	11.19	11.19	22.38
18	IPE200	ST37-2	2			10	153.06	10.55	10.55	21.10
19	IPE200	ST37-2	2			10	146.60	9.91	9.91	19.82
20	IPE200	ST37-2	2			10	140.14	9.27	9.27	18.54
21	IPE200	ST37-2	2			10	133.68	8.63	8.63	17.26
22	IPE200	ST37-2	2			10	127.22	7.99	7.99	15.98
23	IPE200	ST37-2	2			10	120.76	7.35	7.35	14.70
24	IPE200	ST37-2	2			10	114.30	6.71	6.71	13.42
25	IPE200	ST37-2	2			10	107.84	6.07	6.07	12.14
26	IPE200	ST37-2	2			10	101.38	5.43	5.43	10.86
27	IPE200	ST37-2	2			10	94.92	4.79	4.79	9.58
28	IPE200	ST37-2	2			10	88.46	4.15	4.15	8.30
29	IPE200	ST37-2	2			10	82.00	3.51	3.51	7.02
30	IPE200	ST37-2	2			10	75.54	2.87	2.87	5.74
31	IPE200	ST37-2	2			10	69.08	2.23	2.23	4.46
32	IPE200	ST37-2	2			10	62.62	1.59	1.59	3.18
33	IPE200	ST37-2	2			10	56.16	0.95	0.95	1.90
34	IPE200	ST37-2	2			10	49.70	0.31	0.31	0.62
35	IPE200	ST37-2	2			10	43.24	-0.33	-0.33	-0.66
36	IPE200	ST37-2	2			10	36.78	-0.97	-0.97	-1.94
37	IPE200	ST37-2	2			10	30.32	-1.61	-1.61	-3.22
38	IPE200	ST37-2	2			10	23.86	-2.25	-2.25	-4.50
39	IPE200	ST37-2	2			10	17.40	-2.89	-2.89	-5.78
40	IPE200	ST37-2	2			10	10.94	-3.53	-3.53	-7.06
41	IPE200	ST37-2	2			10	4.48	-4.17	-4.17	-8.34
42	IPE200	ST37-2	2			10	-1.98	-4.81	-4.81	-9.62
43	IPE200	ST37-2	2			10	-8.52	-5.45	-5.45	-10.90
44	IPE200	ST37-2	2			10	-15.06	-6.09	-6.09	-12.18
45	IPE200	ST37-2	2			10	-21.60	-6.73	-6.73	-13.46
46	IPE200	ST37-2	2			10	-28.14	-7.37	-7.37	-14.74
47	IPE200	ST37-2	2			10	-34.68	-8.01	-8.01	-16.02
48	IPE200	ST37-2	2			10	-41.22	-8.65	-8.65	-17.30
49	IPE200	ST37-2	2			10	-47.76	-9.29	-9.29	-18.58
50	IPE200	ST37-2	2			10	-54.30	-9.93	-9.93	-19.86
51	IPE200	ST37-2	2			10	-60.84	-10.57	-10.57	-21.14
52	IPE200	ST37-2	2			10	-67.38	-11.21	-11.21	-22.42
53	IPE200	ST37-2	2			10	-73.92	-11.85	-11.85	-23.70
54	IPE200	ST37-2	2			10	-80.46	-12.49	-12.49	-24.98
55	IPE200	ST37-2	2			10	-87.00	-13.13	-13.13	-26.26
56	IPE200	ST37-2	2			10	-93.54	-13.77	-13.77	-27.54
57	IPE200	ST37-2	2			10	-100.08	-14.41	-14.41	-28.82
58	IPE200	ST37-2	2			10	-106.62	-15.05	-15.05	-30.10
59	IPE200	ST37-2	2			10	-113.16	-15.69	-15.69	-31.38
60	IPE200	ST37-2	2			10	-119.70	-16.33	-16.33	-32.66
61	IPE200	ST37-2	2			10	-126.24	-16.97	-16.97	-33.94
62	IPE200	ST37-2	2			10	-132.78	-17.61	-17.61	-35.22
63	IPE200	ST37-2	2			10	-139.32	-18.25	-18.25	-36.50
64	IPE200	ST37-2	2			10	-145.86	-18.89	-18.89	-37.78
65	IPE200	ST37-2	2			10	-152.40	-19.53	-19.53	-39.06
66	IPE200	ST37-2	2			10	-158.94	-20.17	-20.17	-40.34
67	IPE200	ST37-2	2			10	-165.48	-20.81	-20.81	-41.62
68	IPE200	ST37-2	2			10	-172.02	-21.45	-21.45	-42.90
69	IPE200	ST37-2	2			10	-178.56	-22.09	-22.09	-44.18
70	IPE200	ST37-2	2			10	-185.10	-22.73	-22.73	-45.46
71	IPE200	ST37-2	2			10	-191.64	-23.37	-23.37	-46.74
72	IPE200	ST37-2	2			10	-198.18	-24.01	-24.01	-48.02
73	IPE200	ST37-2	2			10	-204.72	-24.65	-24.65	-49.30
74	IPE200	ST37-2	2			10	-211.26	-25.29	-25.29	-50.58
75	IPE200	ST37-2	2			10	-217.80	-25.93	-25.93	-51.86
76	IPE200	ST37-2	2			10	-224.34	-26.57	-26.57	-53.14
77	IPE200	ST37-2	2			10	-230.88	-27.21	-27.21	-54.42
78	IPE200	ST37-2	2			10	-237.42	-27.85	-27.85	-55.70
79	IPE200	ST37-2	2			10	-243.96	-28.49	-28.49	-56.98
80	IPE200	ST37-2	2			10	-250.50	-29.13	-29.13	-58.26
81	IPE200	ST37-2	2			10	-257.04	-29.77	-29.77	-59.54
82	IPE200	ST37-2	2			10	-263.58	-30.41	-30.41	-60.82
83	IPE200	ST37-2	2			10	-270.12	-31.05	-31.05	-62.10
84	IPE200	ST37-2	2			10	-276.66	-31.69	-31.69	-63.38
85	IPE200	ST37-2	2			10	-283.20	-32.33	-32.33	-64.66
86	IPE200	ST37-2	2			10	-289.74	-32.97	-32.97	-65.94
87	IPE200	ST37-2	2			10	-296.28	-33.61	-33.61	-67.22
88	IPE200	ST37-2	2			10	-302.82	-34.25	-34.25	-68.50
89	IPE200	ST37-2	2			10	-309.36	-34.89	-34.89	-69.78
90	IPE200	ST37-2	2			10	-315.90	-35.53	-35.53	-71.06
91	IPE200	ST37-2	2			10	-322.44	-36.17	-36.17	-72.34
92	IPE200	ST37-2	2			10	-328.98	-36.81	-36.81	-73.62
93	IPE200	ST37-2	2			10	-335.52	-37.45	-37.45	-74.90
94	IPE200	ST37-2	2			10	-342.06	-38.09	-38.09	-76.18
95	IPE200	ST37-2	2			10	-348.60	-38.73	-38.73	-77.46
96	IPE200	ST37-2	2			10	-355.14	-39.37	-39.37	-78.74
97	IPE200	ST37-2	2			10	-361.68	-40.01	-40.01	-80.02
98	IPE200	ST37-2	2			10	-368.22	-40.65	-40.65	-81.30
99	IPE200	ST37-2	2			10	-374.76	-41.29	-41.29	-82.58
100	IPE200	ST37-2	2			10	-381.30	-41.93	-41.93	-83.86
101	IPE200	ST37-2	2			10	-387.84	-42.57	-42.57	-85.14
102	IPE200	ST37-2	2			10	-394.38	-43.21	-43.21	-86.42
103	IPE200	ST37-2	2			10	-400.92	-43.85	-43.85	-87.70
104	IPE200	ST37-2	2			10	-407.46	-44.49	-44.49	-88.98
105	IPE200	ST37-2	2			10	-414.00	-45.13	-45.13	-90.26
106	IPE200	ST37-2	2			10	-420.54	-45.77	-45.77	-91.54
107	IPE200	ST37-2	2			10	-427.08	-46.41	-46.41	-92.82
108	IPE200	ST37-2	2			10	-433.62	-47.05	-47.05	-94.10
109	IPE200	ST37-2	2			10	-440.16	-47.69	-47.69	-95.38
110	IPE200	ST37-2	2			10	-446.70	-48.33	-48.33	-96.66

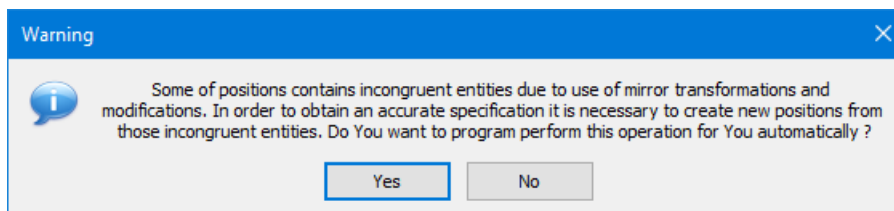

Yes The button whose activation, during the generation of the report, results in separation of the positions into two different positions, in case their instances contain different mirror transformations. Separated positions will be permanently saved, and as such, used in the further working of the program.

No The button whose activation results in generation of the report without separation of the positions into two different positions, although their instances contain different mirror transformations.

13.1 Preview and scope of the report

As aforesaid, the program automatically creates the reports upon activating the command. In case you want some report not to be shown, it is necessary to click (right mouse button) on the option in the tree, concerning that report, whereas the drop-down menu with the '**Show**' and '**Hide**' commands opens up.

Hide By choosing this command, the selected report turns invisible, and its name in the tree is written in gray color.

Show This command is available solely in case the previously hidden report is chosen, and its activation results in showing the given report again.

The user is allowed to perform multiple selection as well. Multiple selection of the reports in the tree is performed under the standard 'Windows' norms:

- If you hold down the 'Ctrl' key, all the reports you click will be selected, while clicking an already selected report will result in its deselection.
- If you hold down the 'Shift', besides the reports you click, all the reports in the tree, between them, will also be selected.

In the right part of the window for working with the report, the layout of the currently active page of the report is being shown, in the way it will appear on the paper, after the printing. In the bottom of the screen, on the status line, information about the currently displayed report chapter, ordinal number of the current page and the total number of the report pages will be placed.

ID	Title	Material	Q. (mm)	Volume (mm ³)	Surface (mm ²)	Weight (g)	Indication	Volume (mm ³)
1	W100-1000	ST37090	1	1000000	1000000	1000000	1000000	1000000
2	W100-1000	ST37090	1	1000000	1000000	1000000	1000000	1000000
3	W100-1000	ST37090	1	1000000	1000000	1000000	1000000	1000000
4	W100-1000	ST37090	1	1000000	1000000	1000000	1000000	1000000
5	W100-1000	ST37090	1	1000000	1000000	1000000	1000000	1000000
6	W100-1000	ST37090	1	1000000	1000000	1000000	1000000	1000000
7	W100-1000	ST37090	1	1000000	1000000	1000000	1000000	1000000
8	W100-1000	ST37090	1	1000000	1000000	1000000	1000000	1000000
9	W100-1000	ST37090	1	1000000	1000000	1000000	1000000	1000000
10	W100-1000	ST37090	1	1000000	1000000	1000000	1000000	1000000
11	W100-1000	ST37090	1	1000000	1000000	1000000	1000000	1000000
12	W100-1000	ST37090	1	1000000	1000000	1000000	1000000	1000000
13	W100-1000	ST37090	1	1000000	1000000	1000000	1000000	1000000
14	W100-1000	ST37090	1	1000000	1000000	1000000	1000000	1000000
15	W100-1000	ST37090	1	1000000	1000000	1000000	1000000	1000000
16	W100-1000	ST37090	1	1000000	1000000	1000000	1000000	1000000
17	W100-1000	ST37090	1	1000000	1000000	1000000	1000000	1000000
18	W100-1000	ST37090	1	1000000	1000000	1000000	1000000	1000000
19	W100-1000	ST37090	1	1000000	1000000	1000000	1000000	1000000
20	W100-1000	ST37090	1	1000000	1000000	1000000	1000000	1000000
21	W100-1000	ST37090	1	1000000	1000000	1000000	1000000	1000000
22	W100-1000	ST37090	1	1000000	1000000	1000000	1000000	1000000
23	W100-1000	ST37090	1	1000000	1000000	1000000	1000000	1000000
24	W100-1000	ST37090	1	1000000	1000000	1000000	1000000	1000000
25	W100-1000	ST37090	1	1000000	1000000	1000000	1000000	1000000
26	W100-1000	ST37090	1	1000000	1000000	1000000	1000000	1000000
27	W100-1000	ST37090	1	1000000	1000000	1000000	1000000	1000000
28	W100-1000	ST37090	1	1000000	1000000	1000000	1000000	1000000
29	W100-1000	ST37090	1	1000000	1000000	1000000	1000000	1000000
30	W100-1000	ST37090	1	1000000	1000000	1000000	1000000	1000000
31	W100-1000	ST37090	1	1000000	1000000	1000000	1000000	1000000
32	W100-1000	ST37090	1	1000000	1000000	1000000	1000000	1000000
33	W100-1000	ST37090	1	1000000	1000000	1000000	1000000	1000000
34	W100-1000	ST37090	1	1000000	1000000	1000000	1000000	1000000
35	W100-1000	ST37090	1	1000000	1000000	1000000	1000000	1000000
36	W100-1000	ST37090	1	1000000	1000000	1000000	1000000	1000000
37	W100-1000	ST37090	1	1000000	1000000	1000000	1000000	1000000
38	W100-1000	ST37090	1	1000000	1000000	1000000	1000000	1000000
39	W100-1000	ST37090	1	1000000	1000000	1000000	1000000	1000000
40	W100-1000	ST37090	1	1000000	1000000	1000000	1000000	1000000
41	W100-1000	ST37090	1	1000000	1000000	1000000	1000000	1000000
42	W100-1000	ST37090	1	1000000	1000000	1000000	1000000	1000000
43	W100-1000	ST37090	1	1000000	1000000	1000000	1000000	1000000
44	W100-1000	ST37090	1	1000000	1000000	1000000	1000000	1000000
45	W100-1000	ST37090	1	1000000	1000000	1000000	1000000	1000000
46	W100-1000	ST37090	1	1000000	1000000	1000000	1000000	1000000
47	W100-1000	ST37090	1	1000000	1000000	1000000	1000000	1000000
48	W100-1000	ST37090	1	1000000	1000000	1000000	1000000	1000000
49	W100-1000	ST37090	1	1000000	1000000	1000000	1000000	1000000
50	W100-1000	ST37090	1	1000000	1000000	1000000	1000000	1000000
51	W100-1000	ST37090	1	1000000	1000000	1000000	1000000	1000000
52	W100-1000	ST37090	1	1000000	1000000	1000000	1000000	1000000
53	W100-1000	ST37090	1	1000000	1000000	1000000	1000000	1000000
54	W100-1000	ST37090	1	1000000	1000000	1000000	1000000	1000000
55	W100-1000	ST37090	1	1000000	1000000	1000000	1000000	1000000
56	W100-1000	ST37090	1	1000000	1000000	1000000	1000000	1000000
57	W100-1000	ST37090	1	1000000	1000000	1000000	1000000	1000000
58	W100-1000	ST37090	1	1000000	1000000	1000000	1000000	1000000
59	W100-1000	ST37090	1	1000000	1000000	1000000	1000000	1000000
60	W100-1000	ST37090	1	1000000	1000000	1000000	1000000	1000000
61	W100-1000	ST37090	1	1000000	1000000	1000000	1000000	1000000
62	W100-1000	ST37090	1	1000000	1000000	1000000	1000000	1000000
63	W100-1000	ST37090	1	1000000	1000000	1000000	1000000	1000000
64	W100-1000	ST37090	1	1000000	1000000	1000000	1000000	1000000
65	W100-1000	ST37090	1	1000000	1000000	1000000	1000000	1000000
66	W100-1000	ST37090	1	1000000	1000000	1000000	1000000	1000000
67	W100-1000	ST37090	1	1000000	1000000	1000000	1000000	1000000
68	W100-1000	ST37090	1	1000000	1000000	1000000	1000000	1000000
69	W100-1000	ST37090	1	1000000	1000000	1000000	1000000	1000000
70	W100-1000	ST37090	1	1000000	1000000	1000000	1000000	1000000
71	W100-1000	ST37090	1	1000000	1000000	1000000	1000000	1000000
72	W100-1000	ST37090	1	1000000	1000000	1000000	1000000	1000000
73	W100-1000	ST37090	1	1000000	1000000	1000000	1000000	1000000
74	W100-1000	ST37090	1	1000000	1000000	1000000	1000000	1000000
75	W100-1000	ST37090	1	1000000	1000000	1000000	1000000	1000000
76	W100-1000	ST37090	1	1000000	1000000	1000000	1000000	1000000
77	W100-1000	ST37090	1	1000000	1000000	1000000	1000000	1000000
78	W100-1000	ST37090	1	1000000	1000000	1000000	1000000	1000000
79	W100-1000	ST37090	1	1000000	1000000	1000000	1000000	1000000
80	W100-1000	ST37090	1	1000000	1000000	1000000	1000000	1000000
81	W100-1000	ST37090	1	1000000	1000000	1000000	1000000	1000000
82	W100-1000	ST37090	1	1000000	1000000	1000000	1000000	1000000
83	W100-1000	ST37090	1	1000000	1000000	1000000	1000000	1000000
84	W100-1000	ST37090	1	1000000	1000000	1000000	1000000	1000000
85	W100-1000	ST37090	1	1000000	1000000	1000000	1000000	1000000
86	W100-1000	ST37090	1	1000000	1000000	1000000	1000000	1000000
87	W100-1000	ST37090	1	1000000	1000000	1000000	1000000	1000000
88	W100-1000	ST37090	1	1000000	1000000	1000000	1000000	1000000
89	W100-1000	ST37090	1	1000000	1000000	1000000	1000000	1000000
90	W100-1000	ST37090	1	1000000	1000000	1000000	1000000	1000000
91	W100-1000	ST37090	1	1000000	1000000	1000000	1000000	1000000
92	W100-1000	ST37090	1	1000000	1000000	1000000	1000000	1000000
93	W100-1000	ST37090	1	1000000	1000000	1000000	1000000	1000000
94	W100-1000	ST37090	1	1000000	1000000	1000000	1000000	1000000
95	W100-1000	ST37090	1	1000000	1000000	1000000	1000000	1000000
96	W100-1000	ST37090	1	1000000	1000000	1000000	1000000	1000000
97	W100-1000	ST37090	1	1000000	1000000	1000000	1000000	1000000
98	W100-1000	ST37090	1	1000000	1000000	1000000	1000000	1000000
99	W100-1000	ST37090	1	1000000	1000000	1000000	1000000	1000000
100	W100-1000	ST37090	1	1000000	1000000	1000000	1000000	1000000

The current report chapter is always marked with the special color in the tree. The modification of the current chapter is performed by simply clicking over its name in the tree, upon which, in the right part of the window, the page the selected chapter begins from is chosen to be the currently active page.

In this way, the current chapter in the tree is always synchronized with the display of the current report page, which allows easy positioning in the desired part of the document. Changing the current chapter can be performed by using the cursor arrows.

Changing the current report page can be also performed using the keyboard and the '**PgUp**' and '**PgDn**' buttons, as well as choosing the appropriate icons.



By choosing this icon, the page preceding the currently active page is set for the current page.



By choosing this icon, the page following the currently active page is set for the current page.

In case the document contains a large number of pages, the scroll bar, located beside the right edge of this window, can be used for the purpose of fast setting of the current page.



By choosing this icon, switching to the simultaneous display of several report pages on the screen is made possible. The number of pages being simultaneously displayed is being chosen from the combo box, that is activated by clicking on the arrow on the right side of the icon. The program limits the possible number of displayed pages to 6.



By choosing this icon, the return to the display of only one - current page of the report

The zooming is possible by rotating the mouse wheel or using some of the special commands:

- **CTRL + left mouse button** = Zoom window. While holding down the 'CTRL' button, clicking the left mouse button will select the chosen point as the first corner of the rectangular area that is to be enlarged, and the next click on the left mouse button will understand the chosen point as the opposite corner of the rectangular area, and the enlargement will be performed.
- **CTRL + middle mouse button** = Zoom all.
- **CTRL + right mouse button** = Zoom previous.
- Moving the appearance of the page display is performed by clicking on the middle mouse button and moving it.

Also, the zooming commands can be activated by choosing the appropriate icon:

 - Zoom all

 - Zoom window

 - Zoom previous

 - Zoom dynamic

 - Zoom pan

13.2 Report formatting

The program 'Metal Studio' allows the adjustment of a large number of parameters, associated to the appearance and contents of the project documentation being created, with the purpose of better accommodation to various needs and customs of the user.

All the adjustment of the appearance and contents of the report are being performed within the dialog box, which opens up upon activation of the '**Report formatting**' command, using the icon .

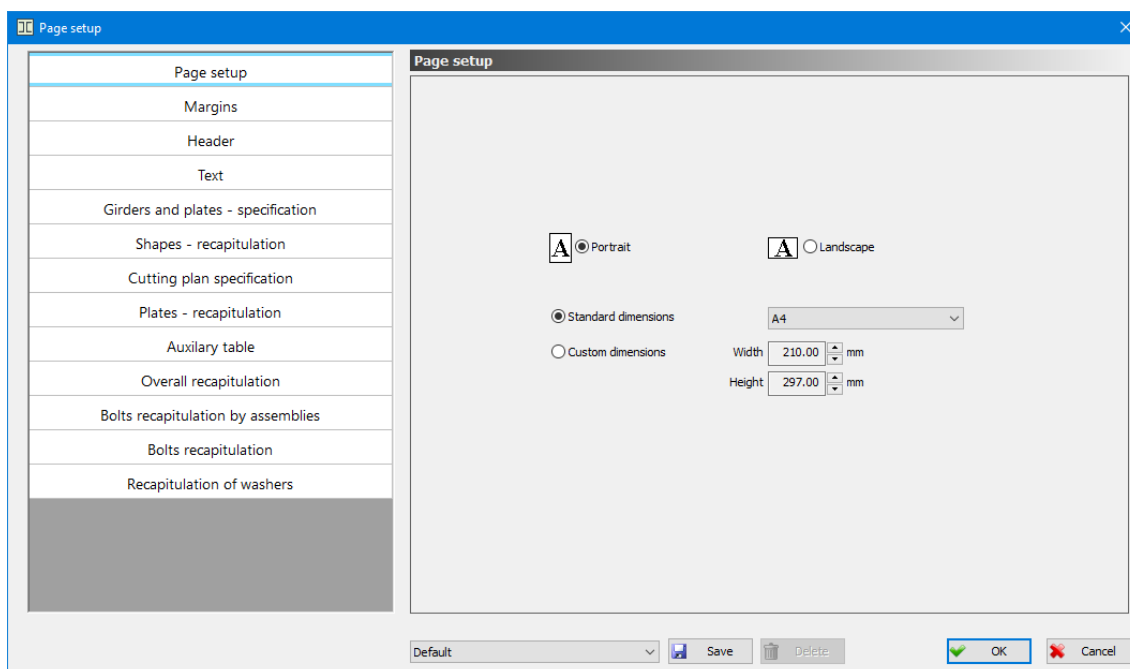

The dialog box for formatting the report - the layout

Due to the large amount of data, this dialog is organized across pages. The left part of the dialog shows a list of all pages, while the right part shows the content of the currently active page.

The current state of the parameters set in the dialog can be recorded in the configuration. By selecting from the list, any of the previously recorded configurations can be set as the current one.



Save

The configuration with the current state of parameters in the dialog box is saved in the database.



Delete

Deleting the current configuration from the database.

13.2.1 Page setup

Within the '**Page setup**' page, you have the option to define the size of the document page.

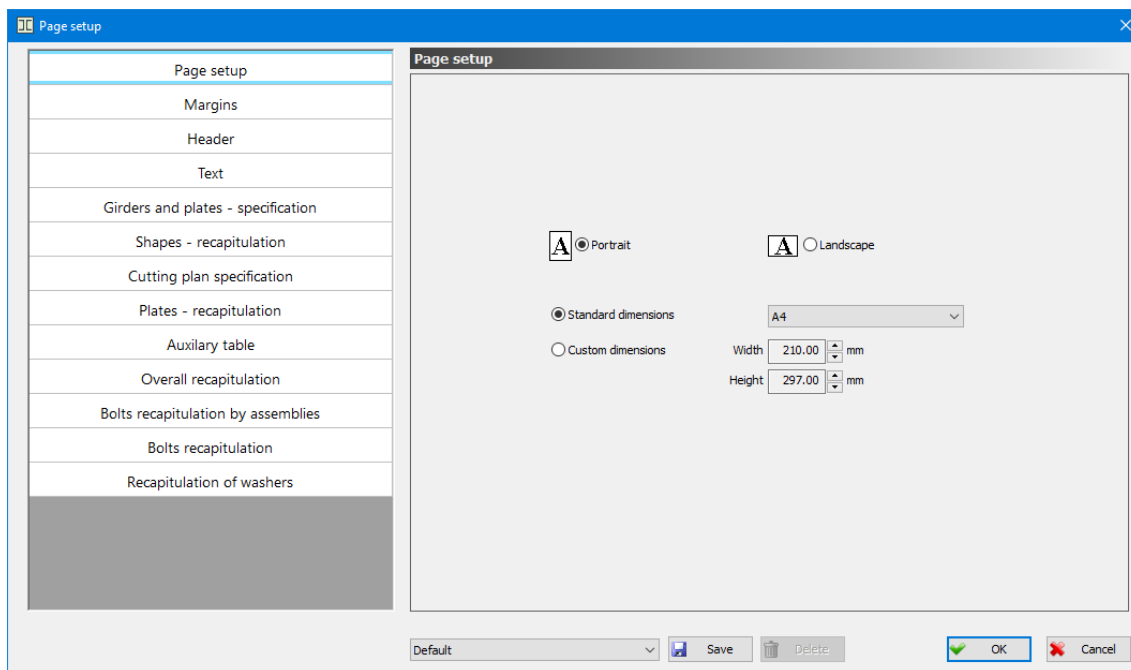

'Page setup' page - the layout

Standard dimensions

The switch whose activation in the combo box to its right allows you to choose one of the given paper formats.

Custom dimensions

The switch whose activation allows you to assign completely arbitrary paper dimensions in the '**Width**' and '**Height**' edit boxes. It is obligatory that your output printing device supports the given paper format.

Portrait

The switch whose activation results in the vertical orientation of the paper.

Landscape

The switch whose activation results in the horizontal orientation of the paper.

13.2.2 Margins

Within the '**Margins**' page, the net area of the paper for printing is defined.

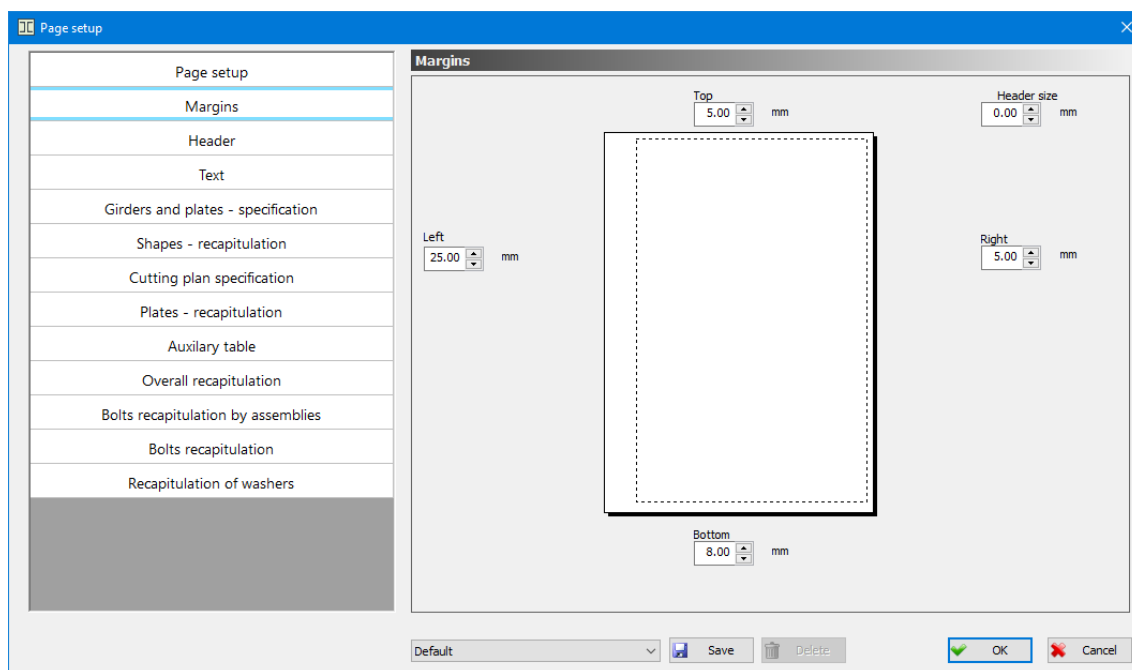

'Margins' page - the layout

The chosen paper format is displayed in the center part of the dialog box, with the possibility to define specific margins in the appropriate edit boxes. You must pay attention while assigning these values, due to the fact that every output device has a limitation considering the net printing surface. Within this procedure, the program will allow the assigning completely arbitrary value, but during the printing of the document, it is possible that the driver fails to print in that part of the edge area. In such case, upon printing request, the program will issue an appropriate warning.

- Top** The edit box for entering the size of the upper margin.
- Bottom** The edit box for entering the size of the bottom margin. The minimum value set by the program is 8mm, considering the fact that the author's signature must be included in the footer of every paper.
- Left** The edit box for entering the size of the left margin.
- Right** The edit box for entering the size of the right margin.
- Header size** The edit box for entering the header height. In case the document is not supposed to contain the header, you should enter the value '0' in this box.

13.2.3 Header

Within the '**Header**' page, the layout of the header that will be printed at the top of each page of the document is defined.

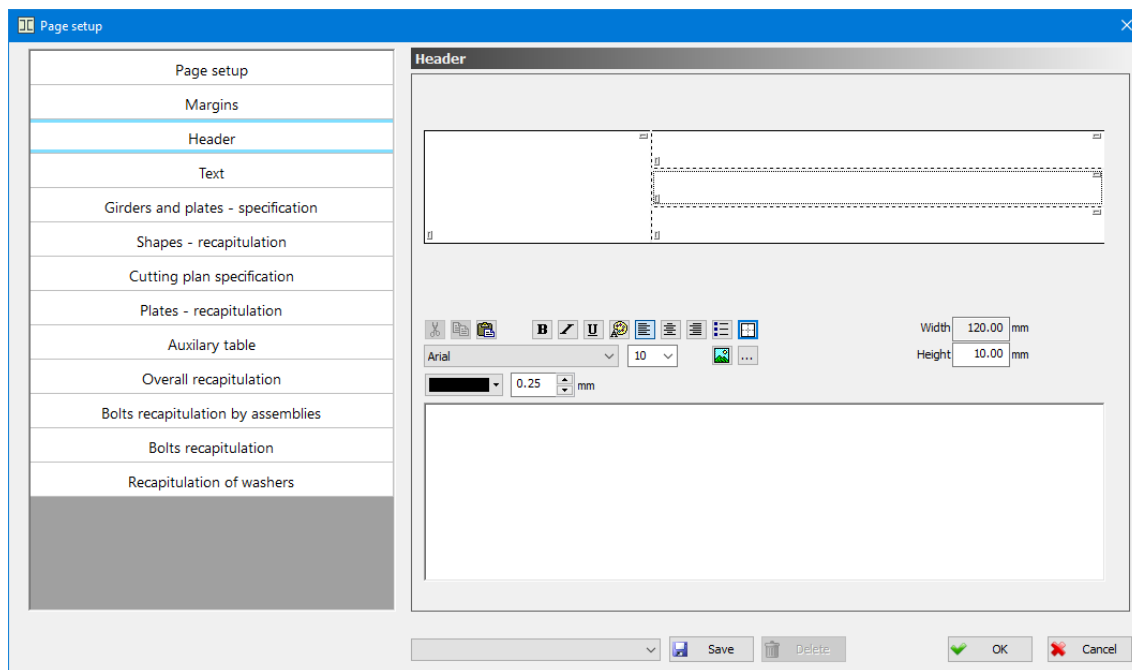

'Header' page - the layout

The current appearance of the created header is displayed in the upper part of the dialog box. The header table is divided into multiple cells (rectangular areas), and by clicking each of them, the contents of the currently active cell will be displayed in the bottom part of the dialog box.

In the bottom left corner of each of the cells there is a small vertical rectangle, which can help dividing vertically each of the cells into two new cells. Small horizontal rectangle in the top right corner of each of the cells has the purpose of dividing horizontally the cells. By bringing the mouse pointer in the position of pointing towards one of these two small rectangles, the cursor changes the shape into the appropriate shape that is, at the same time, indicating the purpose of possible activity.

The operation of cell dividing is performed by clicking on the desired small rectangle with the mouse pointer, and, while holding it, bringing it in the position of the desired vertical, or horizontal division. Also, on the newly added cell, in the bottom left corner, as well as in the top right corner, there are small rectangles for its possible division into smaller components.

Into each of the cells, a completely arbitrary contents can be entered. Choice and size of the font is performed from the combo boxes located above the box provided for editing the contents of the currently active cell.

Height

The edit box for entering the height of each of the header cells. By clicking on any of the cells, it becomes currently active, and its current dimension is displayed in the edit box. Since the header has the limited, previously assigned dimension, the change of the dimensions of one cell will effect the dimensions of all the other cells. It is accepted that the change of the dimensions of the cells is conducted from left right, from top to bottom. In relation to that, selection one of the edge cells will result in edit box for numerical adjustment of the dimensions being inactive.

Width

The edit box for entering the width of each of the header cells. Everything that has been previously stated for entering the height of each of the header cells will also apply to entering the width.



The selected text is moved from the cell to the clipboard.



The selected text is moved to the clipboard, but also stays in the cell.



The previously placed text in the 'clipboard' is moved to the cell, to the spot specified by the current cursor position.



The icon whose activation results in the bold listing of the selected text.



The icon whose activation results in the italic listing of the selected text.



The icon whose activation results in the underlined listing of the selected text.



Choosing this icon results in the opening of the drop-down menu for selecting the color that will be attached to the selected text.



The icon whose activation results in the left alignment of the selected text.



The icon whose activation results in the center alignment of the selected text.



The icon whose activation results in the right alignment of the selected text.



Choosing this icon results in marking the selected text as the option in the multiple data list.



Choosing this icon results in the opening of the dialog box for setting the frame around the cell.

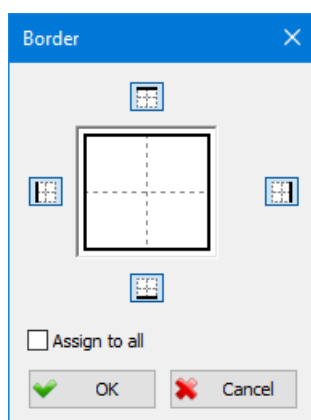

The dialog box for setting the frame around the cell



– frame line is set on the top side of the cell.



– frame line is set on the bottom side of the cell.



– frame line is set on the left side of the cell.



– frame line is set on the right side of the cell.

Assign to all – The switch whose activation results in the possibility of assign the chosen sides for setting the frame to all the other cells in the header.



Choosing this icon results in the opening of the dialog box for loading the pictures from the computer drive.

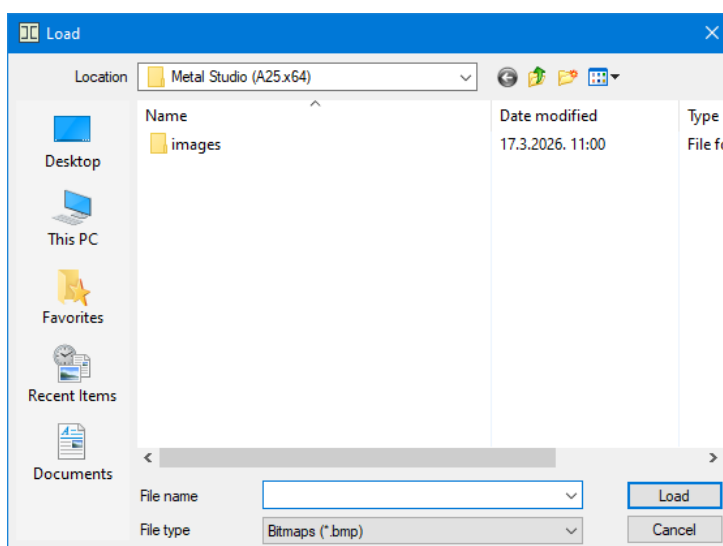

The dialog box for loading the pictures into the header cell

File type The combo box for choosing the file type ('*.bmp', '*.wmf' and '*.emf').

Upon selecting the desired file and activating the '**Load**' button, the contents of the loaded picture will appear on the cursor position. In case the picture format is large, click on it with the mouse pointer, and, using the scroll bar, bring one of its corners to the position where it can be seen in the area provided for the cell display.



Choosing this icon results in the opening of the drop-down menu for the automatic inserting of the texts defined by the program. The following texts are available:

#p - Current page number
 #n - Total number of pages
 #t - Current time
 #d - Current date

13.2.4 Text

Within the **'Text'** page, you have the possibility to define all the data about the type, color and size of the texts that are printed on the paper.

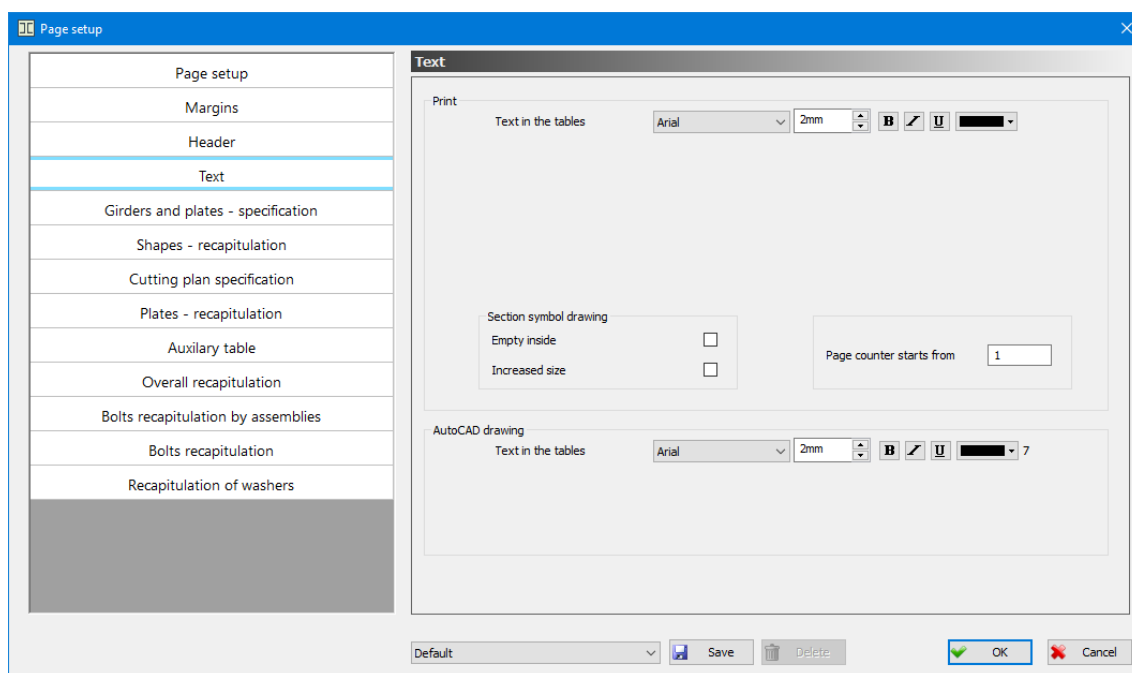

'Text' page - the layout

Print

This part of the dialog box contains the parameters for defining the report appearance during the printing.

Text in the tables

Applies on all the texts in all the reports. It is possible to choose the font, height, thickness, skew, underline and the color of the text.

Section symbol drawing

The user is allowed to alter the size and mode of displaying the symbols of shapes and plates, which will be presented in the appropriate tables, in the 'Description' column.

Empty inside - The check box whose activation indicates that the section symbols will be displayed without the pattern, i. e. their interior will be empty.

Increased size - The check box whose activation indicates that the section symbols will be displayed enlarged.

Page counter starts from

In this edit box, the number the program starts the report numeration from, can be assigned.

AutoCAD drawing

This part of the dialog box allows defining of the parameters for the report, that will be exported to the 'AutoCAD' drawing. The sizes of the texts will be calculated in relation to the current scale of drawing.

Text in the tables

Applies to all the texts in all the reports that will be exported to the drawing. It is possible to choose the font, height, thickness, skew, underline and the color of the text.

13.2.5 Girders and plates - specification

Within the page 'Girders and plates - specification' it is possible to define all parameters related to the report (table) of the same name.

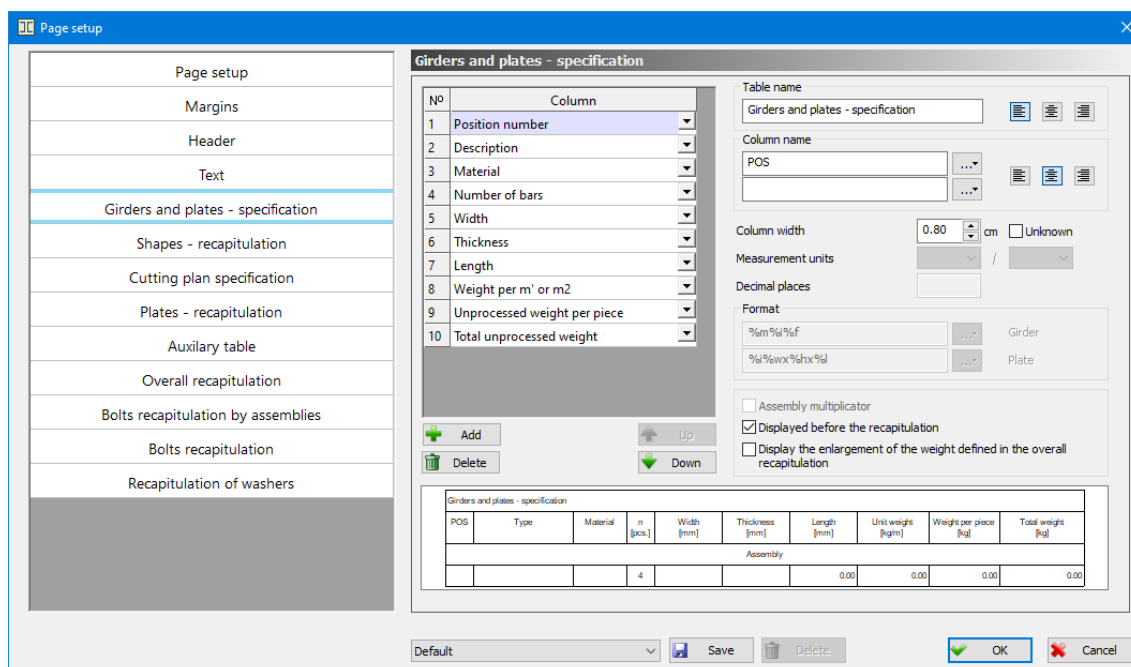

'Girders and plates - specification' page - the layout

Table name The edit box for entering the title that will be written in the beginning of each of the tables. The position of the title text (in the horizontal direction) is possible to be adjusted by choosing one of three alignment methods (left, center, right).



The icon whose activation results in the left alignment of the title text.



The icon whose activation results in the center alignment of the title text.



The icon whose activation results in the right alignment of the title text.

In the top left part of the dialog box there is a list defining the order and the contents of the columns forming this report. The contents of each column can be adjusted by choosing from the combo box that opens up by clicking the arrow on the right side of the column.

For each of the report columns it is possible to define:

- text that will be written in the header
- column width
- data that is specific for that column

Column name The edit box for entering the text that will be written in the head of the chosen column. It is allowed to define two rows of the text. The alignment assignment (right, center, left) is being performed in the same manner as in previously explained case of the 'Table name' edit box.



The button whose activation results in the opening of the drop-down menu that contains the option '%%c – label for diameter', which allows the appearance of the special symbol 'Ø' within the text.

Column width The edit box for entering the data about the requested column width. The column can also have the unknown width. In that case, its width is being defined in the manner that it corresponds to the available width on the paper, that is left after the subtraction of widths of the columns with known width. In case several columns has the unknown width, the available width on the paper will be equally allocated to of them.

Unknown The check box whose activation results in the column having an unknown width (explained in the option 'Column width').

Displayed before the recapitulation

The check box whose activation results in the specification report of the girders and plates being in front of the recapitulation report.

Display the enlargement of the weight defined in the overall recapitulation

When this check box is on, the enlargement of the weight is displayed in the specification report, with the parameters defined in the 'Overall recapitulation' tag.

 **Add**

The button whose activation results in inserting a new column.

 **Delete**

The button whose activation results in deleting the currently selected column.



The button whose activation results in moving the currently selected column (upwards).



The button whose activation results in moving the currently selected column (downwards).

The layout of the table corresponding to the current state of parameters is displayed in the bottom part of the dialog box.

This report can be created as a combination of the following columns:

Position number

The column where the ordinal number of the positions of the girders and plates is written.

Description

The column where the description of the positions included in the report is defined. Specific data for this column are the edit boxes where the description contents is entered:

Girder - The edit box where the description contents of the girders is defined. By activating this button, which is in the continuation of this edit box, a drop-down menu for the selection of the parameters that can be displayed in the girder description will open up. In the continuation of the symbol of each of the parameters, there is a short text, clearly indicating what the given parameter represents. The selection of the desired parameter is performed by clicking, upon which the program closes the drop-down menu, and places the selected parameter in the edit box. You can assign all these parameters directly in the edit box, by entering their symbol, using the keyboard. You can adjust the manner of drawing the girder symbol that can be found in this column, by selecting from the drop-down menu, in the 'Text' tag (see Chapter 13.2.4).

Plate - The edit box for defining the plate descriptions. Entering the description in this edit box is the same as in the case of assigning the girder descriptions, and therefore will not be explained again.

<u>Material</u>	The column where the steel type is written.
<u>Number of bars</u>	The column where the total quantity of girders or plates of the selected positions is written. The specific data for this column is: Assembly multiplier - when this check box is not active, the total quantity of girders and plates of the selected position is displayed, and with this check box active, the quantity is displayed in the format 'given quantity for the current array (see Chapter '2.1') x given quantity of girders and plates of the selected position'.
<u>Type of shape</u>	The column where the type, tag and length of the position of the girder, or the width and length of the position of the plate is written.
<u>Width</u>	The column where the plate width is written. For the girder positions, this column will be empty. Specific data for this column is: Measurement units - for defining the units of measurement for the layout. Decimal places - for defining the maximum number of the decimal places that will be used for the writing.
<u>Length</u>	The column where the girder length of one girder, or plate length is written. Specific data for this column is: the units of measurement and the number of decimal places.
<u>Thickness</u>	The column where the plate thickness is written. For the girder positions, this column will be empty. Specific data for this column is: the units of measurement and the number of decimal places.
<u>Comment</u>	The column where the position comment is written.
<u>Specific weight</u>	The column where the specific weight of steel for the girders, or plates is written. Specific data for this column is: the units of measurement and the number of decimal places.
<u>Processed weight per piece</u>	The column where the real weight of the position of the girder or plate, by the piece, is written (taking into account both the formings of the girder ends, and the holes in the girders and plates, but excluding holes from the bolt series). Specific data for this column is: the units of measurement and the number of decimal places.
<u>Unprocessed weight per piece</u>	The column where the weight of the position of the girder or plate, by the piece, is written (not taking into account neither the formings of the girder ends, nor the holes in the girders and plates). Specific data for this column is: the units of measurement and the number of decimal places.
<u>Processed area of surface per piece</u>	The column where the real surface for coloring the position of the girder or plate, by the piece, is written (taking into account both the formings of the girder ends and the holes in the girders and plates, but excluding the holes from the bolt series). Specific data for this column is: the units of measurement and the number of decimal places.

Unprocessed area of surface per piece

The column where the surface for coloring the position of the girder or plate, by the piece, is written (not taking into account neither the formings of the girder ends, nor the holes in the girders and plates). Specific data for this column is: the units of measurement and the number of decimal places.

Total length

The column where the sum of lengths of all the girders in the position. Specific data for this column is: the units of measurement and the number of decimal places.

Weight per m' or m2

The column where the unit weight of the girder or plate, i.e. the data about the weight of the girder of unit length and the weight of the plate by m2 is written. Specific data for this column is: the units of measurement and the number of decimal places.

Total processed weight

The column where the total real weight of all the girders and plates of the selected position is written (taking into account both the formings of the girder ends and the holes in the girders and plates, but excluding the holes from the bolt series). Specific data for this column is: the units of measurement and the number of decimal places.

Specific for this column is that at the end of each whole, the sum of complete column is written.

Total unprocessed weight

The column where the total weight of all the girders and plates of the selected positions is written (not taking into account neither the formings of the girder ends, nor the holes in the girders and plates). Specific data for this column is: the units of measurement and the number of decimal places.

Specific for this column is that at the end of each whole, the sum of complete column is written.

Total processed area of surface

The column where the total real surface for coloring all the girders or plates of the selected position is written (taking into account both the formings of the girder ends and the holes in the girders and plates, but excluding the holes from the bolt series). Specific data for this column is: the units of measurement and the number of decimal places.

Specific for this column is that at the end of each whole, the sum of complete column is written.

Total unprocessed area of surface

The column where the total surface for coloring all the girders or plates of the selected position is written (not taking into account neither the formings of the girder ends, nor the holes in the girders and plates). Specific data for this column is: the units of measurement and the number of decimal places.

Specific for this column is that at the end of each whole, the sum of complete column is written.

Grouping of columns

If the mouse pointer is placed above the name of some column of the report in the list, and the right button is clicked, the dialog box which permits grouping of columns of the current report will open up.

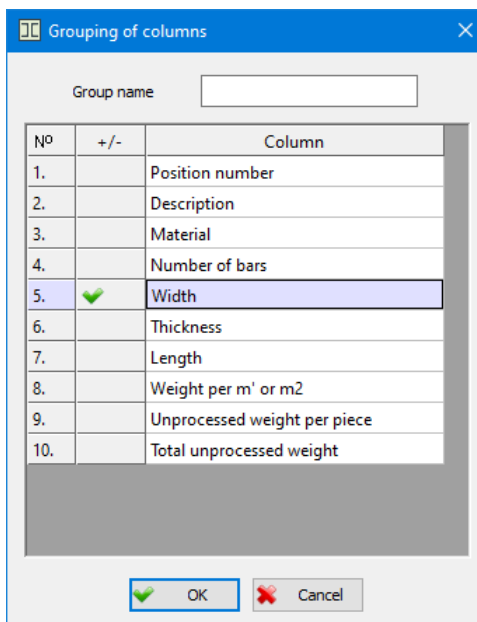

Report column above which the mouse was positioned during the dialog box opening, must be a part of the group of columns being created, and in front of its name in the table, there is the ✓ sign.

Group name Name of the group being created is entered in this box. That name will be displayed in the report.

Report columns are assigned to the group by placing the mouse pointer above them, and then clicking the left button, after which the ✓ sign appears in front of their name. During the choosing of columns, the only condition is that these columns are located near some of the previously chosen columns, in the table.

Upon selecting the 'OK' button, the program returns to the base dialog box for report formatting.

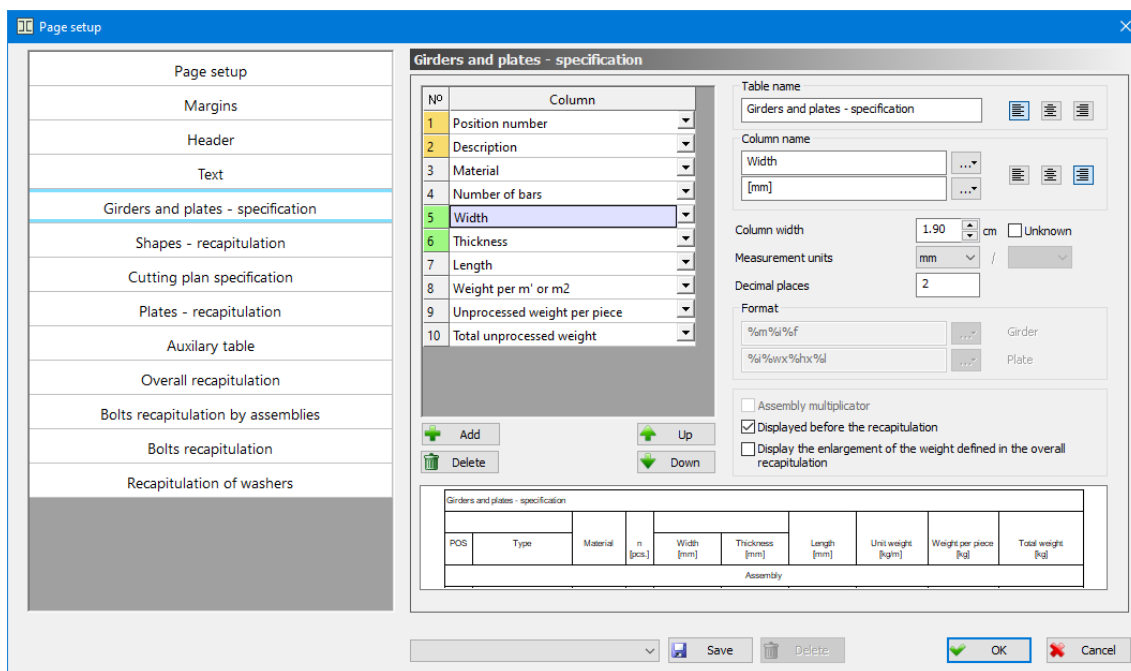

In this way, arbitrary number of report column groups may be created. All the columns belonging to some group from the list are marked with special color.

In the report table, in the row with the column names, for all the columns belonging to the group, the program enters the shared cell, where the assigned group name is displayed.

Editing of the report column groups is performed in the exact way as their creating.

13.2.6 Shapes - recapitulation

Within the '**Shapes - recapitulation**' page, it is possible to define all parameters related to the report (table) of the same name.

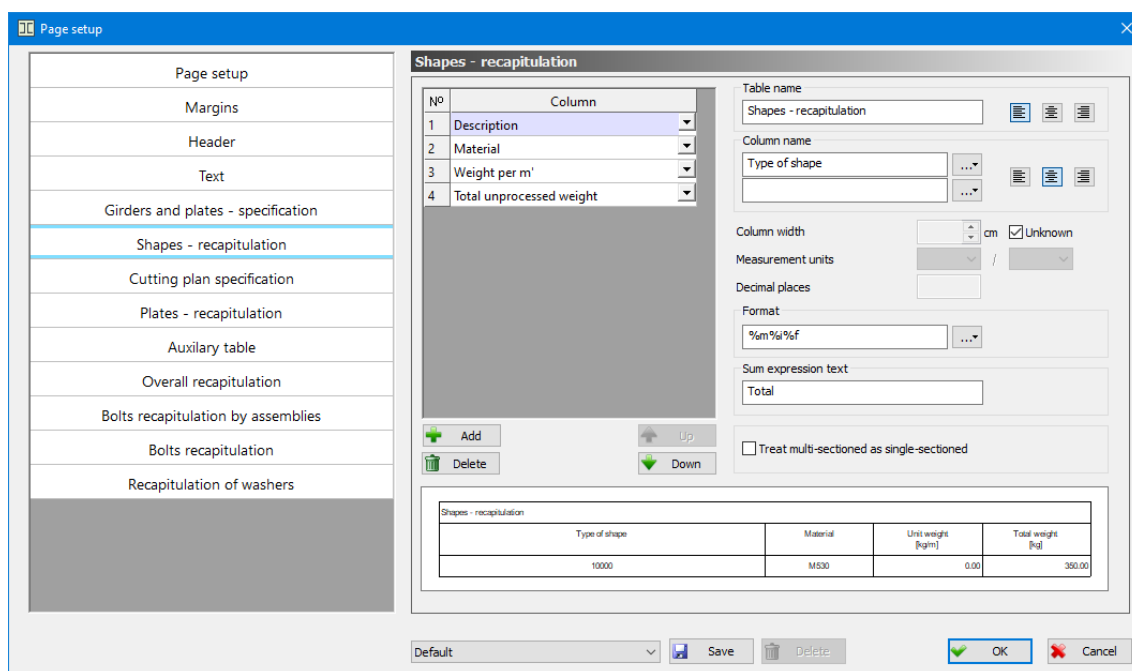

'Shapes - recapitulation' page - the layout

The data related both to the '**Table name**' and the general data of all the columns ('**Column name**' and '**Column width**') is completely identical with the previously described tag, and therefore will not be explained again.

Treat multi-sectioned as single-sectioned

The check box whose activation results in the girders with the multi-part sections be displayed with their description and unit weight as one-parted, whereas the total lengths, surfaces for coloring and weights will be multiplied by the number of shapes in the section.

Sum expression text

The edit box for defining the arbitrary text, which will be displayed at the end of each of the wholes, in the row where the sums of the columns are.

This report can be created as a combination of the following columns:

Material The column where the steel type is written.

Description The column for specifying description of the girders that are to be placed within the report. Specific data for this column is the edit box for entering the contents

of the description text. By clicking the button, which is in the continuation of this edit box, a drop-down menu for the selection of the parameters that can be displayed in the girder description will open up. In the continuation of the symbol of each of the parameters, there is a short text, clearly indicating what the given parameter represents. You can adjust the manner of drawing the girder symbol that can be found in this column, by selecting from the drop-down menu, in the 'Text' tag (see Chapter 13.2.4).

Specific weight The column where the specific weight of steel for the girders is written. Specific data for this column is: the units of measurement and the number of decimal places.

Weight per m' The column where the unit weight of the girder, i.e. the data about the weight of the girder of unit length is written. Specific data for this column is: the units of measurement and the number of decimal places.

Total processed weight The column where the total real weight of all the girders of the selected position is written (taking into account both the formings of the girder ends and the holes in the girders, but excluding the holes from the bolt series). Specific data for this column is: the units of measurement and the number of decimal places. Specific for this column is that at the end of each whole, the sum of complete column is written.

Total unprocessed weight The column where the total weight of all the girders of the selected position is written (not taking into account neither the formings of the girder ends, nor the holes in the girders). Specific data for this column is: the units of measurement and the number of decimal places. Specific for this column is that at the end of each whole, the sum of complete column is written.

Total processed area of surface The column where the total real surface for coloring all the girders of the selected position is written (taking into account both the formings of the girder ends and the holes in the girders, but excluding the holes from the bolt series). Specific data for this column is: the units of measurement and the number of decimal places. Specific for this column is that at the end of each whole, the sum of complete column is written.

Total unprocessed area of surface The column where the total surface for coloring all the girders of the selected position is written (not taking into account neither the formings of the girder ends, nor the holes in the girders). Specific data for this column is: the units of measurement and the number of decimal places. Specific for this column is that at the end of each whole, the sum of complete column is written.

Total length The column where the sum of all lengths of the girders of same type. Is written. Specific data for this column is: the units of measurement and the number of decimal places.

13.2.7 Plates - recapitulation

Within the page '**Plates - recapitulation**' it is possible to define all the parameters related to the report (table) of the same name.

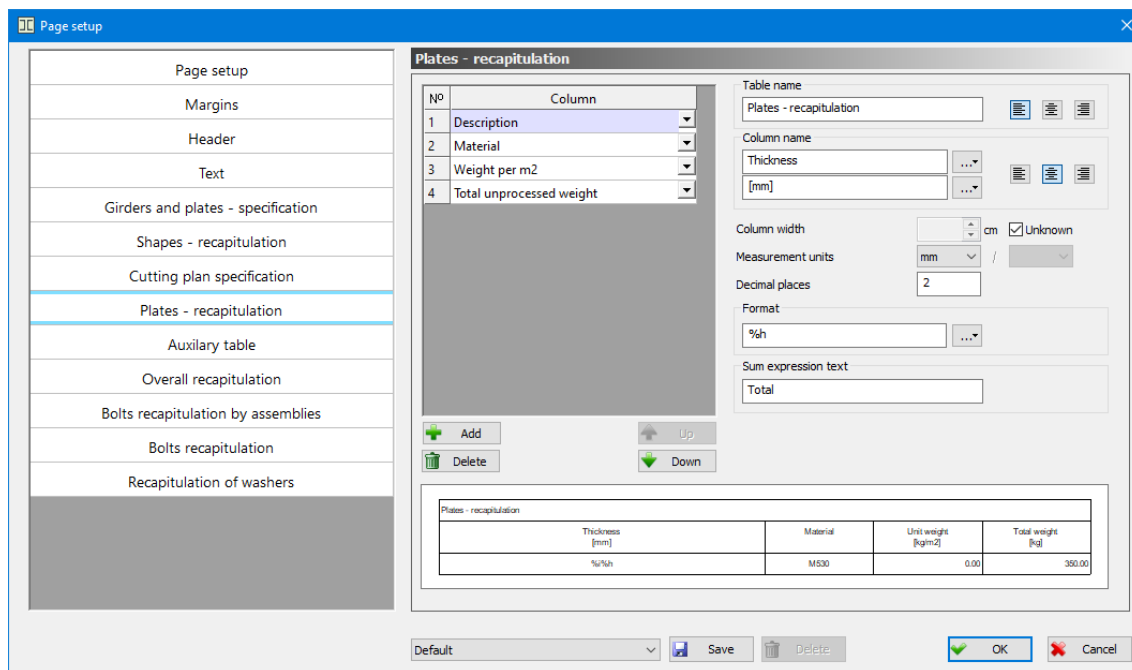

'Plates - recapitulation' page - the layout

This report can be created as a combination of the following columns:

- Material** The column where the steel type is written.
- Description** The column for specifying description of the plates that are to be placed within the report. Specific data for this column is the edit box for entering the contents of the description. By clicking the button, which is in the continuation of this edit box, a drop-down menu for the selection of the parameters that can be displayed in the plate description will open up. In the continuation of the symbol of each of the parameters, there is a short text, clearly indicating what the given parameter represents. You can adjust the manner of drawing the plate symbol that can be found in this column, by selecting from the drop-down menu, in the 'Text' tag (see Chapter 13.2.4).
- Thickness** The column where the plate thickness is written. Specific data for this column is: the units of measurement and the number of decimal places.
- Specific weight** The column where the specific weight of steel for the plates is written. Specific data for this column is: the units of measurement and the number of decimal places.
- Weight per m2** The column where the unit weight of the plate, i.e. the data about the weight of the plate per m2 is written. Specific data for this column is: the units of measurement and the number of decimal places.
- Total processed weight** The column where the total real weight of all the plates of the selected position is written (taking into account the holes in the plates, but excluding the holes

from the bolt series). Specific data for this column is: the units of measurement and the number of decimal places.

Specific for this column is that at the end of each whole, the sum of complete column is written.

Total unprocessed weight

The column where the total weight of all the plates of the selected position is written (not taking into account neither the holes in the plates). Specific data for this column is: the units of measurement and the number of decimal places. Specific for this column is that at the end of each whole, the sum of complete column is written.

Total processed area of surface

The column where the total real surface for coloring all the plates of the selected position is written (taking into account the holes in the plates, but excluding the holes from the bolt series). Specific data for this column is: the units of measurement and the number of decimal places.

Specific for this column is that at the end of each whole, the sum of complete column is written.

Total unprocessed area of surface

The column where the total surface for coloring all the plates of the selected position is written (not taking into account the holes in the plates). Specific data for this column is: the units of measurement and the number of decimal places.

Specific for this column is that at the end of each whole, the sum of complete column is written.

13.2.8 Overall recapitulation

Within the '**Overall recapitulation**' page, it is possible to define all parameters related to the report (table) of the same name.

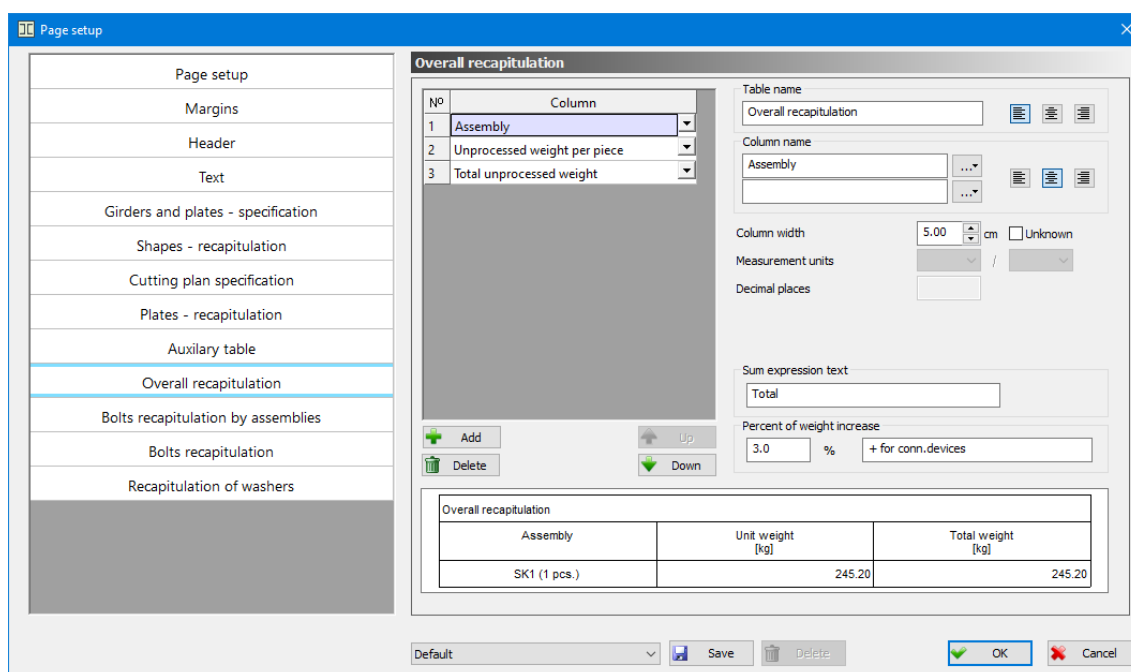

'Overall recapitulation' page - the layout

Percent of the weight increase

Neither the bolt weights nor the weld weights are calculated, but their contribution to the total weight is expressed as the percent increase, and the user is allowed to enter that percentage in the appropriate edit box. An arbitrary text can be entered in the edit box, located on the right of this edit box, and it will be displayed in the row where the total weight with the included percentage of the increase is displayed.

The report is grouped per assembly positions and it can be created as a combination of the following columns:

Assembly The column where the names of the assembly positions are written.

Total processed weight
The column where the total real weight of all the girders and plates of the selected array position is written (taking into account both the formings of the girder ends and the holes in the girders and plates, but excluding the holes from the bolt series). Specific data for this column is: the units of measurement and the number of decimal places.

Total unprocessed weight
The column where the total weight of all the girders and plates of the selected assembly positions is written (not taking into account neither the formings of the girder ends, nor the holes in the girders and plates). Specific data for this column is: the units of measurement and the number of decimal places.

Total processed area of surface
The column where the total real surface for coloring all the girders or plates of the selected assembly position is written (taking into account both the formings of the girder ends and the holes in the girders and plates, but excluding the holes from the bolt series). Specific data for this column is: the units of measurement and the number of decimal places.

Total unprocessed area of surface
The column where the total surface for coloring all the girders or plates of the selected array position is written (not taking into account neither the formings of the girder ends, nor the holes in the girders and plates). Specific data for this column is: the units of measurement and the number of decimal places.

13.2.9 Bolts recapitulation by assemblies

Within the '**Bolts recapitulation by assemblies**' page, it is possible to define all parameters related to the report (table) of the same name.

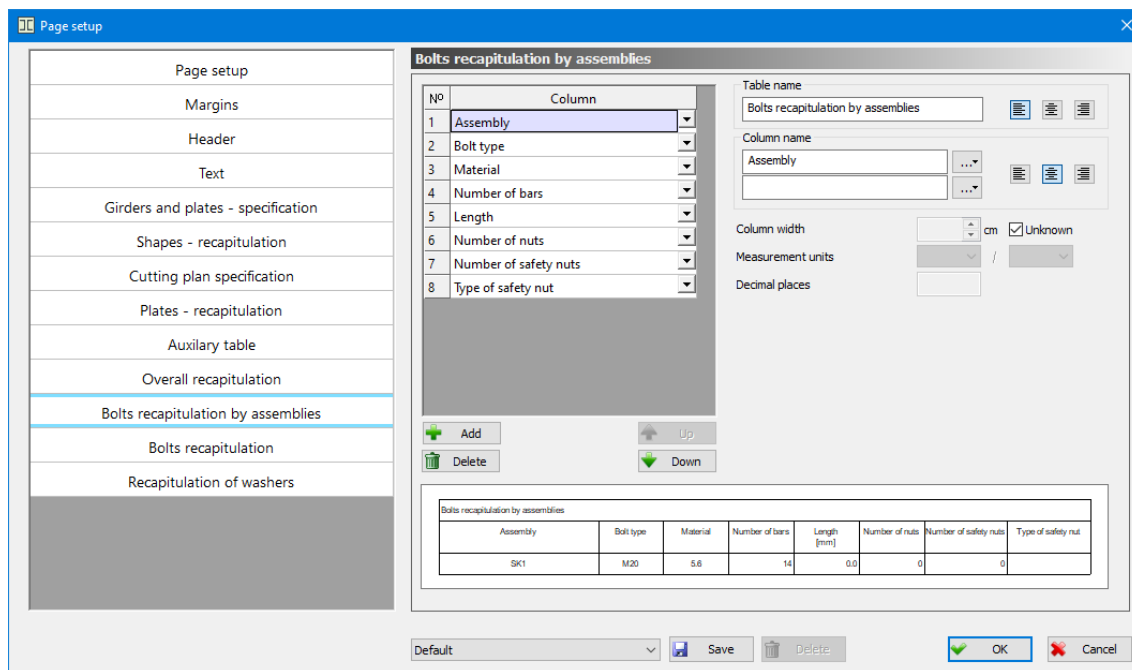

'Bolts recapitulation by assemblies' page - the layout

This report can be created as a combination of the following columns:

Assembly The column where the names of the assembly positions are written.

Material The column where the steel type is written.

Bolt type The column where the bolt type of the selected assembly position is written.

Length The column where the length of a specific bolt type of the selected assembly position is written. Specific data for this column is: the units of measurement and the number of decimal places.

Number of bars The column where the quantity of the bolts of a specific type and length of the selected assembly position is written.

Number of nuts The column where the quantity of the nuts for the bolt of a specific type and length of the selected assembly position is written.

Number of safety nuts The column where the quantity of the safety nuts for the bolt of a specific type and length of the selected assembly position is written.

Type of safety nut The column where the type of the safety nuts for the bolt of a specific type and length of the selected assembly position is written. This data is set within the dialog box for the bolt accessories in the 'Description' edit box, and in case it is not set, the program will automatically generate the name including the dimensions of the safety nut.

13.2.10 Bolts recapitulation

Within the '**Bolts recapitulation**' page, it is possible to define all parameters related to the report (table) of the same name.

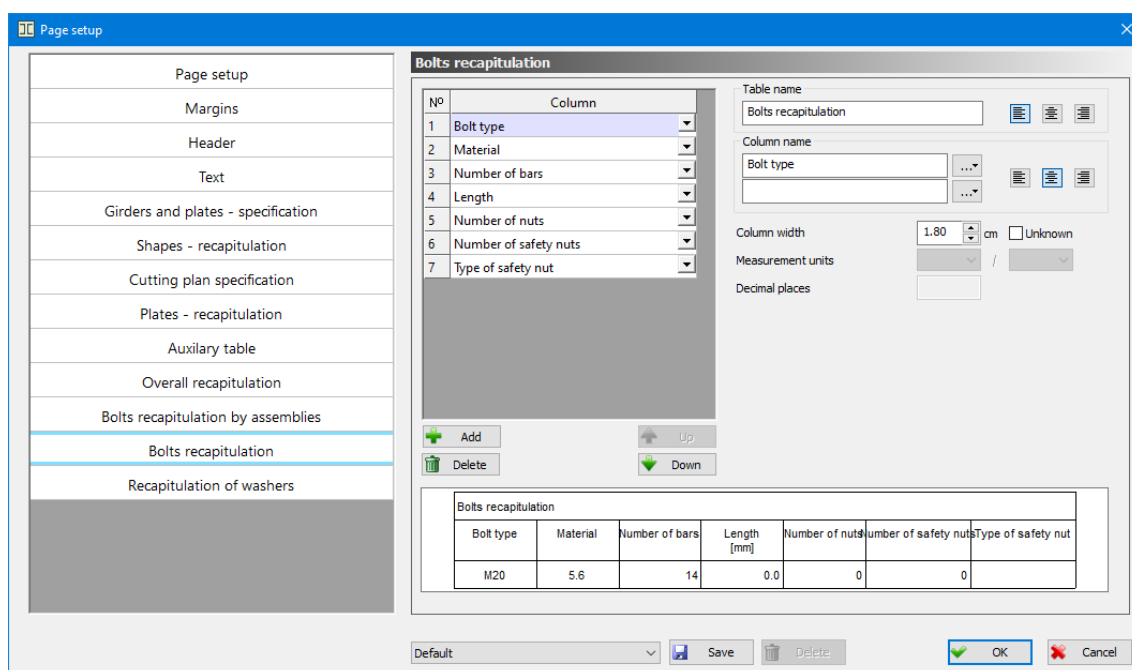

'Bolts recapitulation' page - the layout

This report can be created as a combination of the following columns:

Material The column where the steel type is written.

Bolt type The column where the bolt type is written.

Length The column where the length of a specific bolt type is written. Specific data for this column is: the units of measurement and the number of decimal places.

Number of bars The column where the quantity of the bolts of a specific type and length is written.

Number of nuts The column where the quantity of the nuts for the bolt of a specific type and length is written.

Number of safety nuts The column where the quantity of the safety nuts for the bolt of a specific type and length is written.

Type of safety nut The column where the type of the safety nuts for the bolt of a specific type and length is written. This data is set within the dialog box for the bolt accessories in the 'Description' edit box, and in case it is not set, the program will automatically generate the name including the dimensions of the safety nut.

13.2.11 Recapitulation of the washers

Within the page '**Recapitulation of the washers**', it is possible to define all parameters related to the report (table) of the same name.

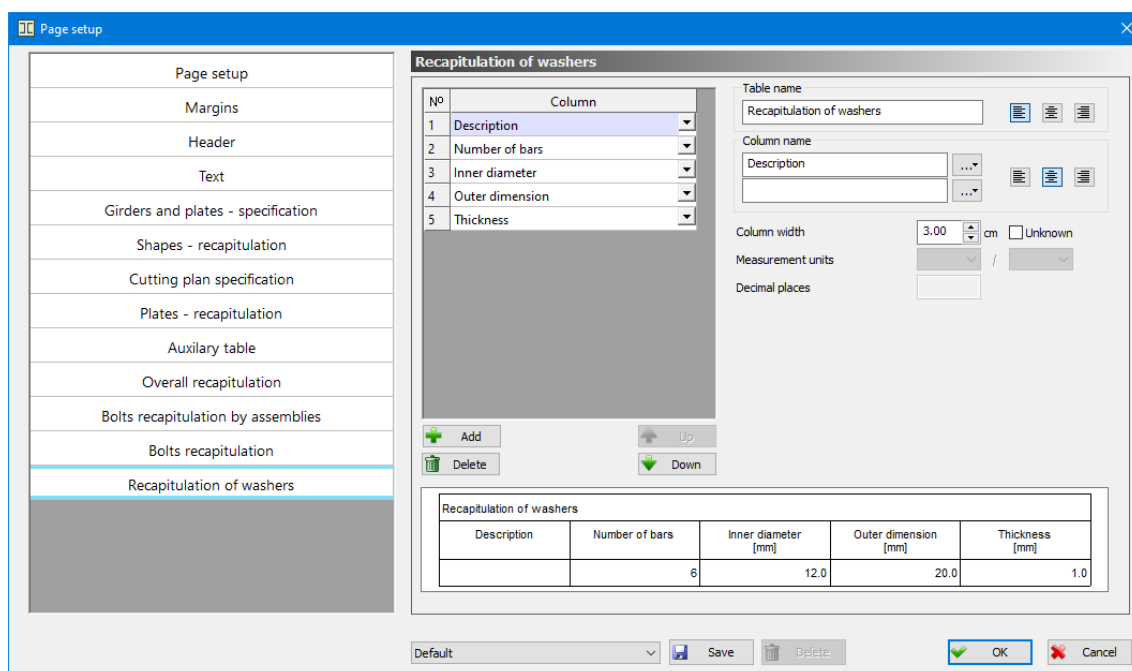

'Recapitulation of the washers' page - the layout

This report can be created as a combination of the following columns:

Description The column where the washer description is written. This data is set within the dialog box for the bolt accessories in the 'Description' edit box, and in case it is not set, the program will automatically generate the name including the dimensions of the washer.

Inner diameter The column where the hole diameter of the washer is written. Specific data for this column is: the units of measurement and the number of decimal places.

Outer dimension The column where the outer dimension of the washer is written. Specific data for this column is: the units of measurement and the number of decimal places.

Thickness The column where the washer thickness is written. Specific data for this column is: the units of measurement and the number of decimal places.

Number of bars The column where the quantity of the selected washer is written.

13.2.12 Auxiliary table

Within the '**Auxiliary table**' page, it is possible to define all parameters related to a table of arbitrary shape and content. The table is an integral part of the profile recapitulation report. Defining and displaying this table is optional.

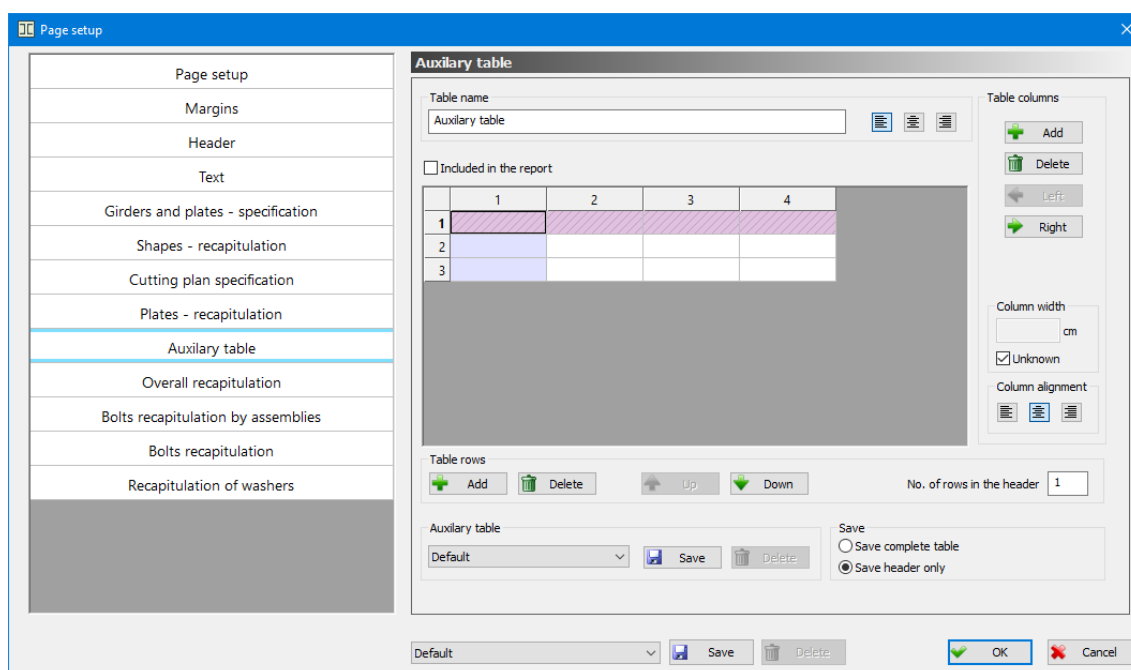

'Auxiliary table' page - the layout

Table name The edit box for entering an arbitrary text that will be written as the title, in the beginning of each of the tables. The position of the title text (in the horizontal direction) is possible to be adjusted by choosing one of three alignment methods (left, center, right).



The icon whose activation results in the left alignment of the title text.



The icon whose activation results in the center alignment of the title text.



The icon whose activation results in the right alignment of the title text.

Included in the report

Check box that specifies whether this table is going to be displayed. By activating this check box, the additional table will be displayed in the report.

The table can have an arbitrary number of rows and columns.

For working with the table columns, there are the command boxes in the '**Table columns**' group:

Add

Inserting a new column at the end of the table. The contents of the new column will be copied from the previously active column.

Delete

Deleting the active column.

Left

Moving the active column to the left.

Right

Moving the active column to the right.

Column width The edit box for entering the data about width of the active column. The column can also have the unknown width. In that case, its width is being defined in the manner that it corresponds to the available space on the paper page.

Unknown The check box whose activation results in the column having an unknown width (explained in the option 'Column width').

The contents of each of the table cells can be filled with an arbitrary text.

Column alignment

The alignment of the text in each column (in the horizontal direction) is possible to be adjusted by choosing one of three alignment methods (left, center, right).



The icon whose activation results in the left alignment of the column text.



The icon whose activation results in the center alignment of the column text.





The icon whose activation results in the right alignment of the column text.

For working with the table rows, there are the command boxes in the '**Table rows**' group:

 **Add** Inserting a new row at the end of the table. The contents of the new column will be copied from the previously active row.

 **Delete** Deleting the active row.

 **Up** Moving the active row upwards.

 **Down** Moving the active row downwards.

No. of rows in the header

This edit box serves for assigning the row number from the top of the table, which will be defined as the header. The rows having the status of header are marked in a special manner. The reason for implementing the header is the division of the cells whose contents are rarely modified (header) from the rest of the table.

Auxiliary table:

Any previously saved additional table can be selected from the list to represent the current one.

 **Save** The currently displayed table is saved in the database.

 **Delete** Deleting the current table from the database.

Save:

Save complete table

The switch enabling the user to save the whole table (with all the rows and columns), along with the contents of all the cells.

Save header only

The switch enabling the user to save the table (with all the rows and columns), along with the contents of the header cells. The rest of the cells will be saved as empty.

13.3 Printing of the report

The printing mode can be adjusted by entering the parameters in the dialog box, that opens up upon activating the 'Print' command by clicking on the icon .

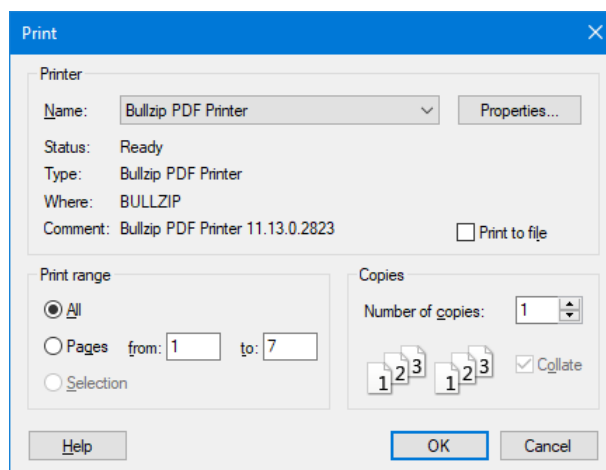

The dialog box for printing of the document - the layout

Printer range

In this part of the dialog box, you will define whether you want to print the whole document or some of its pages.

All The switch whose activation results in demanding the program to print the whole document.

Pages The switch whose activation results in demanding the program to print some part of the document. In the edit box to its right, you can assign the original number of the front and the last page determining the part of the document that is due to be printed.

Number of copies The edit box that allows you to assign the number of copies for the printing.

Print to file The check box whose activation allows you to, instead of directly going to printer, create the directory that can be printed out of the program environment as well.

Clicking the 'OK' command field will result in starting the printing process.

We will remark that, during the printing of the report, the program complies with all the parameters assigned in the 'Text' tab, within the 'Print' dialog box (see Chapter '13.2.4').

13.4 Export into drawing

By activating the '**Export into drawing**' command upon clicking on the icon , you are allowed to place all the tables created in the report on the 'Metal Studio' drawing. Choosing this command will result in program going to the drawing and demanding you to assign the reference point, i.e. the point that will determine the position of the top left corner of the given table in the drawing, for each of the created tables.

Girders and plates - specification:

Upon assigning the reference point, the program places the given table on the drawing, and complies with all the parameters assigned in the 'Text' tab, within the 'AutoCAD drawing' dialog box (see Chapter '13.2.4').

13.5 Export to RTF

The '**Export to RTF**' command allows you to convert complete report to '*.rtf' format, which is readable for almost every Windows text processors, such as 'Word'. By activating this command, using the icon , the following dialog box will open up:

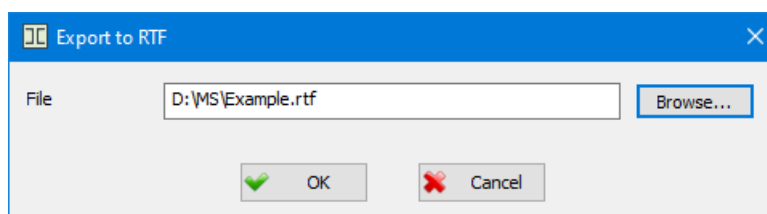

In the edit box '**File**', you assign the place on the drive you want to save the '*.rtf' database you are creating into, as well as the name of the very database. Apart from assigning this data directly into the edit box, you are enabled to open the standard Windows dialog box for saving databases, by activating the button '**Browse...**'.

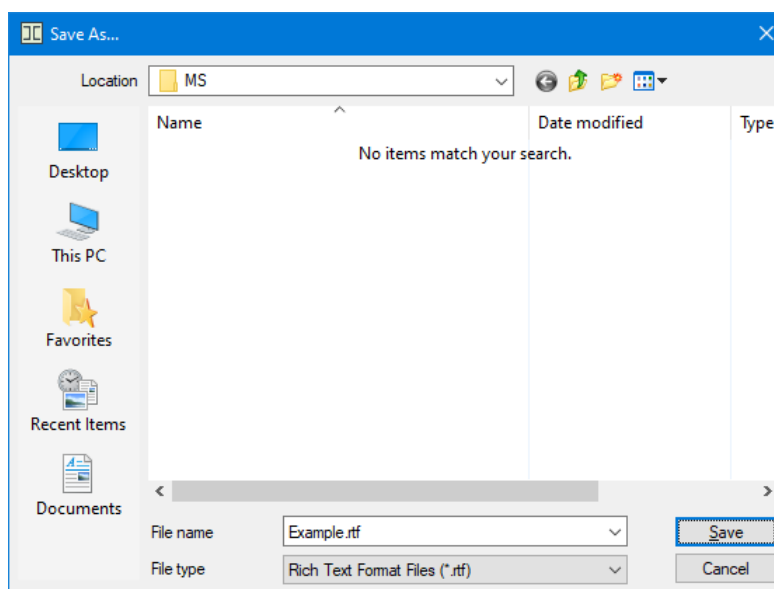

Upon choosing the '**Save**' button, the program will close the current dialog box, and display the data assigned in it in the 'File' edit box of the base dialog box of this command.

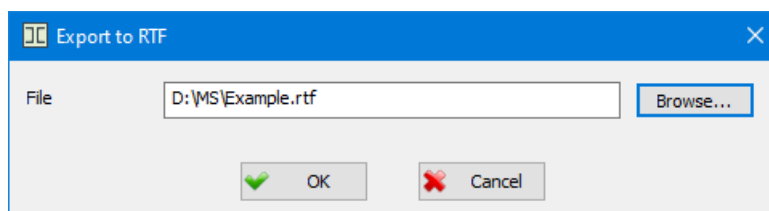

The exporting process begins with choosing the **'OK'** button, and its duration will depend solely upon the report size. You are enabled to completely independently edit the exported report by loading it from 'Word', or some other text processor later on.

As there are no technical possibilities for the header content to be converted into corresponding texts and tables, the header is exported as an image ('meta file'). The disadvantage of this is the inability of updating the possibly placed page counter in the 'Metal studio' header. In such cases, it is recommendable to create the header within 'Word', and to turn the header off from the 'ArmCAD' report. There is another solution, which is not to input the page counter within 'Metal studio' header, but to do it within 'Word'.

13.6 Returning to the drawing window

By activating the **'Back'** command upon clicking on the icon , the returning to the drawing window is performed.

13.7 Overall recapitulation

The **'Overall recapitulation'** command allows you to perform the recapitulation of the shapes, plates and bolts for several selected **'Metal Studio'** directories. It is generally used when you want to know the total weight for the whole construction that has several drawings. Either by selecting the 'Overall recapitulation' command from the **'Metal Studio'** drop-down menu or by clicking on the icon , the following dialog box will open up:

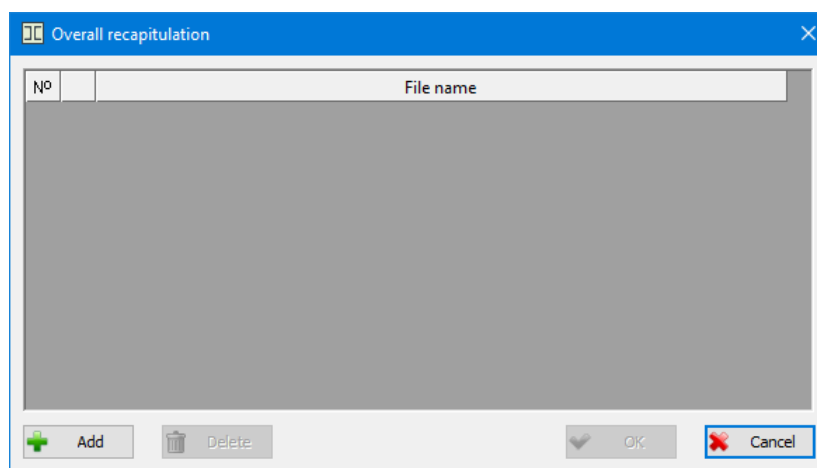

The dialog box for creating the overall recapitulation

Add

Activation of this button results in opening of the dialog box for selection of the 'Metal Studio' directories that you want to create the unique recapitulation for.

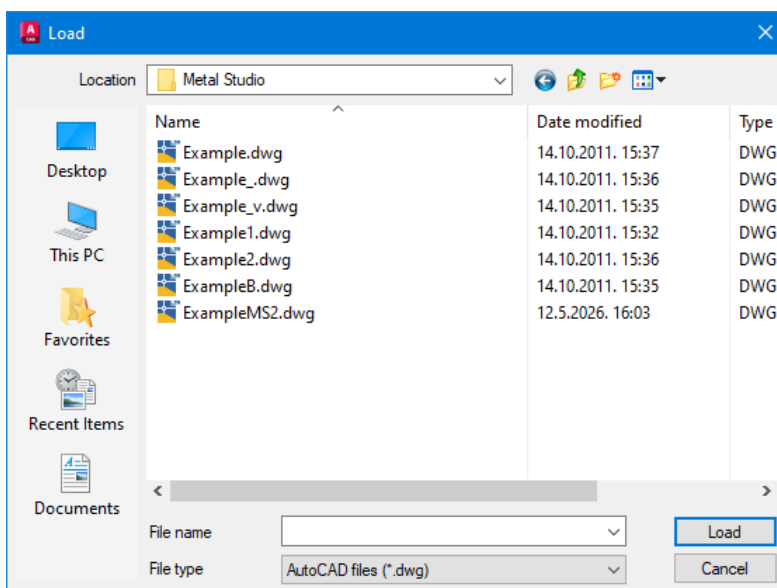

The dialog box for selecting the directories

Within this procedure, it is possible both single and multiple selection of all the desired directories. By selecting the '**Load**' command field, the current dialog box will close, and in the base dialog box of the command, all the selected directories will be displayed.

Delete

The button whose activation will result in deleting the currently selected directory from the list.

No

Column containing the ordinal numbers of the loaded directories.

File name

The list containing the names of the loaded files. Each of the fields in the tag list includes the combo box that opens up by clicking on the arrow to the right. This combo box contains the names of the directories previously used within the 'Overall recapitulation' command, as well as their location on the drive, so that they can be easily selected again, for the purpose of the recapitulation creating. In case some of the directories from the list do not exist anymore (deleted, renamed or moved), they will still be located in the list, but written in gray color and marked as damaged, with the '✖' symbol, and they will be ignored during the recapitulation creating, whereas the '✔' symbol marks the directories that the recapitulation will be created for.

By activating the '**OK**' command field, the program will perform the generation of the overall recapitulation for the directories in the list, and automatically display the report.

The screenshot shows a window titled 'Metal Studio Report - [D:\MS\aprotivo\MS1\Upotstvo\Primeri\Example.dwg]'. The main content is a table with the following data:

Tipovi	Broj	Opis	Opis
POS	POS-01	POS-01	POS-01
POS	POS-02	POS-02	POS-02
POS	POS-03	POS-03	POS-03
POS	POS-04	POS-04	POS-04
POS	POS-05	POS-05	POS-05
POS	POS-06	POS-06	POS-06
POS	POS-07	POS-07	POS-07
POS	POS-08	POS-08	POS-08
POS	POS-09	POS-09	POS-09
POS	POS-10	POS-10	POS-10
POS	POS-11	POS-11	POS-11
POS	POS-12	POS-12	POS-12
POS	POS-13	POS-13	POS-13
POS	POS-14	POS-14	POS-14
POS	POS-15	POS-15	POS-15
POS	POS-16	POS-16	POS-16
POS	POS-17	POS-17	POS-17
POS	POS-18	POS-18	POS-18
POS	POS-19	POS-19	POS-19
POS	POS-20	POS-20	POS-20
POS	POS-21	POS-21	POS-21
POS	POS-22	POS-22	POS-22
POS	POS-23	POS-23	POS-23
POS	POS-24	POS-24	POS-24
POS	POS-25	POS-25	POS-25
POS	POS-26	POS-26	POS-26
POS	POS-27	POS-27	POS-27
POS	POS-28	POS-28	POS-28
POS	POS-29	POS-29	POS-29
POS	POS-30	POS-30	POS-30
POS	POS-31	POS-31	POS-31
POS	POS-32	POS-32	POS-32
POS	POS-33	POS-33	POS-33
POS	POS-34	POS-34	POS-34
POS	POS-35	POS-35	POS-35
POS	POS-36	POS-36	POS-36
POS	POS-37	POS-37	POS-37
POS	POS-38	POS-38	POS-38
POS	POS-39	POS-39	POS-39
POS	POS-40	POS-40	POS-40
POS	POS-41	POS-41	POS-41
POS	POS-42	POS-42	POS-42
POS	POS-43	POS-43	POS-43
POS	POS-44	POS-44	POS-44
POS	POS-45	POS-45	POS-45
POS	POS-46	POS-46	POS-46
POS	POS-47	POS-47	POS-47
POS	POS-48	POS-48	POS-48
POS	POS-49	POS-49	POS-49
POS	POS-50	POS-50	POS-50
POS	POS-51	POS-51	POS-51
POS	POS-52	POS-52	POS-52
POS	POS-53	POS-53	POS-53
POS	POS-54	POS-54	POS-54
POS	POS-55	POS-55	POS-55
POS	POS-56	POS-56	POS-56
POS	POS-57	POS-57	POS-57
POS	POS-58	POS-58	POS-58
POS	POS-59	POS-59	POS-59
POS	POS-60	POS-60	POS-60
POS	POS-61	POS-61	POS-61
POS	POS-62	POS-62	POS-62
POS	POS-63	POS-63	POS-63
POS	POS-64	POS-64	POS-64
POS	POS-65	POS-65	POS-65
POS	POS-66	POS-66	POS-66
POS	POS-67	POS-67	POS-67
POS	POS-68	POS-68	POS-68
POS	POS-69	POS-69	POS-69
POS	POS-70	POS-70	POS-70
POS	POS-71	POS-71	POS-71
POS	POS-72	POS-72	POS-72
POS	POS-73	POS-73	POS-73
POS	POS-74	POS-74	POS-74
POS	POS-75	POS-75	POS-75
POS	POS-76	POS-76	POS-76
POS	POS-77	POS-77	POS-77
POS	POS-78	POS-78	POS-78
POS	POS-79	POS-79	POS-79
POS	POS-80	POS-80	POS-80
POS	POS-81	POS-81	POS-81
POS	POS-82	POS-82	POS-82
POS	POS-83	POS-83	POS-83
POS	POS-84	POS-84	POS-84
POS	POS-85	POS-85	POS-85
POS	POS-86	POS-86	POS-86
POS	POS-87	POS-87	POS-87
POS	POS-88	POS-88	POS-88
POS	POS-89	POS-89	POS-89
POS	POS-90	POS-90	POS-90
POS	POS-91	POS-91	POS-91
POS	POS-92	POS-92	POS-92
POS	POS-93	POS-93	POS-93
POS	POS-94	POS-94	POS-94
POS	POS-95	POS-95	POS-95
POS	POS-96	POS-96	POS-96
POS	POS-97	POS-97	POS-97
POS	POS-98	POS-98	POS-98
POS	POS-99	POS-99	POS-99
POS	POS-100	POS-100	POS-100

13.8 Grouping of assemblies

It often happens that in one drawing, there are multiple assembly positions, and it is only required to create the report for several of them. The **'Grouping of assemblies'** command allows you to group the assembly positions, and afterward, determine the assemblies that will go to the report by choosing one group.

Either by selecting this command from the **'Metal Studio'** drop-down menu or by clicking on the icon , the following dialog box will open up:

The dialog box titled 'Grouping of assemblies' contains a table with the following data:

	Name	Group
1	POS-KR2a	<all assemblies>
2	POS-KR2b	<all assemblies>
3	POS-KR2c	<all assemblies>

Below the table, there is a section for 'Current group of assemblies' with a dropdown menu set to '<all assemblies>' and a 'Delete' button. At the bottom right, there are 'OK' and 'Cancel' buttons.

The dialog box for assembly grouping - the layout

Name The list of all the assembly positions within the drawing.

Group The column where the name of the group the given assembly belongs to is displayed for every assembly position. By default, all the assembly positions are attached to the <all assemblies> group. In order attach the assembly

position to some group, you must assign the name of the desired assembly group in the edit box. Alternatively, for the purpose of attaching the assembly position to some group, you can choose from the combo box. By clicking on the arrow located on the right part of the edit box, a list you can chose some of the provided assembly groups from will open up.

Current group of assemblies

Combo box that allows you to chose the assembly group you want to create the report for.

Delete

The button whose activation will result in deleting of the current assembly group from the drawing, and all the assembly positions that belonged to it are automatically being attached to the default <All assemblies> group. Program will automatically remove from the list the group that has no assemblies attached.

Upon selecting the **'OK'** command field, the program closes the dialog box while accepting all the entered modifications. Upon the next activation of the **'Report'** command (see Chapter '13'), the report will be generated solely for the assemblies belonging to the group that was selected to represent the current one by this command.

14. IMPORT GEOMETRY FROM 'TOWER'

The particular convenience for the users of the '**Metal Studio**' program is the possibility of loading the exported directories, with the geometry of the girders from the 'Radimpex' program for statical calculations - the '**Tower**'. By subsequent modifications of these loaded drawings, it is possible to create the definite executive drawings in the fastest manner.

14.1 Export to 'Metal Studio'

The data transferring between the 'Tower' program and the 'Metal Studio' program is performed using the directories where the data about the girder geometry is saved. Export of the geometry is being executed in the way that the data about the family and type of the shape is saved in the directory, and its contents will be used to compare and copy to appropriate shapes in the 'Metal Studio' program.

Upon activating the command for export of the geometry to the 'Metal Studio' ('**Design ► Steel ► Export to Metal Studio**') in the processing module of the 'Tower' program, the command bar will obtain the following layout:

<0 sel.>Beam selection – Select (All /Window /Polygon /Section /eXtras /Deselect /<End>):

Sub-options '**All**', '**Window**', '**Polygon**', '**Section**' and '**eXtras**' serve to facilitate the selection of the desired beams, while using the sub-option '**Deselect**', the user can exclude incorrectly selected beams from the selection.

While selecting the beams, there are no boundaries, so these do not have to be a part of the same 2D whole (frame, level or inclined view). Upon finished selection, the program opens up the following dialog box:

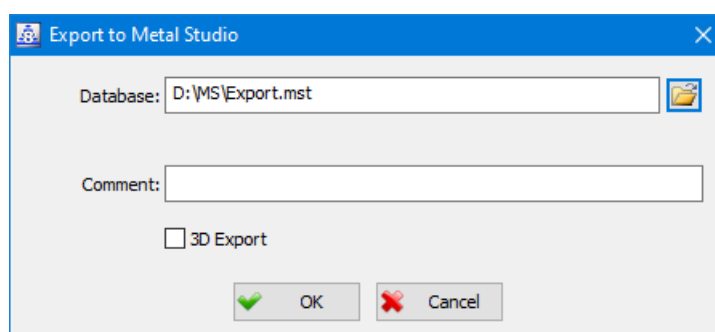

The dialog box for export of the geometry - the layout

Database The edit box for assigning the name of the directory all the data about the girder geometry will be saved to, and by activating the button to the right of this edit box '📁' you are allowed to quickly position yourself to the desired place within the drive of your computer. The directory name can be completely arbitrary, while in the case of the directory, there is the specified default name '*.mst'.

Comment The edit box allowing you to enter an arbitrary comment in the directory, which will help determine its contents, during the next loading to the 'Metal Studio'.

'3D Export' When this check box is turned on, in the 'Metal Studio' program you will have a 3D model, i. e. model with the identical position of all selected beams in space, as it is the case in the 'Tower' program.

In case all the selected beams are not the part of one 2D group (one frame, level or inclined view), and the '3D Export' check box is turned off, the program will export only the selected beams, being the part of the current 2D view.

Choosing the '**OK**' button will terminate this command, so that the geometry of the girders will be exported to the directory under the assigned name. In case you chose the directory with the existing name, the program will issue the appropriate warning:

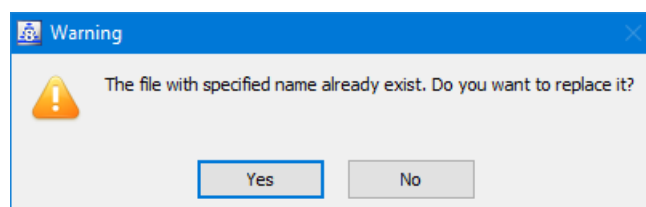

Affirmative response will result in saving the new data in the existing directory, whereas the negative response will result in canceling the saving.

14.2 Import to 'Metal Studio'

Within the 'Metal Studio' program, there is the '**Import geometry from Tower**' command with the purpose of importing the contents of the exported directories from the 'Tower' program to the current drawing. By selecting the command from the '**Metal Studio** ► **Automatization**' drop-down menu, the following dialog box will open up:

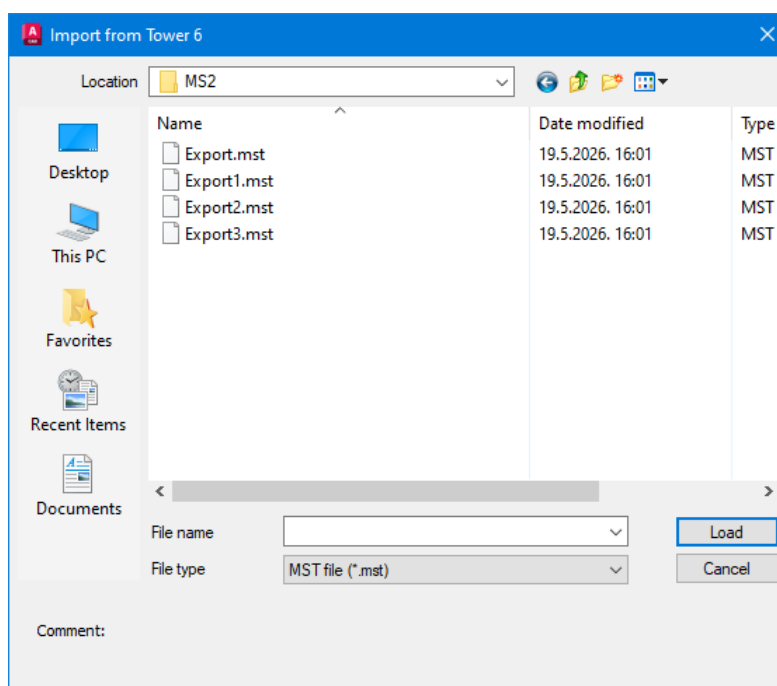

The dialog box for importing the geometry - the layout

It is now necessary that you select one of the previously exported directories and activate the '**Load**' command field (a text comment for the currently selected directory can be written in the

bottom of the dialog box, in case it was attached to it during the export from the 'Tower' program).

Upon closing this dialog box, activating the '**Load**' command field will result in the opening of a new dialog box for copying the shape from the 'Tower' program to the 'Metal Studio' program:

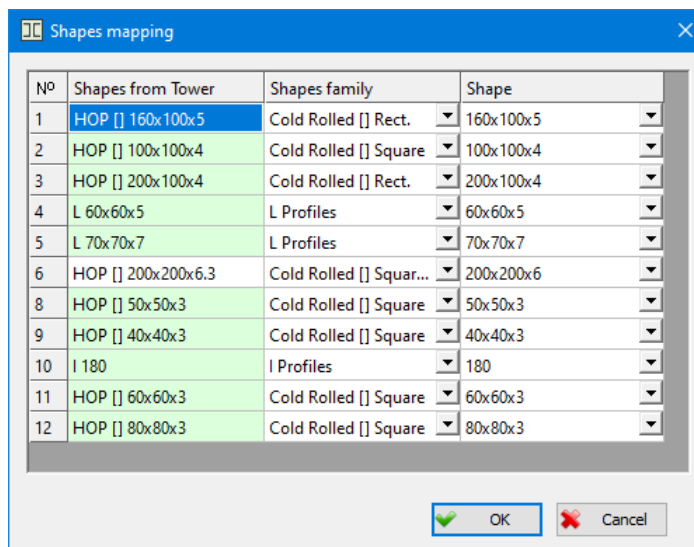

The program will perform an automatic copying of the shapes from the 'Tower' to the corresponding shapes from the shape database in the 'Metal Studio' program.

Nº Beam sets from the 'Tower' program.

Shapes from Tower

The column containing all the shapes saved in the directory imported from the 'Tower' program. The program automatically performs the comparing of the shapes from the 'Tower' with the shapes from the shape database of the 'Metal Studio' program, and, in case it finds the identical shape in the database, this column will be marked with green color. In case such shape does not exist, it will assign the most similar one from the database, and the column will be marked with white color.

Shapes family The combo box with the displayed family the program found in the shape database and assigned to the corresponding shape from the 'Tower'. Naturally, the user is allowed to independently choose some of the provided shape families from the list, corresponding to the given shape from the 'Tower'.

Shape The combo box with the displayed shape symbol that the program found in the shape database and assigned to the corresponding shape from the 'Tower'. Naturally, the user is allowed to independently choose some of the provided shape symbols, corresponding to the given shape from the 'Tower'. As aforesaid, in case there is no corresponding shape in the shape database, the program will assign the most similar shape to the shape from the 'Tower', which will be marked with white color.

By exiting the dialog box upon clicking the '**OK**' button, the program will demand from the command bar that you assign the position of the block, and will draw, in the drag mode, a rectangular area corresponding to its size:

Reference point:

After assigning the reference point, clicking the desired spot in the drawing will define the bottom left part of the block, with the command bar obtaining the new layout, where the user is demanded to enter the angle of the block inclination with respect to the horizontal:

Angle:

After assigning the angle, all the girders will be placed in the drawing.

During the import of the geometry from the 'Tower', the program will always open the new assembly position where all the girder positions are placed to, and whose name, assigned by the program, is 'Export'. In case the assembly position with the same name is already located in the list of the assembly positions, the program will also attach the index '(1)', '(2)', etc to the open assembly position with the name assigned by the program.

15. COMPLEX ELEMENTS

Program 'Metal Studio' enables you to rapidly and easily create the complex elements of the standard connections, that are most common in the practice. Complex elements that can be created within the program are:

- Lateral connection of I-shape beams
- Column beam connection
- Column base
- Beam to beam splice

15.1 Lateral connection of I-shape beams

This command allows you to create the complex element of lateral connection between I-shape beams (I, IPE, IPB, IPB1, IPBv), i.e. connection between one main girder and lateral girders that will be automatically formed, i.e. shortened or lengthened to the main girder. The connection is created via main girder web, using the connection shapes (L-shapes and bended plates of L cross section) and corresponding connection devices (bolt series and welds). Either by selecting the '**Lateral connection of I-shape beams**' command from the '**Metal Studio ► Automatization**' drop-down menu or by clicking on the icon , the user is requested to select the main girder, with the command bar obtaining the following layout:

Selecting main girder [Exit] <Exit>:

Selected girder is marked in green, and afterwards, selecting lateral girders is expected:

Selecting lateral girder [Exit] <Exit>:

Upon selecting first lateral girder, which is now also marked in green, the command bar obtains the new layout:

Selecting second lateral girder [Exit] <Exit>:

Now, the user is requested to select second lateral girder, afterwards the dialog box for defining the connection opens up. In case the user wants to create the connection between the main girder and only one lateral girder, it is necessary to chose the 'Exit' sub-option from the command bar.

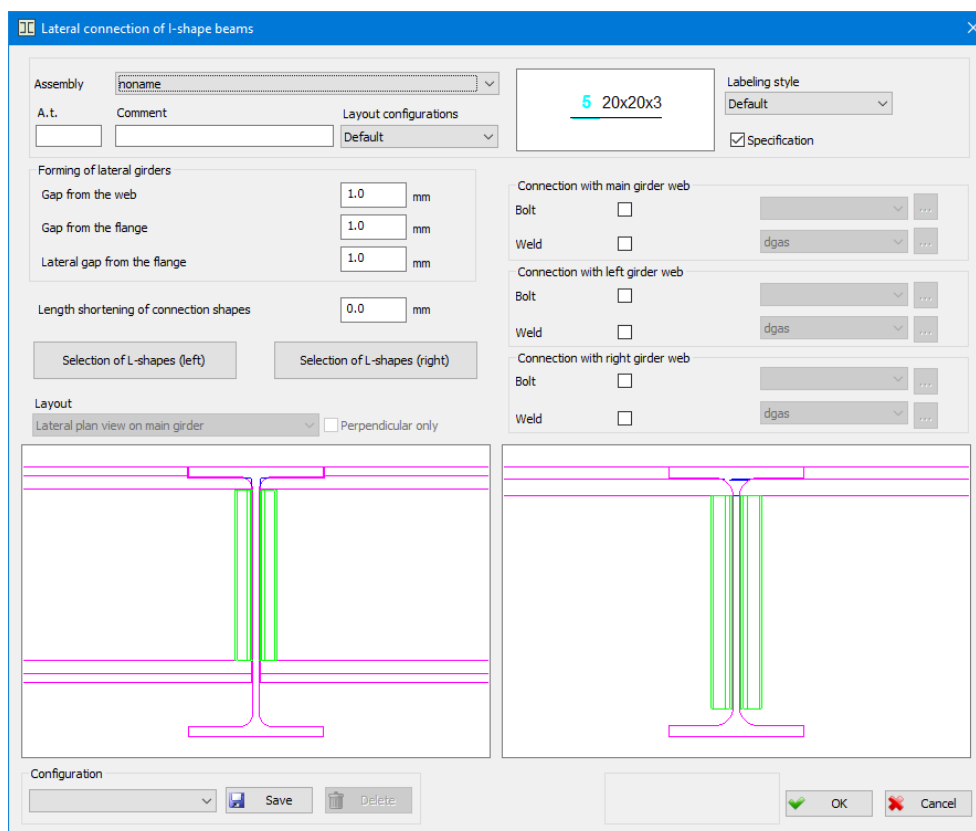

The dialog box for defining the lateral connection of I-shape beams- the layout

Longitudinal plan view on lateral girders so that there are lateral girders and connection shapes in plan view, as well as the main girder in cross section, are shown in the left drawing. Longitudinal plan view on main girder so that it is shown in plan view, as well as the connection shapes, while the lateral girders are in cross section, are shown in the right drawing. All modification performed in the dialog box are automatically displayed in these drawings, which enables the user to have comprehensive and clear insight and easily work within the dialog box.

Layout From the combo box, you can chose one of the available girder plan views.

Perpendicular only

Only perpendicular girders will be shown in the drawings.

Data referring to all the elements, i.e. positions formed during the creation of complex element are show in the upper part of the dialog box.

Assembly The combo box for selecting some of previously defined assembly positions.

A.t. The edit box for entering the **additional tag** of positions displayed in the label.

Comment The exit box for assigning the arbitrary comment of positions displayed in the label.

Labeling style From the combo box, you can chose one of previously defined label style configurations. "Preview" located on the left from this box, displays the label layout, corresponding for the chosen style.

Specification The check box for determining whether the position is going into specification or not.

Layout configuration

The combo box for choosing one of previously defined entity layout configurations.

Forming of lateral girders

In this part of the dialog box, forming of lateral girder ends located near the web of main girder is defined.

Gap from the web

The edit box for assigning the distance of lateral girders from main girder web.

Gap from the flange

The edit box for assigning the vertical distance of lateral girders from main girder flange.

Lateral gap from the flange

The edit box for assigning the lateral, i.e. horizontal distance of lateral girders from main girder flange.

Length shortening of connection shapes

The program automatically calculates the length of connection shapes depending on the chosen lateral girders, so that it corresponds the web height of lateral girder (excluding the bended parts). By entering the corresponding value in this edit box, the user is enabled to perform the length shortening of connection shapes, via shortening both ends of connection shape girders for assigned value.

Selection of L-shapes (left)

By activating this button, a dialog box for defining the connection shapes for left lateral girder opens up.

Selection of L-shapes (right)

By activating this button, a dialog box for defining the connection shapes for right lateral girder opens up.

Selection of L-shapes

This button appears in the dialog box in case the connection of main and only one lateral girder is defined. By activating this button, a dialog box for defining the connection shapes for that lateral girder opens up.

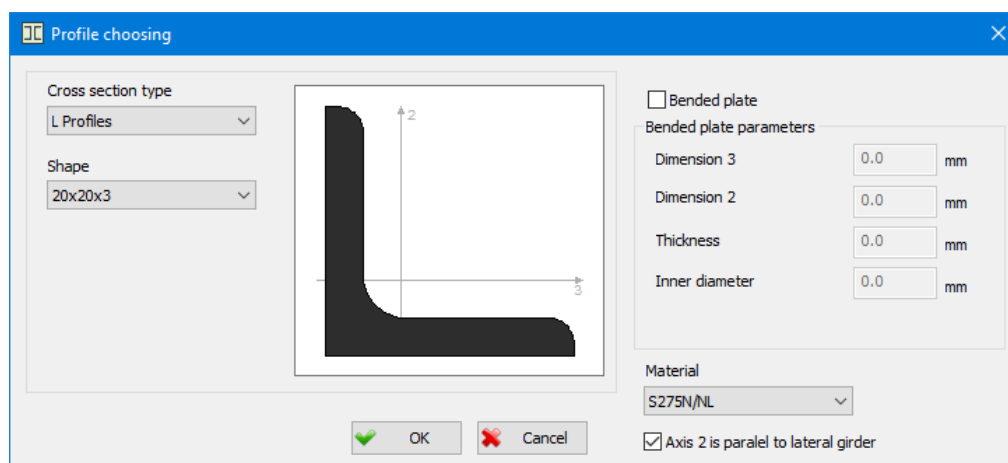

The dialog box for defining and choosing the connection shapes- the layout

The program enables you to define two types of connection shapes: L-shapes, which are defined by choosing one of the available shapes from the profile database and bended plate (Chapter 4.5) whose cross section has the form of L cross section, and whose dimensions are assigned by the user.

Cross section type

The combo box for choosing the L-shape type. All L-shape types from currently active profile database are located in the box (L-shapes, HOP L, ...). By choosing one of available L-shape types from the box, its cross section will show in the drawing. It is necessary to note that this box is active solely in case the check box 'Bended plate' is off.

Shape

The combo box where all the L-shapes of particular type for which there is data presented in database are located.

Bended plate

When this check box is on, it enables defining the bended plate geometry, while the 'Cross section type' and 'Shape' boxes become inactive.

Bended plate parameters

Part of the dialog box for defining the L cross section bended plate geometry, by entering its dimensions within the edit boxes. The drawing shows the bended plate cross section that corresponds the assigned data.

Dimension 3

The edit box for assigning the bended plate cross section dimension, that is parallel with axis 3 in the drawing in the dialog box.

Dimension 2

The edit box for assigning the bended plate cross section dimension, that is parallel with axis 2 in the drawing in the dialog box.

Thickness

The edit box for assigning the bended plate thickness.

Inner diameter

The edit box for assigning the inner diameter of the curved part of bended plate.

Material

The combo box for selecting one of previously defined steel categories.

Axis 2 is paralel to lateral girder

The state of this check box determines which side of connection shape is located near the lateral girder web. In case the check box is on, side parallel with axis 2 will be located beside the lateral girder web. In case the check box is off, side parallel with axis 3 will be located beside the lateral girder web.

By pressing the 'OK' button and exiting this dialog box, all the modifications in the dialog box will be accepted, and the user is returned to the main dialog box for defining the lateral connection of I-shape beams, where all these modifications will be shown in the drawings.

Connection with main girder web:

The part of the dialog box for defining whether the connection between main girder web and connection shapes is performed using the bolt series or the welds.

Bolt

By turning this check box on, a bolt series is placed where the main girder web and connection shapes are connected, and the list located on the right from this check box becomes active and any previously saved configuration can be selected from this list to represent the current one.



Button upon activating which the dialog box for assigning all the parameters necessary for creating the bolt series opens up.

Weld

By turning this check box on, welds are placed where the main girder web and connection shapes are connected, and the list located on the right from this check box becomes active and any previously saved configuration can be selected from this list to represent the current one.



Button upon activating which the dialog box for assigning all the parameters necessary for defining the weld plan view opens up.

Connection with left girder web:

The part of the dialog box for defining whether the connection between left lateral girder web and connection shapes is performed using the bolt series or the welds

Bolt

By turning this check box on, a bolt series is placed where the left lateral girder web and connection shapes are connected, and the list located on the right from this check box becomes active and any previously saved configuration can be selected from this list to represent the current one.



Button upon activating which the dialog box for assigning all the parameters necessary for creating the bolt series opens up.

Weld

By turning this check box on, welds are placed where the left lateral girder web and connection shapes are connected, and the list located on the right from this check box becomes active and any previously saved configuration can be selected from this list to represent the current one.



Button upon activating which the dialog box for assigning all the parameters necessary for defining the weld plan view opens up.

Connection with right girder web:

The part of the dialog box for defining whether the connection between right lateral girder web and connection shapes is performed using the bolt series or the welds. Working within this dialog box is the same as working within the 'Connection with left girder web' part of the dialog box, and therefore will not be explained again.

Connection with lateral girder web:

This part appears in the dialog box in case the connection of main and only one lateral girder is created, and has the purpose of defining whether this connection is performed using the bolt series or the welds. Working within this dialog box is the same as working within the 'Connection with left girder web' part of the dialog box, and therefore will not be explained again.

Configuration:

Any previously saved configuration can be selected from this list to represent the current one.



Save

The configuration with the current state of parameters in the dialog box is saved in the database



Delete

Deleting the current configuration from the database.

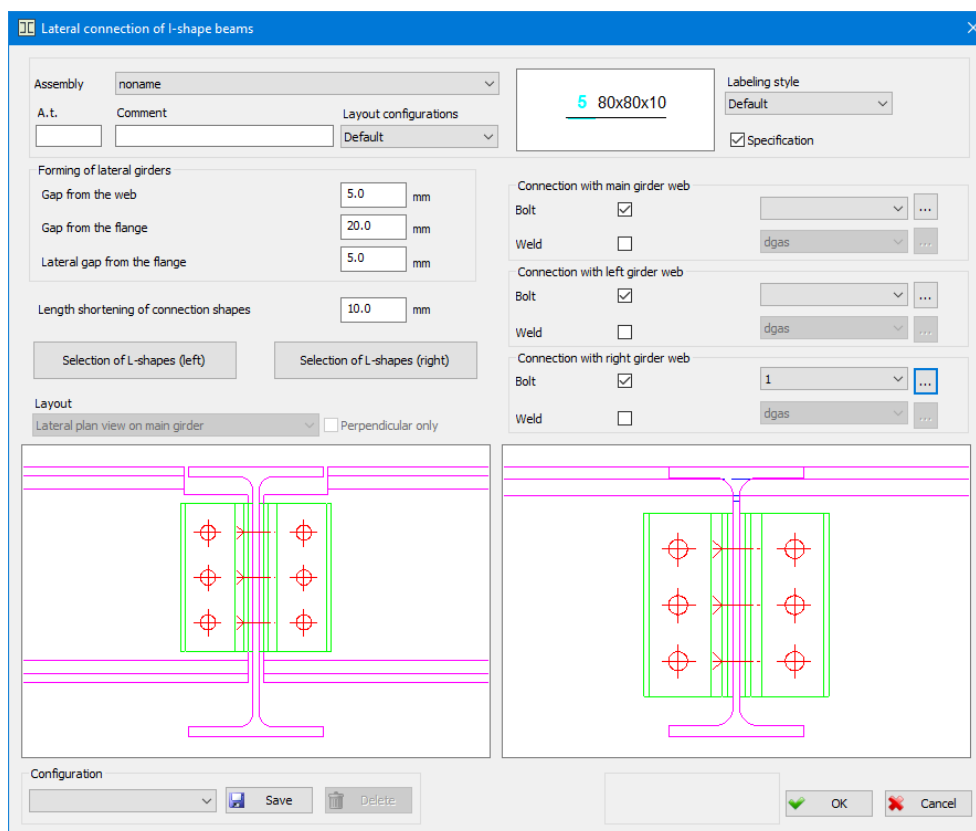

By pressing the 'OK' button and exiting this dialog box, the connection between main girder and lateral girders will be created in the drawing, based on the data assigned in the dialog box.

15.2 Column beam connection

This command allows you to create the complex element for connection between column and beam. The connection is created using flat and bended plates, with or without endplate and corresponding connection devices. Either by selecting the '**Column beam connection**' command from the '**Metal Studio ► Automatization**' drop-down menu or by clicking on the icon , the user is requested to select the column, with the command bar obtaining the following layout:

Selecting column [Exit] <Exit>:

Selected girder is marked in green, and afterwards, selecting girder representing the beam, whose end will automatically be formed, i.e. shortened or lengthened to the column is expected:

Selecting beam [Exit] <Exit>:

Upon selecting first beam, the dialog box for creating the connection between beam and column opens up:

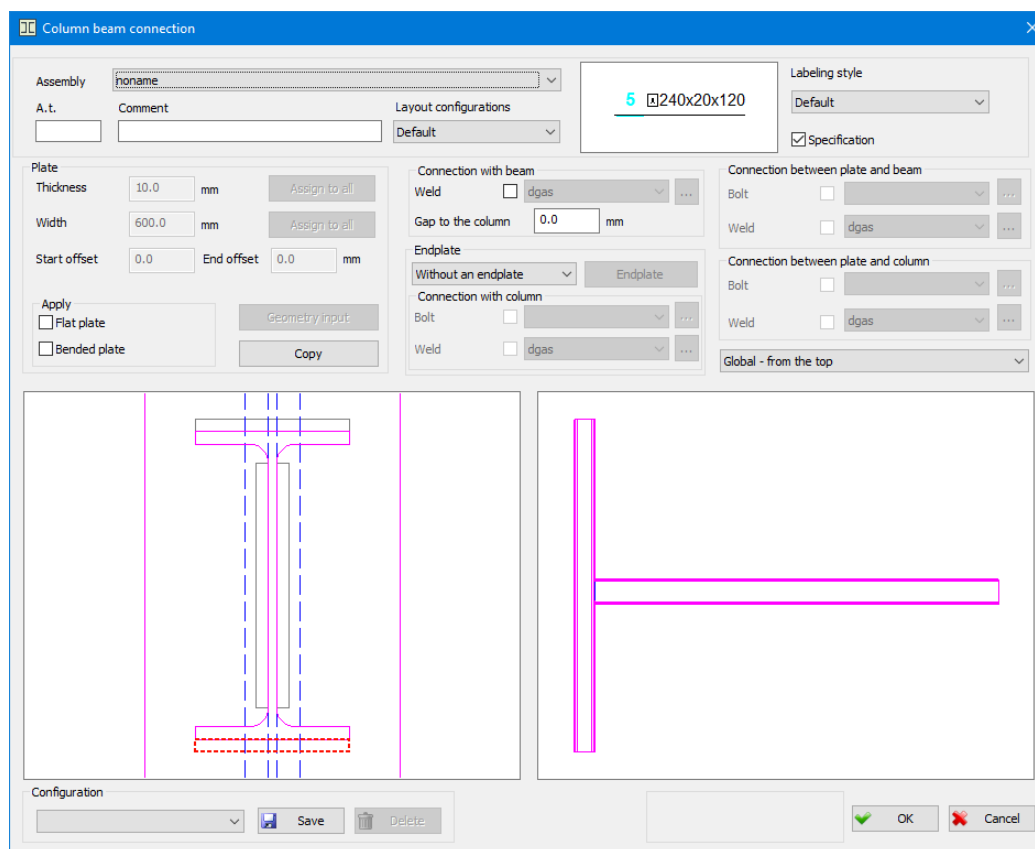

The dialog box for defining and choosing the connection between beam and column - the layout

Lateral plan view of beam and initial plate positions are shown in the left drawing, while showing of the right drawing depends on the view chosen from the list above this drawing. All modification performed in the dialog box are automatically displayed in these drawings, which enables the user to have comprehensive and clear insight and easily work within the dialog box.

Data referring to all the elements, i.e. positions formed during the creation of complex element are show in the upper part of the dialog box.

Assembly The combo box for selecting some of previously defined assembly positions.

A.t The edit box for entering the **additional tag** of positions displayed in the label.

Comment The edit box for assigning the arbitrary comment of positions displayed in the label.

Labeling style From the combo box, you can chose one of previously defined label style configurations. "Preview" located on the left from this box, displays the label layout, corresponding for the chosen style.

Specification The check box for determining whether the position is going into specification or not.

Layout configurations

The combo box for choosing one of previously defined entity layout configurations.

- Plate** The part of the dialog box for defining the geometric characteristics of the plates that will be the part of creating the connection between beam and column. Depending on the needs, user can chose flat or bended plates of L cross section. In the left drawing, in the dialog box, position of all the plates located in this assembly is shown in gray. Hovering the mouse over them results in them changing the color, and when mouse pointer is placed above the plate, it is shown in yellow, and may be selected by left-clicking it. Currently active plate is shown in red. Right-clicking of the mouse over currently selected plate results in opening the drop-down menu with options for entering its geometry (**'Flat plate - geometry input'** and **'Bended plate - geometry input'**), copying of the plate geometry (**'Copy'**), as well as option for its placement into the connection (**'Toggle inclusion'**).
- Apply** Part of the dialog box with two check boxes for defining whether the flat or bended plate is being placed.
- Flat plate** The check box upon activating which the currently selected plate is placed in the connection as flat plate, and it is showed in green now.
- Thickness** The edit box that becomes active after turning on the 'Flat plate' check box, and it is where the thickness of currently selected flat plate is assigned.
- Assign to all** By activating the button located on the left from the 'Thickness' edit box, you assign the entered thickness value to all the plates.
- Width** The edit box that becomes active after turning on the 'Flat plate' check box, and it is where the width of currently selected flat plate is assigned.
- Assign to all** By activating the button located on the left from the 'Width' edit box, you assign the entered width value to all the plates.
- Geometry input** The program automatically calculates the length of flat plate, depending on the chosen shape, so that the plate placed near the beam web has the length identical to the web height, while the length of the plate near the flange is identical with the flange width. By activating this button, a dialog box for plate forming, where the user can independently alter all the data connected to the plate geometry, as well as perform the plate forming, opens up.

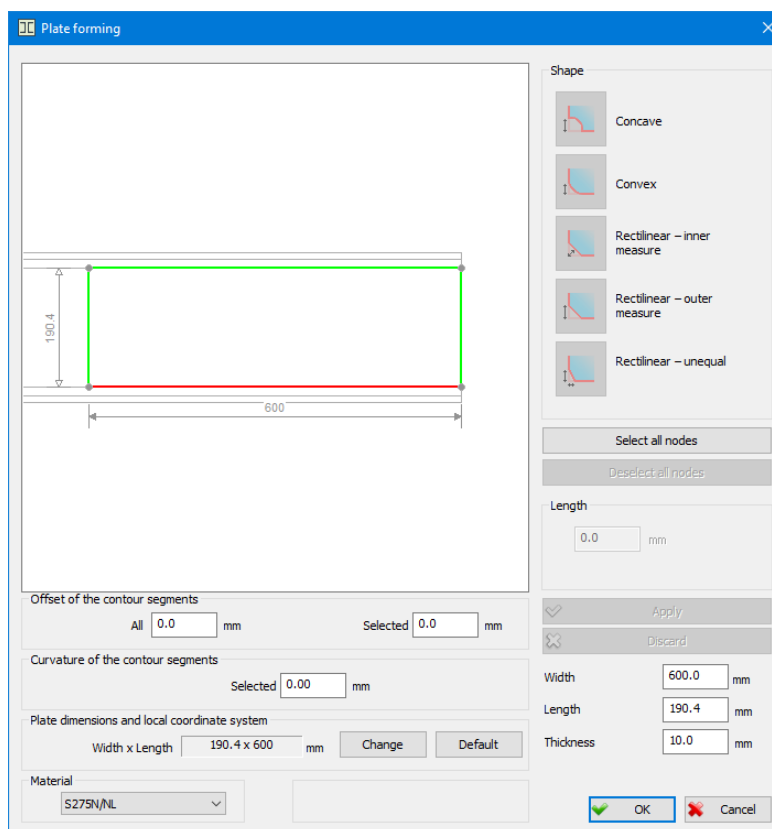

The dialog box for inserting the geometry and plate forming

- Width** The edit box for assigning the flat plate width.
- Length** The edit box for assigning the flat plate length.
- Thickness** The edit box for assigning the flat plate thickness.
- Material** The combo box for selecting one of previously defined steel categories.

Working within this dialog box is explained in detail in Chapter 4.3, and therefore will not be explained again.

By pressing the **'OK'** button and exiting this dialog box, all the modifications in the dialog box will be accepted, and the user is returned to the main dialog box for defining the connection between beam and column, where all these modifications will be shown in the drawings.

- Bended plate** The check box upon activating which the currently selected plate is placed in the connection as bended plate of L cross section, and it is showed in green now.
- Start offset** The edit box that becomes active after turning on the 'Bended plate' check box. The program automatically calculates the length of bended plate, depending on the chosen shape, so that the plate placed near the beam web has the length identical to the web height, while the length of the plate near the flange is identical to the flange width. By entering the corresponding value in this edit box, the user is enabled to perform the bend plate length shortening, by offsetting the frontal plate end for the assigned value.
- End offset** The edit box that becomes active after turning on the 'Bended plate' check box. The program automatically calculates the length of bended plate, depending on the chosen shape, so that the plate placed near the beam web has the length

identical to the web height, while the length of the plate near the flange is identical to the flange width. By entering the corresponding value in this edit box, the user is enabled to perform the bend plate length shortening, by offsetting the frontal back plate end for the assigned value.

Geometry input

The button upon activating which the dialog box for defining the bended plate by assigning its dimensions or by choosing one of the available L-shapes from the shape database opens up.

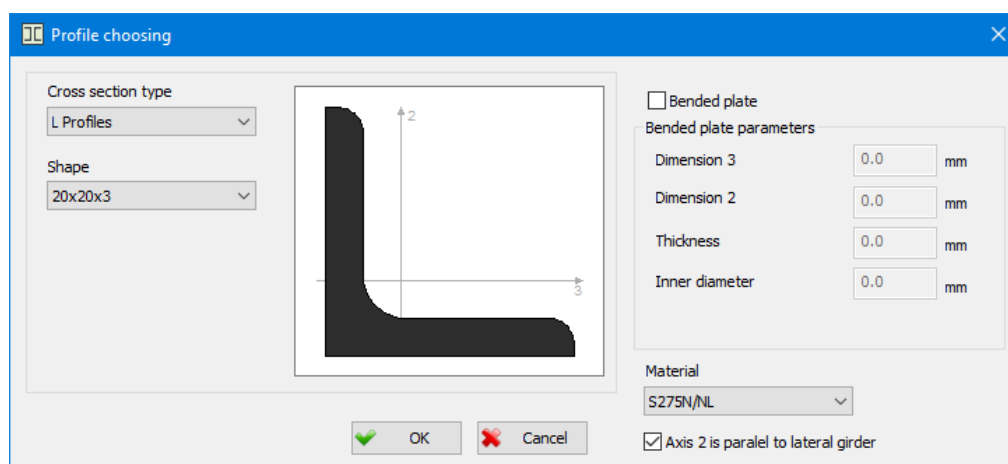

Working within this dialog box is explained in detail in Chapter 15.1, and therefore will not be explained again.

By pressing the 'OK' button and exiting this dialog box, all the modifications in the dialog box will be accepted, and the program is returned to the main dialog box for defining the connection between beam and column, where all these modifications will be shown in the drawings.

Copy

Considering the fact that within the connection between beam and column several identical plates appear, the user is enabled to copy the defined plate geometry onto other plates. The plate whose data you want to assign to other plates must be selected in the left drawing in the dialog box, and afterwards choose the 'Copy' button, while its data will be copied, and the copied plate will be shown in white while the command is active. After that, it is necessary to place the mouse pointer above the plate you want to assign the data of copied plate to, and when it turns yellow, left-click it. The program will assign all the data of copied plate to the selected plate. The copying ends by left-clicking the empty space in the drawing.

Connection with beam

The part of the dialog box in which it is possible to place the welds where the beam is connected to the column. The beam can be welded to the column directly or via endplate.

Weld

By turning this check box on, the welds are placed where the beam is connected to the column. Of course, this check box is active only in case there is no clearance between beam and column, because only in that case it is possible to place the welds. The list located on the right of this check box becomes active, and any previously saved configuration can be selected from this list to represent the current one.



Button upon activating which the dialog box for assigning all the parameters necessary for defining the weld plan view opens up.

Gap to the column

The edit box for entering the value the beam will be offset from the column for, so that the entered value will represent the distance-clearance between beam and column.

Endplate

The button that is active solely in case the **'Put in'** is chosen from the combo box located on the left of it. By activating the button, the dialog box for defining the endplate opens up.

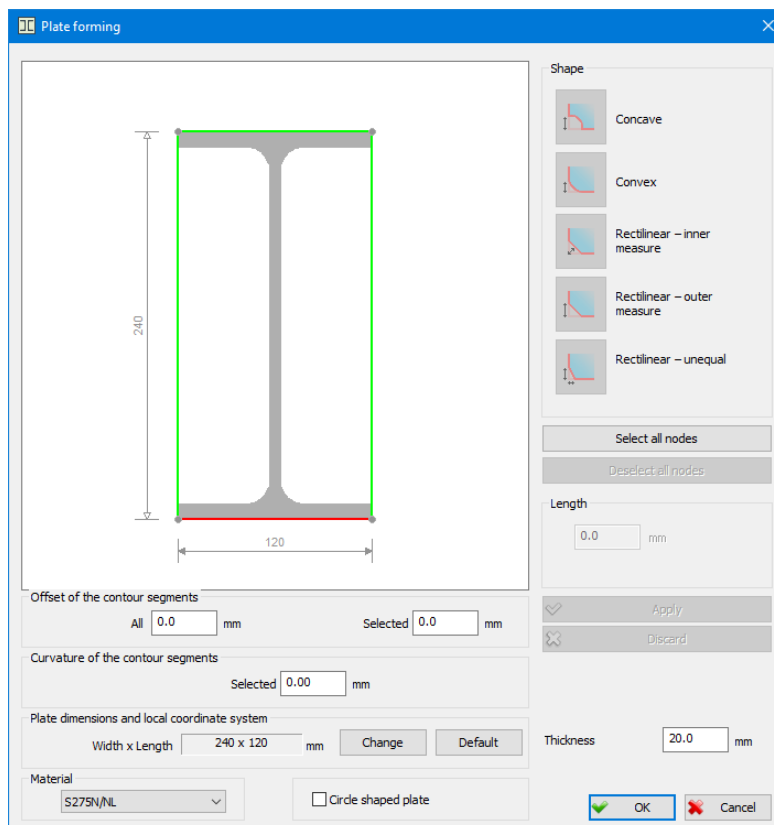

The dialog box for defining the endplate

Thickness The edit box for assigning the endplate thickness.

Circle shaped plate

Check box upon activating which the endplate obtains the circular shape.

Material The combo box for selecting one of previously defined steel categories.

Working within this dialog box is explained in detail in Chapter 4.3, and therefore will not be explained again.

By pressing the **'OK'** button and exiting this dialog box, all the data defined in the dialog box will be assigned to the endplate, and the user is returned to the main dialog box for defining the connection between beam and column.

Connection with column

The part of the dialog box for defining whether the connection of endplate and column is created using the bolt series or the welds.

Bolt

By turning this check box on, a bolt series is placed where the endplate and column are connected, and the list located on the right from this check box becomes active and any previously saved configuration can be selected from this list to represent the current one.



Button upon activating which the dialog box for assigning all the parameters necessary for creating the bolt series opens up.

Weld

By turning this check box on, welds are placed where the endplate and column are connected. The list located on the right from this check box becomes active and any previously saved configuration can be selected from this list to represent the current one.



Button upon activating which the dialog box for assigning all the parameters necessary for defining the weld plan view opens up.

Connection between plate and beam

The part of the dialog box where it is particularly defined, for every plate previously placed in the connection and marked in green, how its connection with beam is performed, i.e. are the bolt series or weld placed where the connection is. It is necessary to firstly left-click and select the placed plate from the left drawing in the dialog box. The selected plate is marked in red. In case the plate is not connected, this part of the dialog box will be inactive. In case the selected plate is connected, this part of the dialog box becomes active and all the modifications in it will refer solely to the connection between selected plate and beam. The user is now enabled to place the connection devices where selected plate and beam are connected.

Bolt

By turning this check box on, a bolt series is placed where the selected plate (plate selected from the left drawing in the dialog box) and beam are connected, and the list located on the right from this check box becomes active and any previously saved configuration can be selected from this list to represent the current one.



Button upon activating which the dialog box for assigning all the parameters necessary for creating the bolt series opens up.

Weld

By turning this check box on, welds are placed where the selected plate (plate selected from the left drawing in the dialog box) and beam are connected. The list located on the right from this check box becomes active and any previously saved configuration can be selected from this list to represent the current one.



Button upon activating which the dialog box for assigning all the parameters necessary for defining the weld plan view opens up.

Connection between plate and column

The part of the dialog box where it is particularly defined, for every plate previously placed in the connection and marked in green, how its connection with column is performed, i.e. are the bolt series or weld placed where the connection is. It is necessary to firstly left-click and select the placed plate from the left drawing in the dialog box. The selected plate is marked in red. In case the plate is not connected, this part of the dialog box will be inactive. In case the selected plate is connected, this part of the dialog box becomes active and all the modifications in it will refer solely to the connection between selected plate and column. The user is now enabled to place the connection devices where selected plate and column are connected.

Bolt

By turning this check box on, a bolt series is placed where the selected plate (plate selected from the left drawing in the dialog box) and column are connected, and the list located on the right from this check box becomes active and any previously saved configuration can be selected from this list to represent the current one.



Button upon activating which the dialog box for assigning all the parameters necessary for creating the bolt series opens up.

Weld

By turning this check box on, welds are placed where the selected plate (plate selected from the left drawing in the dialog box) and column are connected. The list located on the right from this check box becomes active and any previously saved configuration can be selected from this list to represent the current one.



Button upon activating which the dialog box for assigning all the parameters necessary for defining the weld plan view opens up.

Configuration:

Any previously saved configuration can be selected from this list to represent the current one.

Save

The configuration with the current state of parameters in the dialog box is saved in the database.

Delete

Deleting the current configuration from the database.

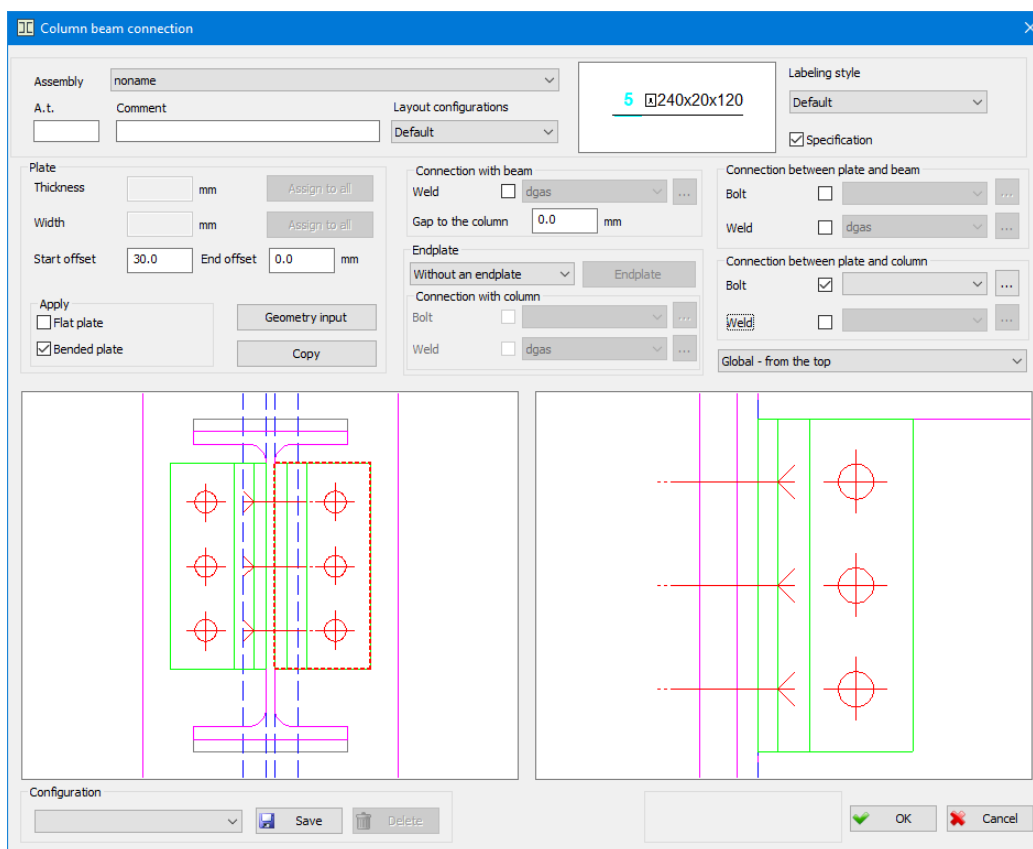

By pressing the **'OK'** button and exiting this dialog box, the connection between beam and column will be created, base on the data assigned in the dialog box.

15.3 Column base

This command allows you to create the complex element of the column bases. Either by selecting the **'Column base'** command from the **'Metal Studio ► Automatization'** drop - down menu or by clicking on the icon , the user is requested to select the girder, with the command bar obtaining the following layout:

Selecting girder - column [Exit] <Exit>:

Upon selecting girder, the dialog box for creating the complex element opens up:

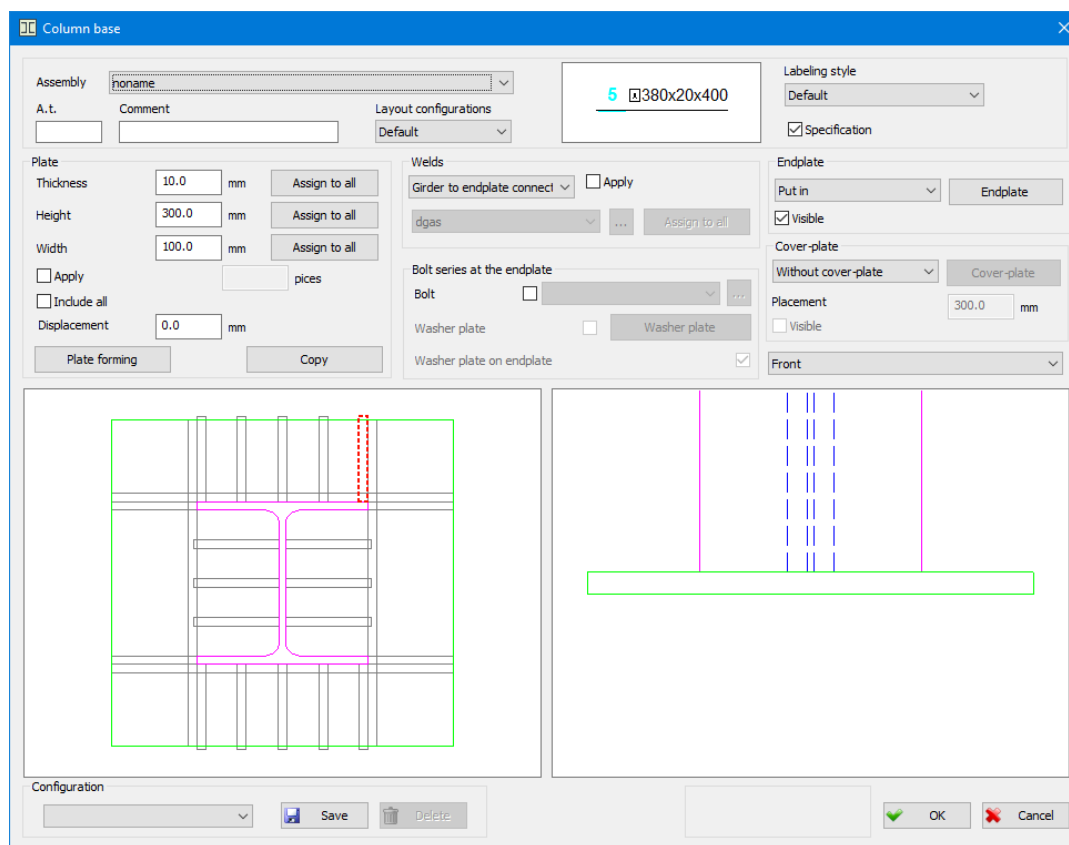

The dialog box for defining the column base– the layout

Lateral plan view of column and initial plate positions are shown in the left drawing, while showing of the right drawing depends on the view chosen from the list above this drawing. All modification performed in the dialog box are automatically displayed in these drawings, which enables the user to have comprehensive and clear insight and easily work within the dialog box.

Data referring to all the elements, i.e. positions formed during the creation of complex element are show in the upper part of the dialog box.

Assembly The combo box for selecting some of previously defined assembly positions.

A.t. The edit box for entering the **additional tag** of positions displayed in the label.

Comment The edit box for assigning the arbitrary comment of positions displayed in the label.

Labeling style From the combo box, you can chose one of previously defined label style configurations. 'Preview' located on the left from this box, displays the label layout, corresponding for the chosen style.

Specification The check box for determining whether the position is going into specification or not.

Layout configuration

The combo box for choosing one of previously defined entity layout configurations.

Plate: The part of the dialog box for defining the geometric characteristics of the lateral plates that will be the part of creating the complex element. In the left drawing, in the dialog box, position of all the plates located in this assembly is

shown in gray. Initial position of the lateral plates depends on the selected column shape. The plates are grouped into assemblies, according to their position around the cross section, and all the plates from the same assembly, belong to the same position. Hovering the mouse over them results in them changing the color, and when mouse pointer is placed above the plate, it is shown in yellow, while the plates belonging to the same assembly are shown in blue. The plate shown in yellow, may be selected by left-clicking it. Currently active plate is shown in red, and the right-clicking it with the mouse results in opening the drop-down menu with options for entering its geometry (**'Plate forming'**), copying of the plate geometry (**'Copy'**), as well as option for its placement into the complex element of all the plates belonging to the same assembly (**'Include whole group'** and **'Exclude whole group'**).

- Apply** The check box upon turning which the currently selected plate is set into the complex element and showed in green. The edit box located on the right from this check box has the purpose of assigning the **number of pieces** of plates to be located within the assembly the selected plate belongs to.
- Include all** The check box upon turning which all the plates from the same assembly are set into the complex element and showed in green.
- Displacement** The adjacent plates located in the corners of shapes can be moved in a translational manner, in relation to their initial position, so in case of their selection, this edit box becomes active. By assigning the value into the edit box, the moving of currently selected adjacent plate will be performed, along with the conservation of the mutual distances between other plates.
- Primary direction** The program enables the placement of the plates surrounding the shape cross section, and in case they are selected, this check box becomes active. Considering their geometry and the fact that these plates may be placed into two directions, by turning on the check box, currently selected plate has the primary direction. Since the plates are not able to pass one through another, the plate with the primary direction is single-sectioned, while the plate with some other direction is divided in two positions, on the place of other plate passing.
- Thickness** The edit box for assigning the currently selected plate thickness. Of course, identical value is automatically assigned to all the plates belonging to the assembly the selected plate belongs to.
- Assign to all** By activating the button located on the left from the 'Thickness' edit box, you assign the entered thickness value to all the plates.
- Height** The edit box for assigning the currently selected plate height. Of course, identical value is automatically assigned to all the plates belonging to the assembly the selected plate belongs to.
- Assign to all** By activating the button located on the left from the 'Height' edit box, you assign the entered height value to all the plates.
- Width** The edit box for assigning the currently selected plate width. Of course, identical value is automatically assigned to all the plates belonging to the assembly the selected plate belongs to.

Assign to all By activating the button located on the left from the 'Width' edit box, you assign the entered width value to all the plates.

Plate forming The button upon activating which a dialog box for forming plates where the user can independently alter all the data in relation to the plate geometry, as well to form the plate, will open up.

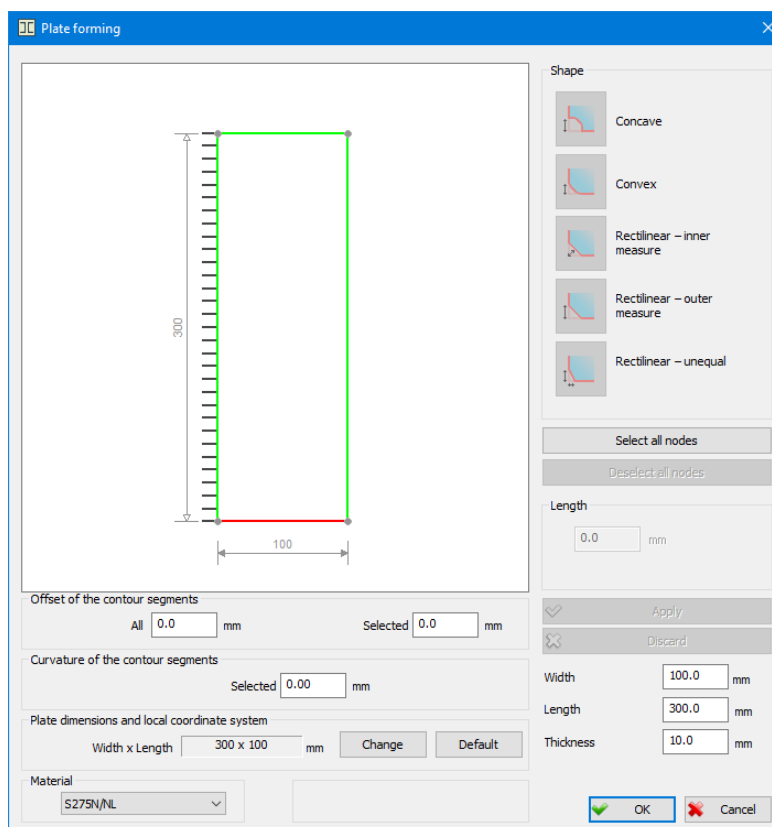

The dialog box for entering the geometry and plate forming

Considering the fact the plates with the purpose of column fitting are placed in this complex element, the angle forming of these plates are performed, so, in the drawing, for the purpose of easier work in this dialog box, the weld in plan view is symbolically shown, on the position of connection with column. Therefore, the user is enabled to have an insight in the plate position in the complex element, and a clear image of which angles he wants to form.

Width The edit box for assigning the plate width.

Length The edit box for assigning the plate length.

Thickness The edit box for assigning the plate thickness.

Material The combo box for selecting one of previously defined steel categories.

Working within this dialog box is explained in detail in Chapter 4.3, and therefore will not be explained again.

By pressing the '**OK**' button and exiting this dialog box, all the modifications in the dialog box will be accepted, and the user is returned to the main dialog box for defining the complex element, where all these modifications will be shown in the drawings.

Copy Considering the fact that this complex element is generally created from a larger number of identical plates, the user is enabled to copy the defined plate geometry onto other plates. The plate whose data you want to assign to other plates must be selected in the left drawing in the dialog box, and afterwards choose the 'Copy' button, while its data will be copied, and the copied plate, i.e. all the plates from corresponding assembly, will be shown in white while the command is active. After that, it is necessary to place the mouse pointer above the plate you want to assign the data of copied plate to, and when it turns yellow, left-click it. The program will assign all the data of copied plate to the selected plate. The copying ends by left-clicking the empty space in the drawing.

Welds: The part of the dialog box for defining the connection places the welds are positioned in.

Apply By turning on this check box, the welds will be placed on all the connection places the user chooses. It is necessary to firstly chose one of the available connections from the combo box on the left from this check box, and afterwards, activate the check box 'Apply':

Girder to endplate connection – welds will be placed where girder connects with endplate.

Girder to side-plates connection – welds will be placed where girder connects with lateral plates.

Endplate to side-plates connection – welds will be placed where endplate connects with lateral plates.

Cover-plate to side-plates connection – welds will be placed where cover-plate connects with lateral plates.

The list located below the list with the available connection types, becomes active by turning the 'Apply' check box on, and any previously saved configuration can be selected from this list to represent the current one.



Button upon activating which the dialog box for assigning all the parameters necessary for defining the weld plan view opens up.

Assign to all By activating this button, the placed weld configuration, i.e. all the parameters set in the dialog for assigning the welds in plan view, is assigned to all the connections from the list. This way, the defined weld for one connection can be easily assigned to all the other connections

Bolt series et the endplate

The part of the dialog box for degining the bolt series placed onto the endplate.

Bolt By turning this check box on, a bolt series is placed onto the endplate, and the list located on the right from this check box becomes active and any previously saved configuration can be selected from this list to represent the current one.



Button upon activating which the dialog box for assigning all the parameters necessary for defining the bolt series opens up.

Washer plate By turning the check box, located on the left from this button, on, the washer plates are placed near the bolts of endplate. Activating the button results in entering the dialog box for defining the washer plate characteristics.

Washer plate on endplate

By turning this check box on, the washer plate will be placed near the endplate, while turned off state of it indicates that the washer plate will be placed near the cover-plate. The check box will be active solely in case the cover-plate is placed into the complex element.

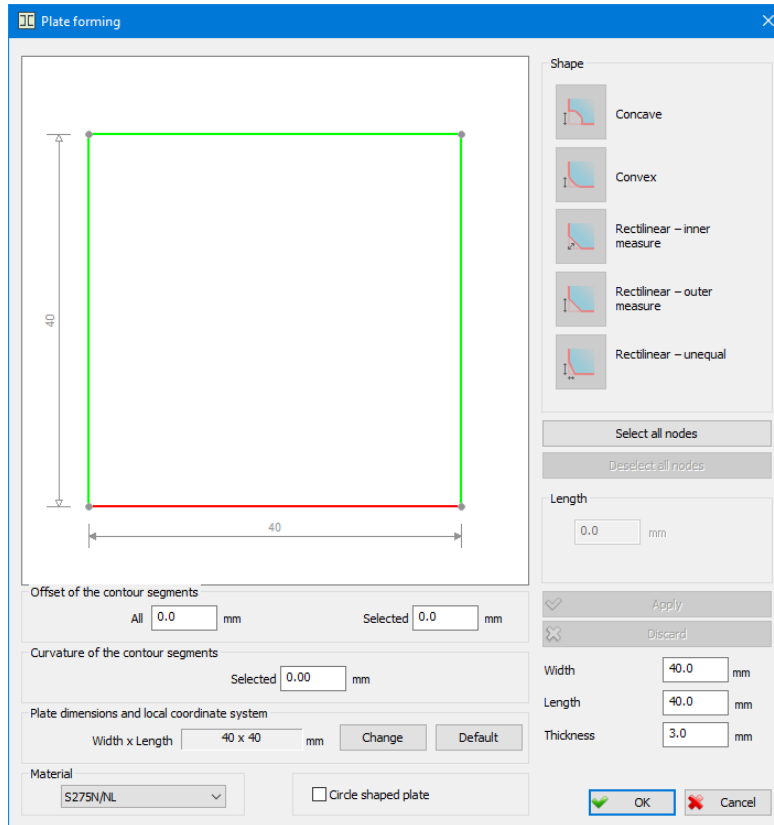

The dialog box for defining the washer plate

Width The edit box for assigning the washer plate width.

Length The edit box for assigning the washer plate length.

Thickness The edit box for assigning the washer plate thickness.

Circle shaped plate

The check box upon activating which the washer plate obtains the circular form.

Material The combo box for selecting one of previously defined steel categories.

Working within this dialog box is explained in detail in Chapter 4.3, and therefore will not be explained again.

By pressing the 'OK' button and exiting this dialog box, all the modifications in the dialog box will be accepted, and the user is returned to the main dialog box for defining the complex element, where all these modifications will be shown in the drawings.

Endplate The button that is active solely in case the 'Put in' is chosen from the combo box located on the left of it. By activating the button, the dialog box for defining the endplate opens up.

Visible

By turning this check box on, placed endplate will be shown in the drawings in the dialog box.

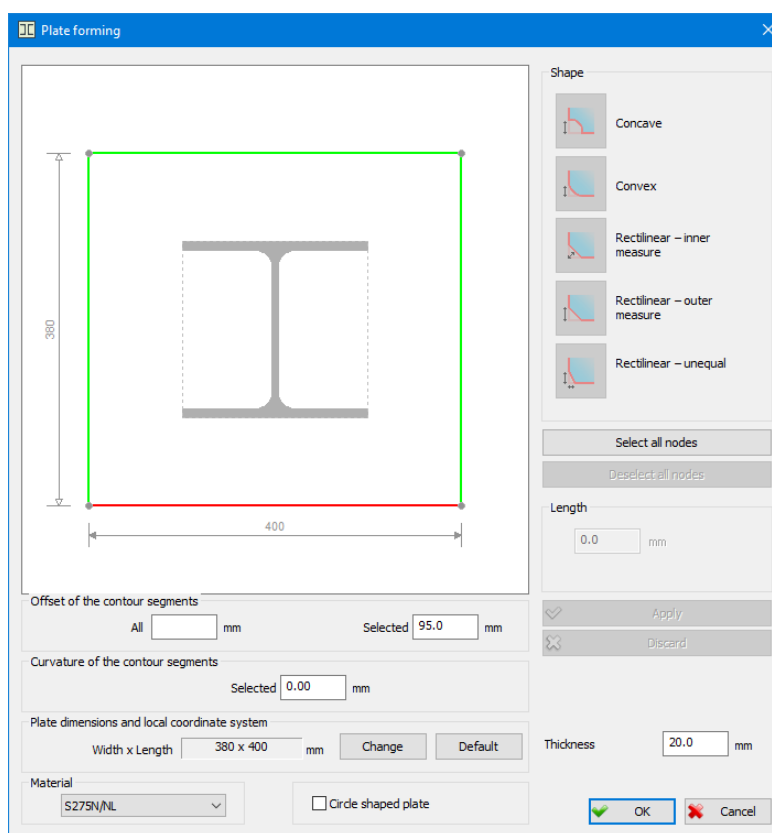

The dialog box for defining the endplate

Thickness

The edit box for assigning the endplate thickness.

Circle shaped plate

The check box upon activating which the endplate obtains the circular form.

Material

The combo box for selecting one of previously defined steel categories.

Working within this dialog box is explained in detail in Chapter 4.3, and therefore will not be explained again.

By pressing the '**OK**' button and exiting this dialog box, all the modifications in the dialog box will be accepted, and the user is returned to the main dialog box for defining the complex element, where all these modifications will be shown in the drawings.

Cover-plate

The part of the dialog box where the cover-plate is created. It is possible to choose one of the available geometric cover-plate types from the combo box:

Without cover-plate – the cover-plate is not placed into the complex element.

Single-sectioned – the single-sectioned cover-plate, with the rectangular hole corresponding to the size of column shape, is placed into the complex element.

Multi-sectioned -X direction – the two-sectioned cover-plate is placed into the complex element in X direction, with one part in front, and the other one behind the column.

Multi-sectioned - Y direction – the two-sectioned cover-plate is placed into the complex element in Y direction, with one part in front, and the other one behind the column.

Multi-sectioned – X direction with additions – the cover-plate that consists of two main sections in X direction, as well as two smaller sections in Y direction, for connecting the main cover parts, is placed into the complex element.

Multi-sectioned – Y direction with additions – the cover-plate that consists of two main sections in Y direction, as well as two smaller sections in X direction, for connecting the main cover parts, is placed into the complex element.

Single-sectioned with the circular hole – single-sectioned cover-plate, but with the circular hole corresponding to tubular and circular shapes is placed into the complex element.

Placement The edit box for assigning the value determining the distance of the cover-plate from the column end.

Visible By turning this check box on, placed cover-plate will be shown in the drawings in the dialog box.

Cover-plate The button active solely in case cover-plate placing is chosen from the combo box, that is located on its left. Activating of this dialog results in opening the dialog box for defining the cover-plate.

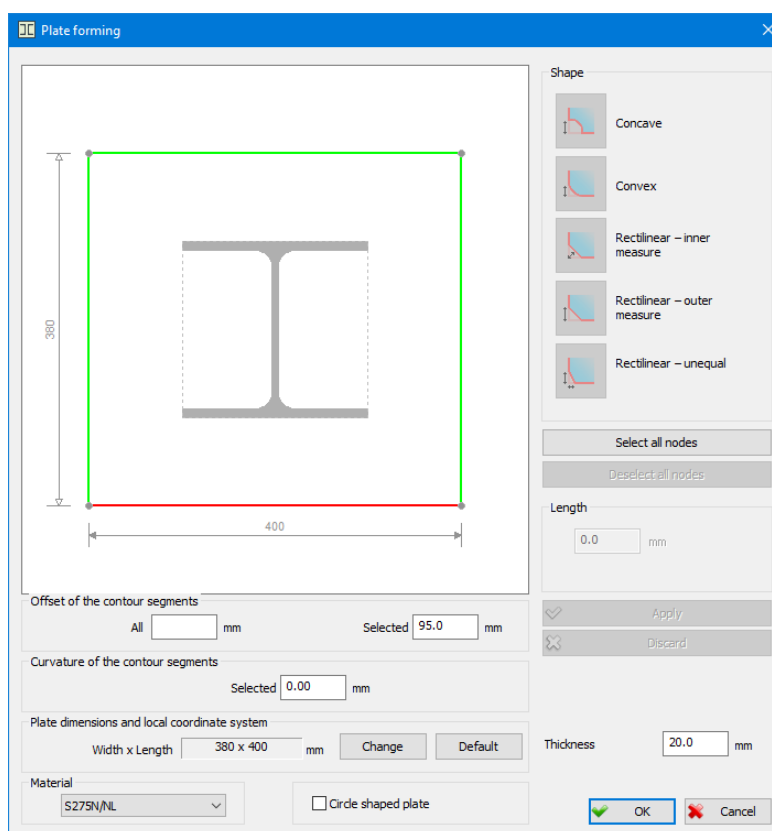

The dialog box for defining the cover-plate

Thickness The edit box for assigning the cover-plate thickness.

Circle shaped plate

The check box upon activating which the cover-plate obtains the circular form.

Material The combo box for selecting one of previously defined steel categories.

Working within this dialog box is explained in detail in Chapter 4.3, and therefore will not be explained again.

By pressing the '**OK**' button and exiting this dialog box, all the modifications in the dialog box will be accepted, and the user is returned to the main dialog box for defining the complex element, where all these modifications will be shown in the drawings.

Configuration:

Any previously saved configuration can be selected from this list to represent the current one.



Save

The configuration with the current state of parameters in the dialog box is saved in the database.



Delete

Deleting the current configuration from the database.

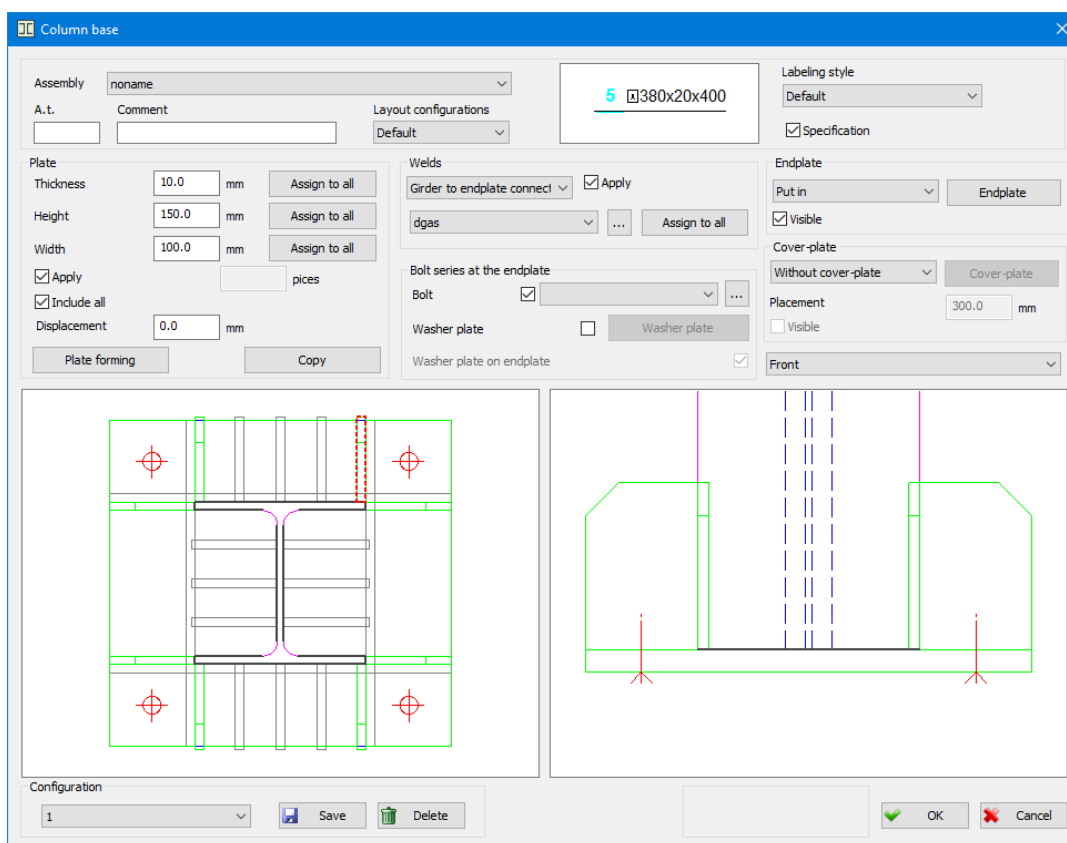

By pressing the '**OK**' button and exiting this dialog box, the complex element will be created in the drawing, based on the data assigned in the dialog box.

15.4 Beam to beam splice

This command allows you to create the field extension using plates and corresponding connection devices. It is obligatory that the beams the field extension is created for must be collinear, so the forming of this connection on the place of their joining can be feasible. Either by selecting the '**Beam to beam splice**' command from the '**Metal Studio ► Automatization**' drop-down menu or by clicking on the icon , the user is requested to select the first girder, with the command bar obtaining the following layout:

Selecting first girder [Exit] <Exit> :

Selected girder is marked in green, and afterwards, selecting second girder is expected:

Selecting second girder [Exit] <Exit>:

Upon choosing the second girder, the dialog box for creating the field extension where two selecting girders are connecting opens up:

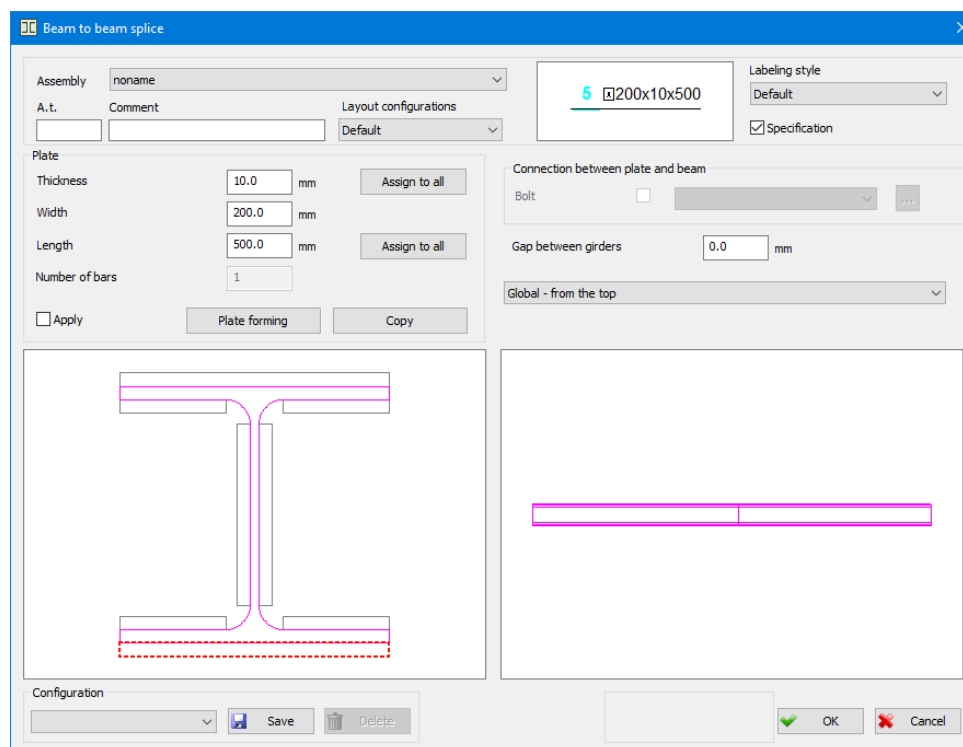

The dialog box for defining the Beam to beam splice – the layout

Lateral plan view of girders and initial plate positions are shown in the left drawing, while showing of the right drawing depends on the view chosen from the list above this drawing. All modification performed in the dialog box are automatically displayed in these drawings, which enables the user to have comprehensive and clear insight and easily work within the dialog box.

Data referring to all the elements, i.e. positions formed during the creation of complex element are show in the upper part of the dialog box.

- Assembly** The combo box for selecting some of previously defined assembly positions.
- A.t** The edit box for entering the **additional tag** of positions displayed in the label.
- Comment** The edit box for assigning the arbitrary comment of positions displayed in the label.
- Labeling style** From the combo box, you can chose one of previously defined label style configurations. 'Preview' located on the left from this box, displays the label layout, corresponding for the chosen style.
- Specification** The check box for determining whether the position is going into specification or not.
- Layout configurations** The combo box for choosing one of previously defined entity layout configurations.

- Plate** The part of the dialog box for defining the geometric characteristics of the lateral plates that will be the part of creating the field extension. In the left drawing, in the dialog box, position of all the plates located in this assembly is shown in gray. Hovering the mouse over them results in them changing the color, and when mouse pointer is placed above the plate, it is shown in yellow and may be selected by left-clicking it. Currently active plate is shown in red, and the right-clicking it with the mouse results in opening the drop-down menu with options for entering its geometry ('**Plate forming**'), copying of the plate geometry ('**Copy**'), as well as option for its placement into the field extension ('**Toggle inclusion**').
- Apply** The check box upon turning which the currently selected plate is set into the field extension and showed in green.
- Thickness** The edit box for assigning the currently selected plate thickness.
- Assign to all** By activating this button, located on the right from the exit box 'Thickness', the entered thickness value is assigned to all the plates
- Width** The edit box for assigning the currently selected plate width. The program automatically calculates the plate width, depending on the chosen shape, so that the plate placed near the beam web has the width identical to the web height, while the width of the plate near the flange is identical to the flange width. By entering the corresponding value in this edit box, the user is enabled to alter the width value, assigned by the program.
- Length** The edit box for assigning the currently selected plate length.
- Assign to all** By activating this button, located on the right from the exit box 'Length', the entered length value is assigned to all the plates
- Plate forming** The button upon activating which a dialog box for forming plates where the user can independently alter all the data in relation to the plate geometry, as well to form the plate, will open up.

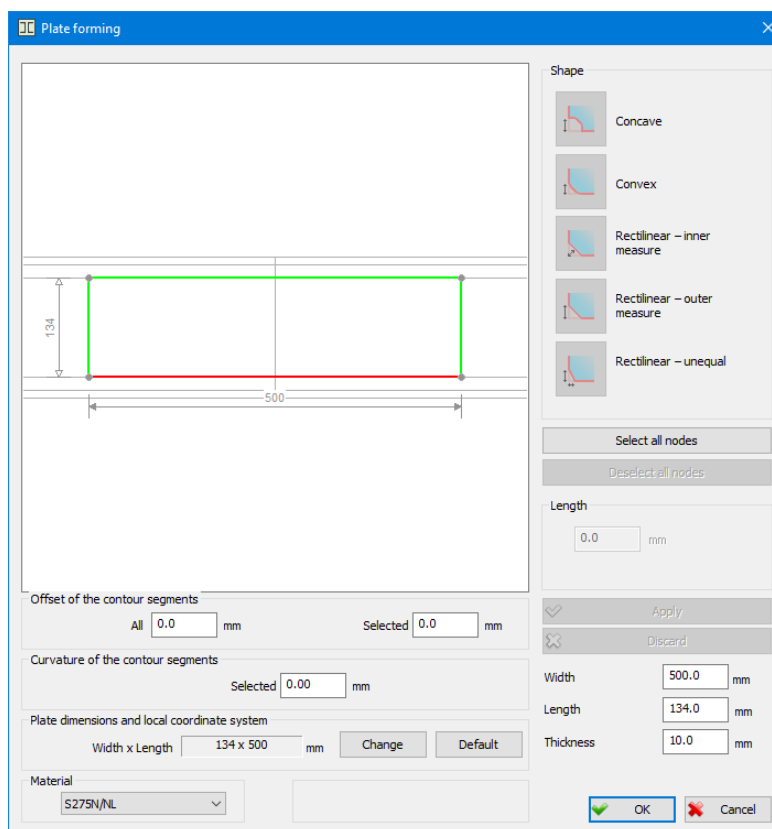

The dialog box for entering the geometry and plate forming

- Width** The edit box for assigning the plate width.
- Length** The edit box for assigning the plate length.
- Thickness** The edit box for assigning the plate thickness.
- Material** The combo box for selecting one of previously defined steel categories.

Working within this dialog box is explained in detail in Chapter 4.3, and therefore will not be explained again.

By pressing the '**OK**' button and exiting this dialog box, all the modifications in the dialog box will be accepted, and the user is returned to the main dialog box for defining the field extension, where all these modifications will be shown in the drawings.

Copy Considering the fact that field extension is generally created from the larger number of identical plates, the user is enabled to copy the defined plate geometry onto other plates. The plate whose data you want to assign to other plates must be selected in the left drawing in the dialog box, and afterwards choose the 'Copy' button, while its data will be copied, and the copied plate will be shown in white while the command is active. After that, it is necessary to place the mouse pointer above the plate you want to assign the data of copied plate to, and when it turns yellow, left-click it. The program will assign all the data of copied plate to the selected plate. The copying ends by left-clicking the empty space in the drawing.

Connection between plate and beam

The part of the dialog box where it is particularly defined, for every plate previously placed in the connection and marked in green, how its connection with beam is performed. It is necessary to firstly left-click and select the placed

plate from the left drawing in the dialog box. The selected plate is marked in red. In case the plate is not connected, this part of the dialog box will be inactive. In case the selected plate is connected, this part of the dialog box becomes active and all the modifications in it will refer solely to the connection between selected plate and beam. The user is now enabled to place the connection devices where selected plate and beam are connected.

Bolt

By turning this check box on, a bolt series is placed where the selected plate (plate selected from the left drawing in the dialog box) and beam are connected, and the list located on the right from this check box becomes active and any previously saved configuration can be selected from this list to represent the current one.



Button upon activating which the dialog box for assigning all the parameters necessary for defining the bolt series opens up.

Configuration:

Any previously saved configuration can be selected from this list to represent the current one.



Save

The configuration with the current state of parameters in the dialog box is saved in the database.



Delete

Deleting the current configuration from the database.

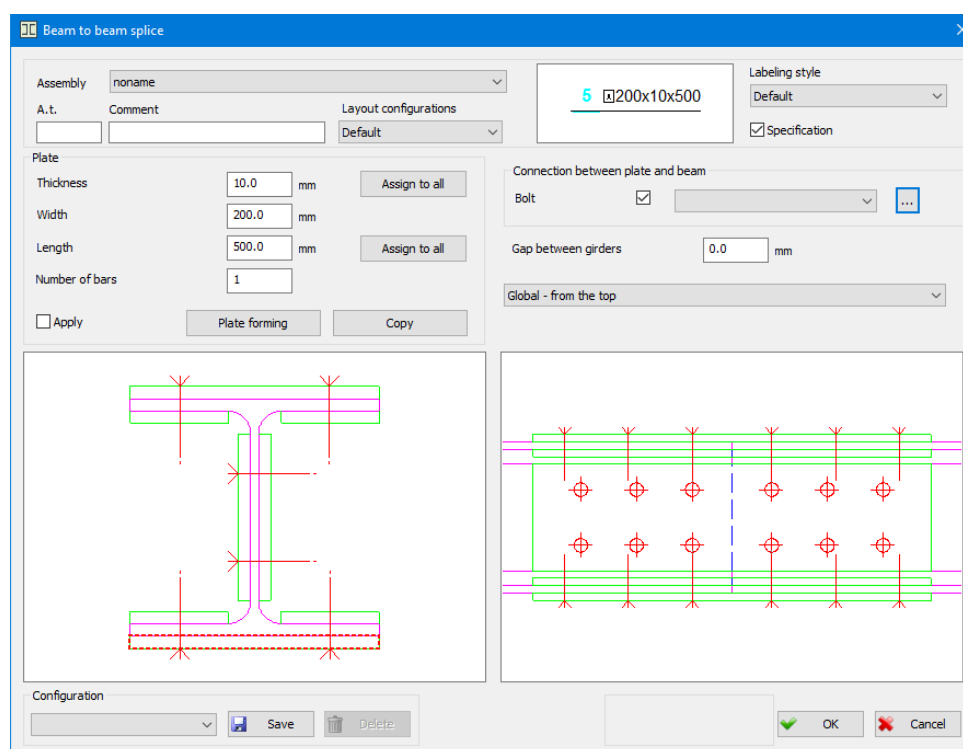

By pressing the '**OK**' button and exiting this dialog box, the field extension will be created in the drawing, based on the data assigned in the dialog box.

15.5 Edit of complex elements

The **'Edit of complex elements'** command allows you to alter all the data of previously created complex element. Either by selecting this command from the **'Metal Studio ► Automatization'** drop-down menu or by clicking on the icon , the command bar obtains the following layout:

Selecting an entity [Exit] <Exit>:

Now you must select the desired complex element from the drawing, and afterwards, the program calls the command that was used to place the given element in the drawing. Within the dialog box opening after this action, all the parameters are placed to the same state they had before the creation of complex element, and the user is now enabled to perform their modification.

In case, e.g. the 'beam to beam splice' is selected from the drawing, the following dialog box will open up:

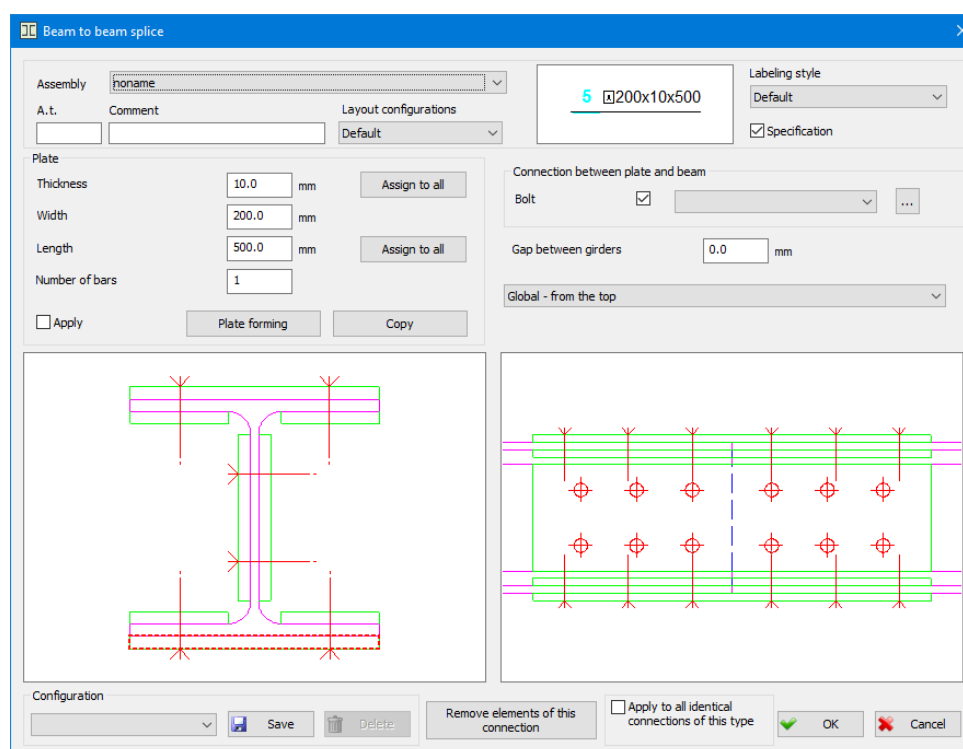

This dialog box is identical to the dialog box opening during the creation of the field extension, and it can be used for unlimited modification of all the previously assigned data.

Remove elements of this connection

The button upon activating which the complex element, i.e. all the elements placed in the drawing by creating this connection, will be removed. The following warning appears during this action:

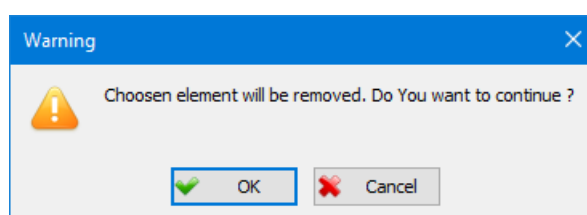

By activating the 'Ok' button, selected complex element will be removed from the drawing.

Apply to all identical connections of this type

The most common case in practice is that the same complex element, with identical data in the dialog box, is placed to several positions in the drawing. By turning this check box on, all the modifications in the dialog box will be applied not only to the selected complex element, but also to all the complex elements created with the same data. In case the check box is turned off, all the modifications in the dialog box will be referring solely to the selected complex element.

In case, during the selection of complex element, the program discovers that some of the input data is changed, the following warning appears:

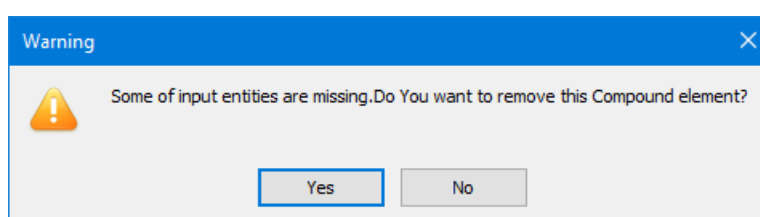

Yes The button upon activating which the complex element, i.e. all the elements placed in the drawing by creating this connection, will be removed.

No The button upon activating which the complex element remains in the drawing, but the dialog box for its arrangement will not open.

16. 3D MODELING - VIEWPORTS AND VIEWS

16.1 Assigning Viewports (AutoCAD's Viewports command)

Viewports in AutoCAD can be specified in several ways. The first is when the 'Viewports' item is selected from the 'View' drop-down menu, and then the 'Named Viewports...' item is selected from the new menu.

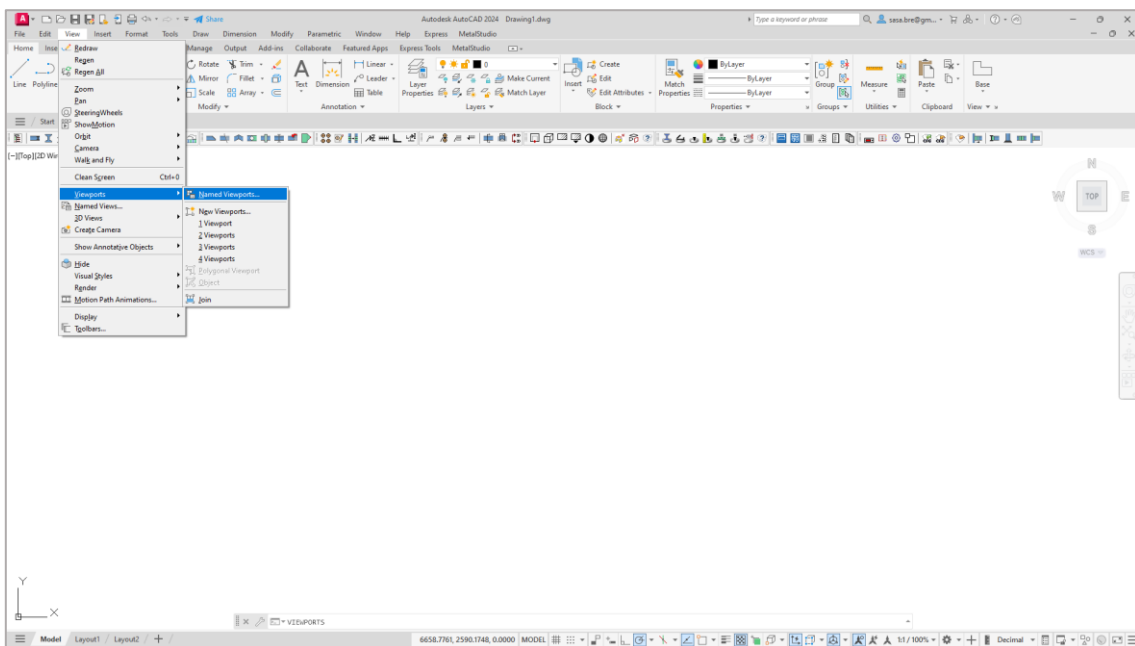

Selecting the 'Named Viewports...' command from the 'View' drop-down menu

Running the command opens a dialog that looks like this:

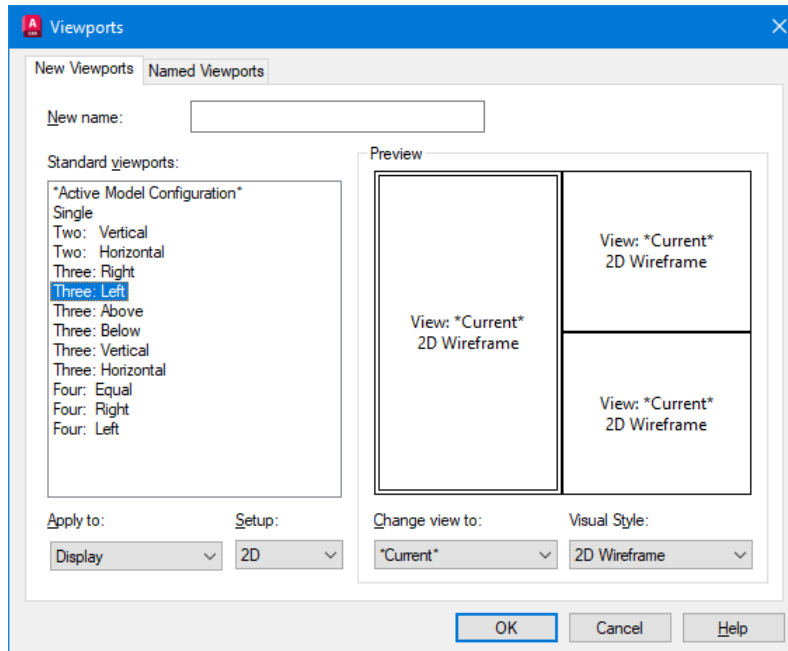

New Name – assigning a name to the new view configuration. If no name is given the viewport configuration will be applied but not saved.

Standard Viewports - a list from which one can choose one of the offered standard viewport configurations.

Preview – part of the dialog in which the layout of views from the selected configuration is displayed.

To work in the Metal Studio program, it is enough to select one of the standard configurations and exit the dialog. Other important parameters for each of the views will be defined using the 'Create and edit views' command.

Some of the offered standard viewport configurations can be selected directly from the 'Viewports' menu, without opening a dialog.

Also all these commands are available through the 'View' panel:

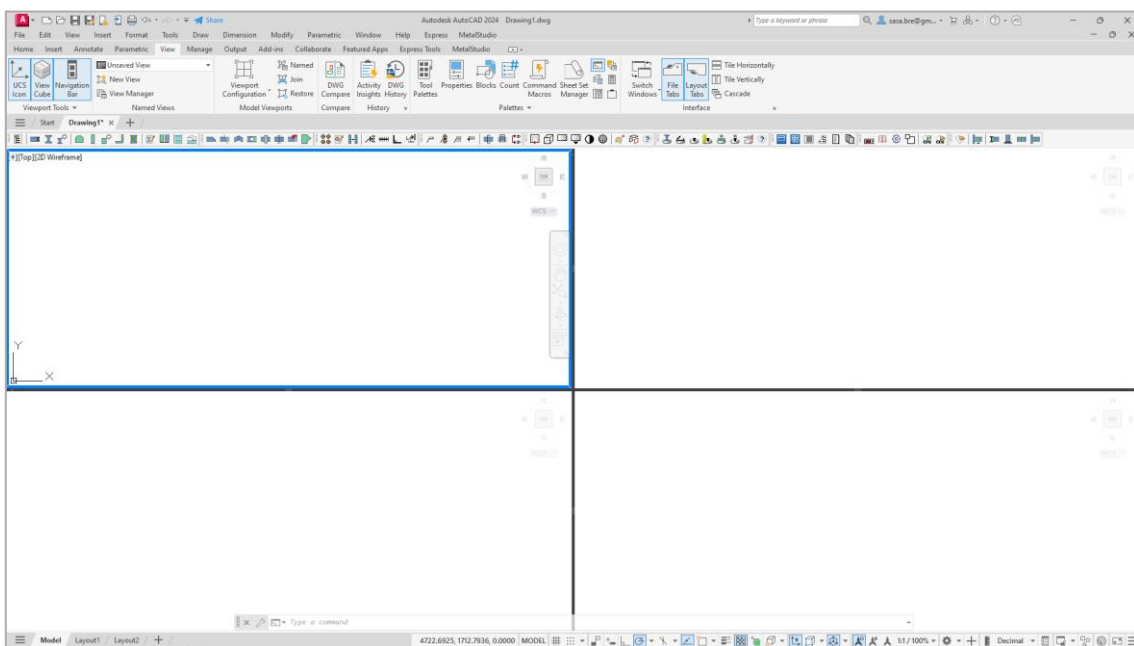
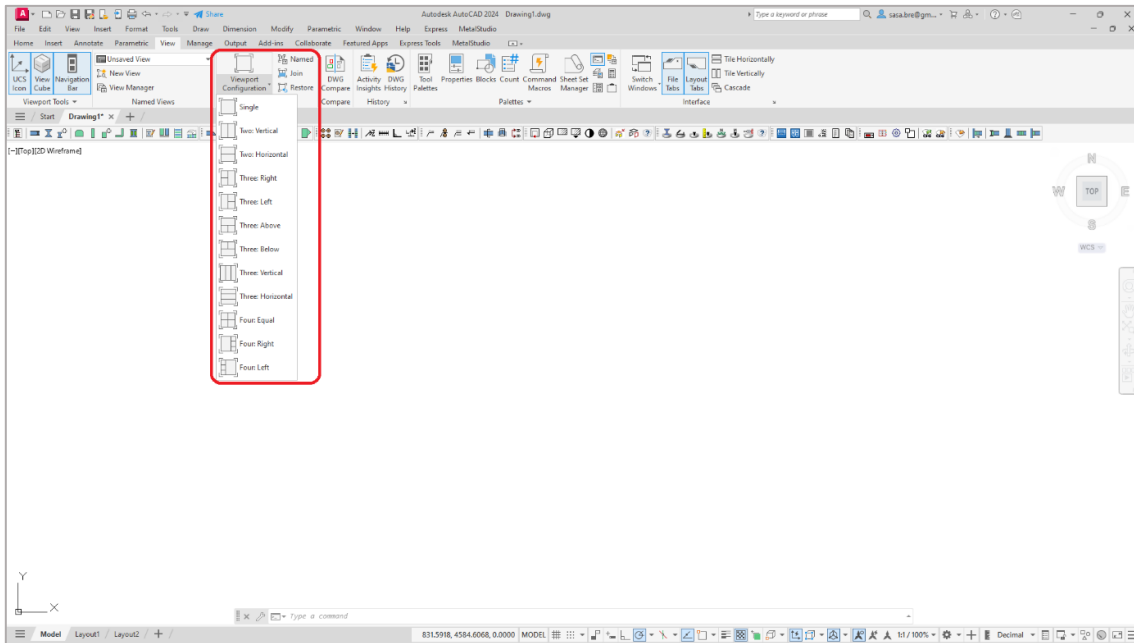

A configuration with four viewports of the same size was chosen

16.2 Change of operating mode: 3D Modeling <--> 2D Preparation

Using the command '**Change operating mode**', the operating mode of the program 'Metal Studio' can be changed at any time. Selecting it from the 'Metal Studio' drop-down menu or clicking on the icon  will open a dialog with the corresponding question. If the current mode is '2D Preparation', the following dialog will open:

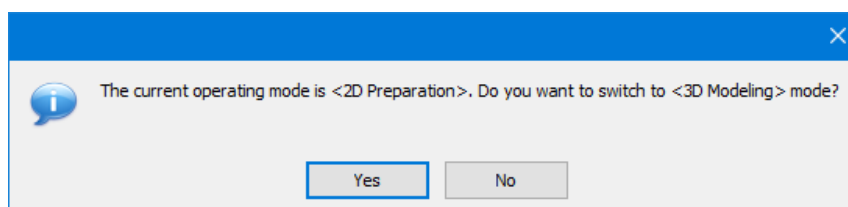

Clicking the 'Yes' button will switch to the '3D Modeling' mode. And if the current operating mode is '3D Modelling', a dialog will open with the following appearance:

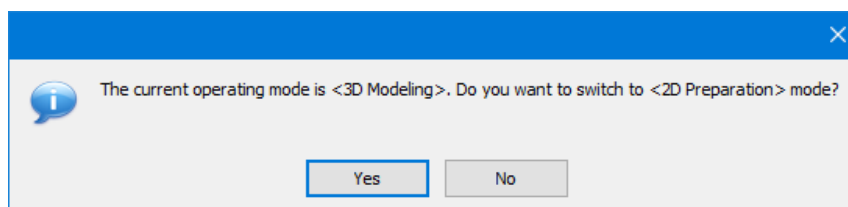

Clicking the '**Yes**' button will switch to the '2D Preparation' operating mode.

16.3 Creating and editing views

By selecting the command '**Creating and editing views**' from the '**Metal Studio**' drop-down menu or by selecting the icon , a dialog opens in which it is possible to define '2D views' and place them in viewports.

In case you are in the mode of the 2D preparation program, in which it is not allowed to define views, the program will first show the appropriate message:

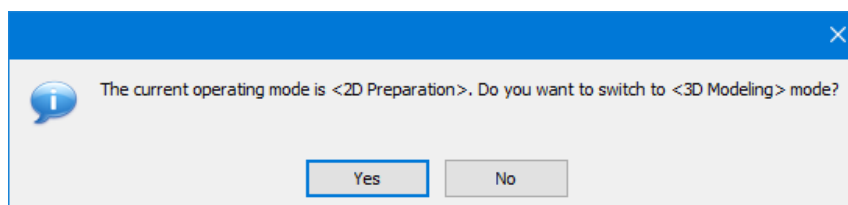

By selecting the '**Yes**' button, the program will switch to 3D modeling mode and open a dialog for creating and editing views:

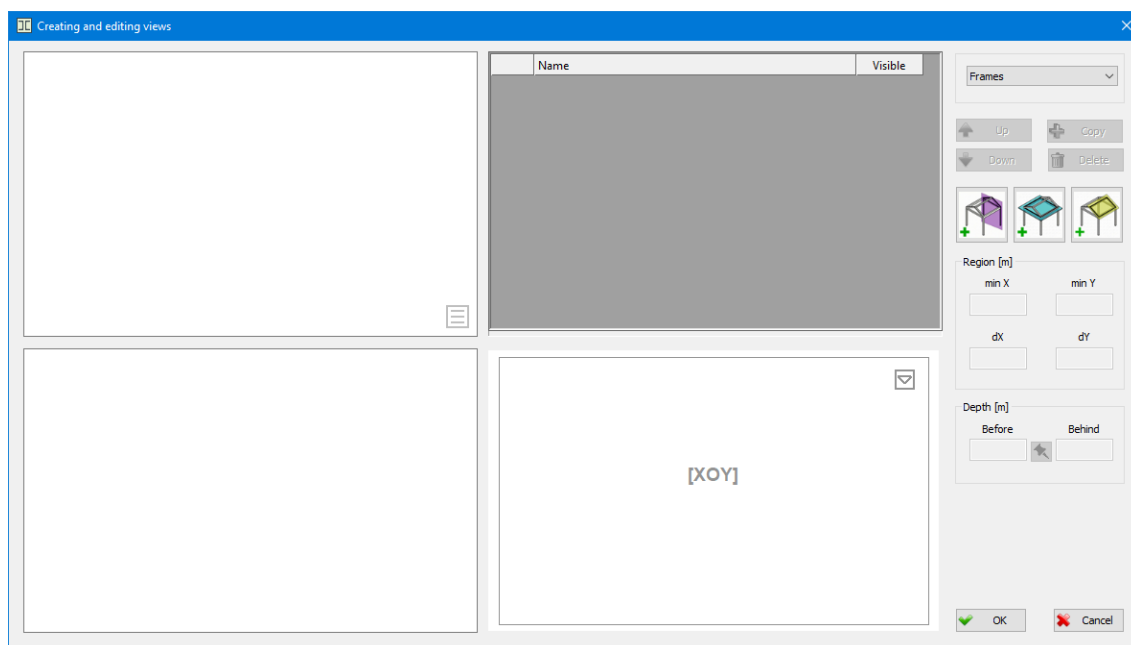

Dialog layout for creating and editing views

In the Metal Studio program, you can work with more than one view. Different assemblies can be displayed in them at the same time: frames, levels and oblique views. This feature of the program significantly facilitates the selection of points when drawing the model and provides greater visibility to different parts of the structure. In the lower part of the dialog, there is a space reserved for the display of the screen layout, i.e. the view layout, which the user previously defined.

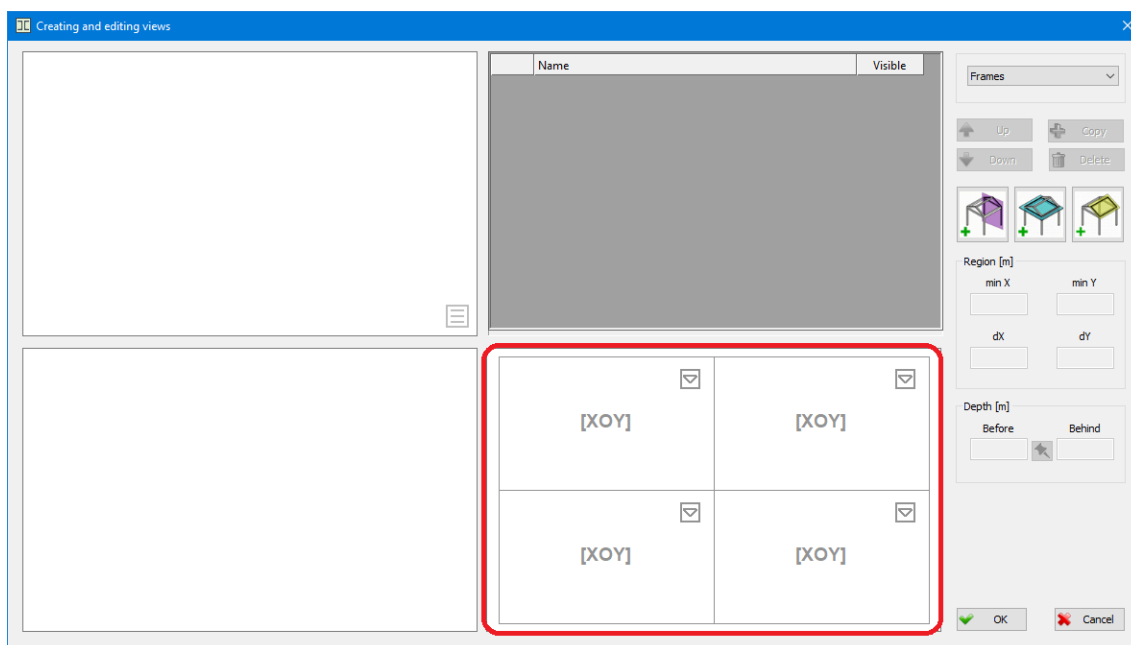

AutoCAD defaults to four viewports, the layout of which is shown in the dialog

The user can assign the desired view to each of the viewports. Upon right-clicking the mouse over the field in which the given viewport is displayed, a menu appears from which the user can choose one of the previously defined viewports, as well as two programmatically defined viewports: '**3D**' and the canonical '**XOY**'. In case the user has not created '2D views', only '3D' and canonical 'XOY' views will be found in the menu.

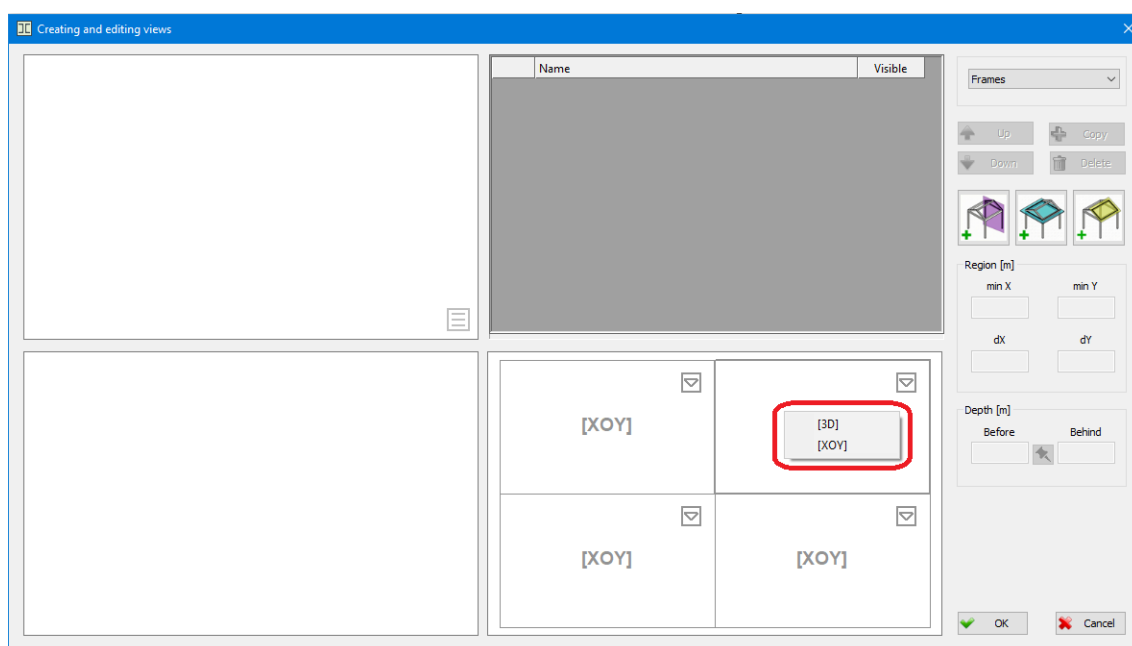

A view selection drop-down menu, which is assigned to the selected viewport

Creating '2D viewport'

The program allows the creation of '2D view', located in vertical, horizontal or oblique planes using one of the three buttons, located in the upper right part of the dialog:

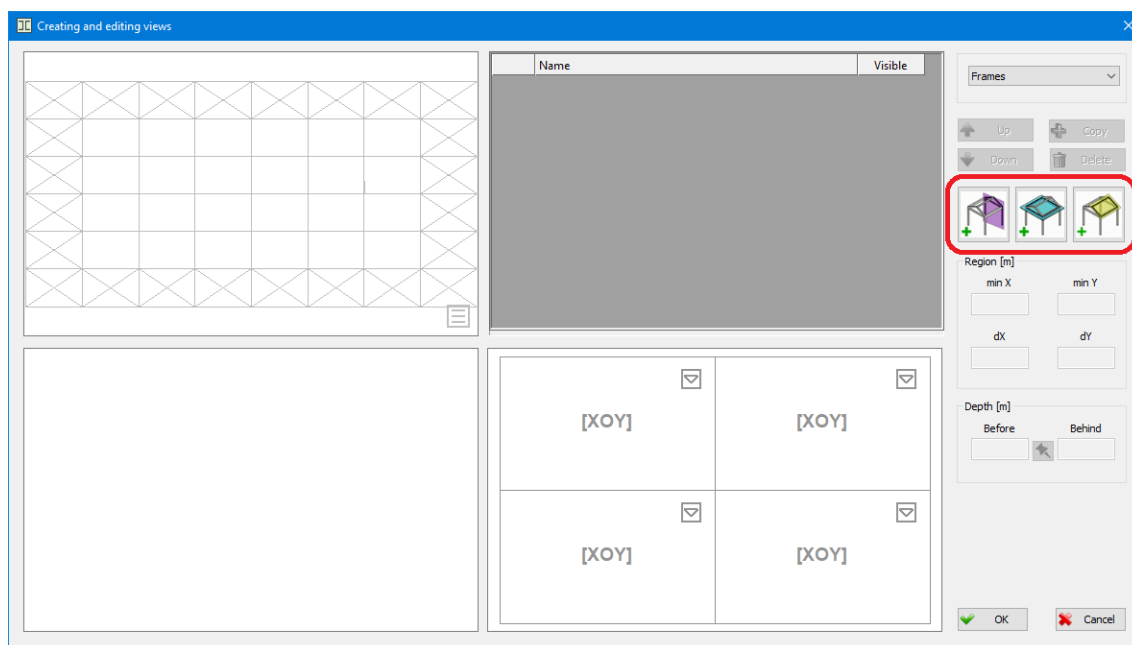

Command fields for creating '2D view'



With the command '**New frame**' you have the possibility to define a completely arbitrary position of the new frame. After activating the button, the program closes the dialog, and the command line takes the following form:

Select the lines [Exit]:

This message will remain on the command line until you complete the line selection procedure by selecting the 'Exit' sub-option or right-clicking the mouse, after which the dialog will open again. The user is expected to select AutoCAD lines or girders drawn in the Metal Studio program on the drawing in one of the views, whose position will determine the vertical plane, that is, the frame. As each of the frames in the drawing can be represented by only one segment, if more lines or girders are selected, the program will create the same number of new frames. Each of the created frames will be associated with a programmatically assigned name that will be displayed in the dialog. After selecting lines or girders, the program returns to the dialog for creating and editing views:

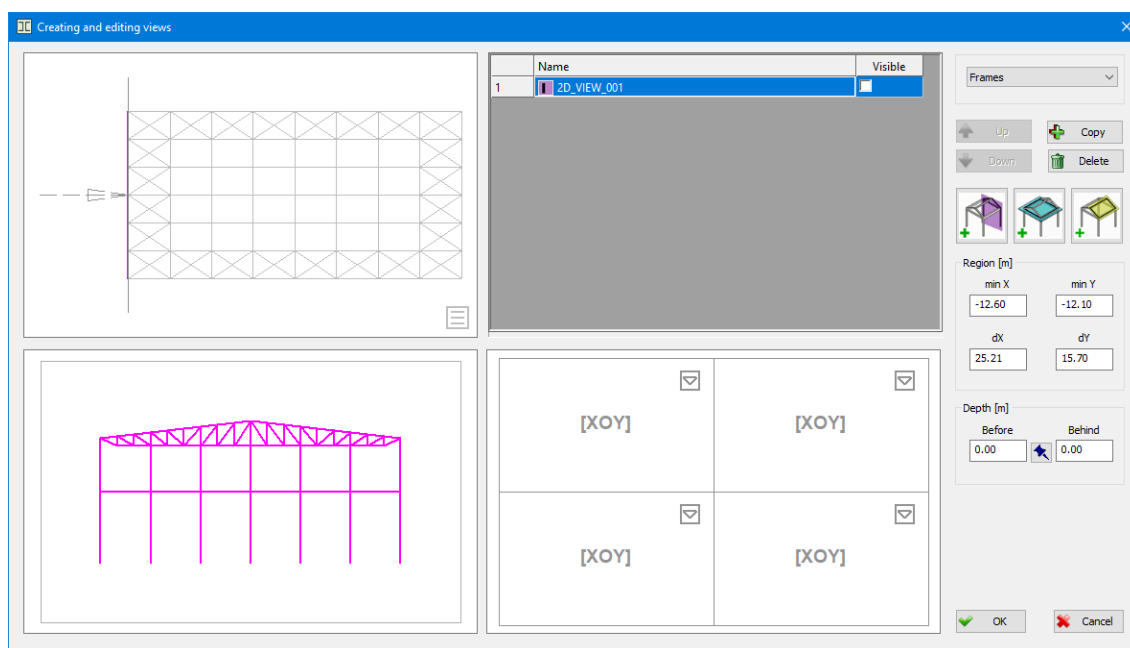

A new frame '2D_VIEW_001' has been inserted into the list

In the central part of the dialog, a list of '2D views', created by the user, is displayed.

Name Column named '2D views'. When creating views, the program automatically generates their names, which the user can subsequently modify.

Visible Column with check boxes. By setting the check box to the on state, in the window to the left of the list of views, in addition to the entity, the plane of the selected '2D view' will be drawn. By right-clicking on the column name, a drop-down menu with options appears:

Turn all on A button which, when activated, includes all check boxes in the list.

Turn all off Button, when activated, turns off all check boxes in the list.

Turn on selected Button, when activated, the check boxes of the selected views in the list are included.

Turn off selected Button, when activated, the check boxes of the selected views in the list are turned off.

If you want to make a copy of the currently selected view, you need to activate the button 'Copy'. Deleting the selected view from the list is done by selecting the button 'Delete'. Using the commands 'Up' and 'Down' you have the option to change the order of the views in the

list. Namely, selecting one of these command fields moves the currently selected view in the list one place up or down.

Given that the list can contain a large number of '2D views', for better visibility, the user is enabled to choose from the closed list, set only one of the offered types of views: '**Frames**', '**Levels**', '**Inclined views**' or '**All**'.

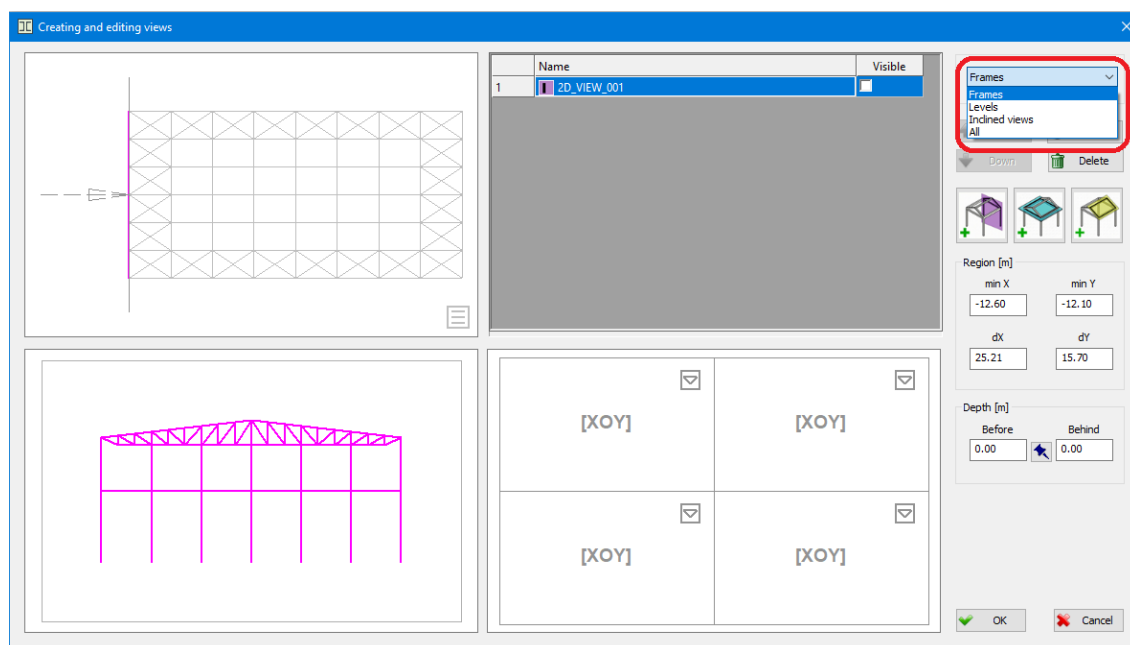

List from which to select the type of view to display in the table

If the type of view 'Frames' is selected, the table will display all '2D views' located in vertical planes, if 'Levels' is selected, all '2D views' located in horizontal planes will be displayed, and selecting 'Inclined view' will display all '2D views' located in arbitrary inclined planes. If you want to display all previously created views in the table, select '**All**' from the list.



Using the '**New Level**' command, the position of the horizontal plane is defined, whose position in space is determined by the global Z coordinate. After activating this command field, the program closes the dialog and from the command line requires the user to enter a point by specifying the coordinates from the keyboard or to select a point from the drawing where he wants to set the level:

Point:

After setting the point, the dialog will be opened again, and a level will be added to the list, which is associated with the name given by the program:

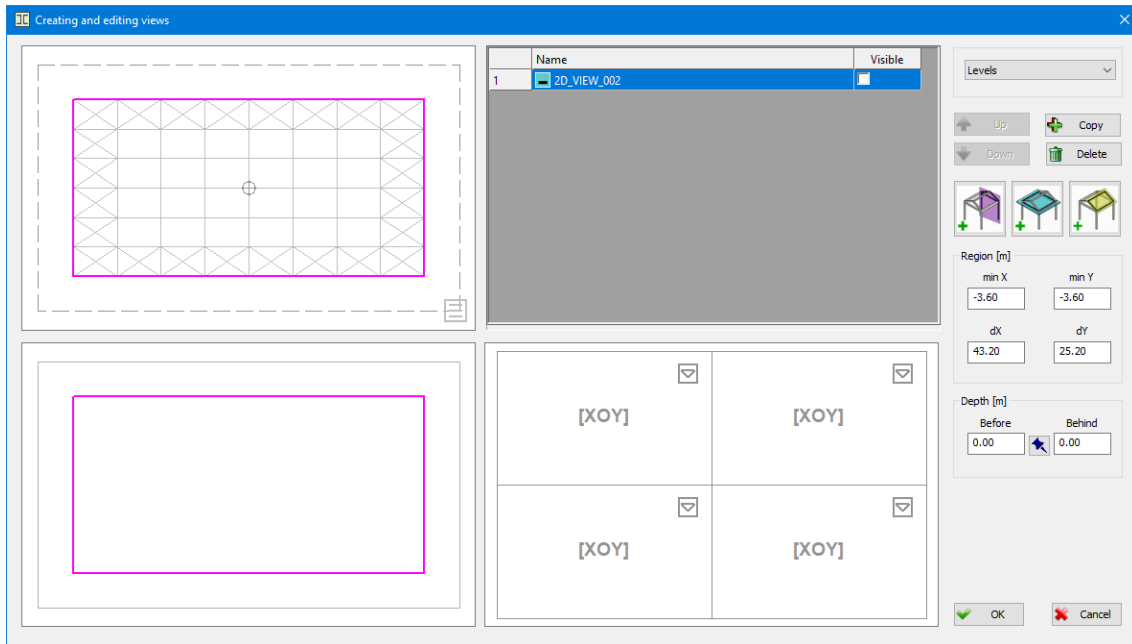

A new level '2D_VIEW_002' has been inserted into the list



Selecting the '**New oblique view**' command enters the procedure of defining a completely arbitrary view plane.

Three points [Selecting girder or plate]:

The program from the command line requires you to select the first point that defines the desired plane, and by selecting the sub-option 'Selection of girder or plate' you can enter the procedure of defining the view plane by selecting an existing entity, which can determine the position of the given plane.

Selecting girder or plate [Exit]:

So, the program provides two ways to define the desired plane. The first is by selecting three non-collinear points, and the second is by selecting an existing entity. In the event that you select points and entities in such a way that the plane containing the selected entity or points cannot be created, the program will issue a corresponding warning:

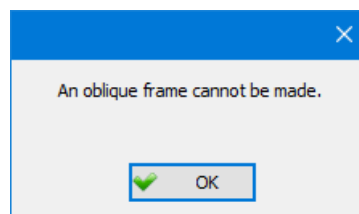

When the program determines that a sufficient number of elements that define a plane have been entered, the dialog will be opened again, and an oblique view will be added to the list, to which the name assigned by the program is attached:

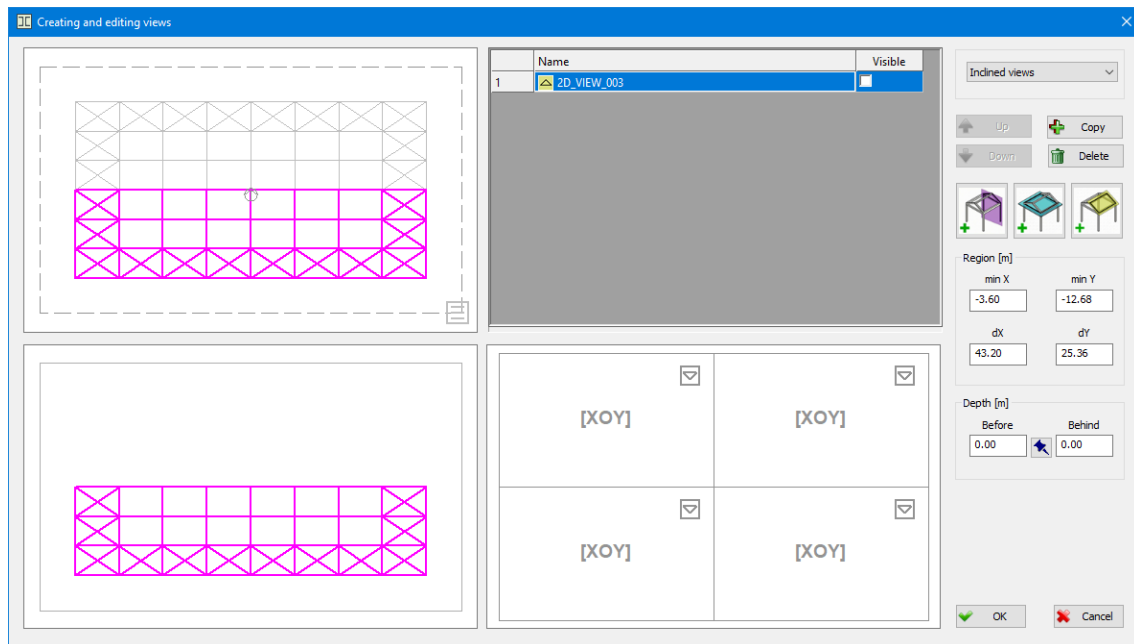

A new oblique view '2D_VIEW_003' has been inserted into the list

In the upper left part of the dialog, there is a window that is reserved for the schematic representation of the geometry of the positions of the rods and sheets that are in the drawing. Entities belonging to the currently selected '2D view' in the list are drawn with their parameters, while other construction elements are drawn in gray. In this way, the current '2D view' is visually separated from the rest of the spatial model.

Right click on the icon '☰' in the lower right corner opens a menu to set the default view.

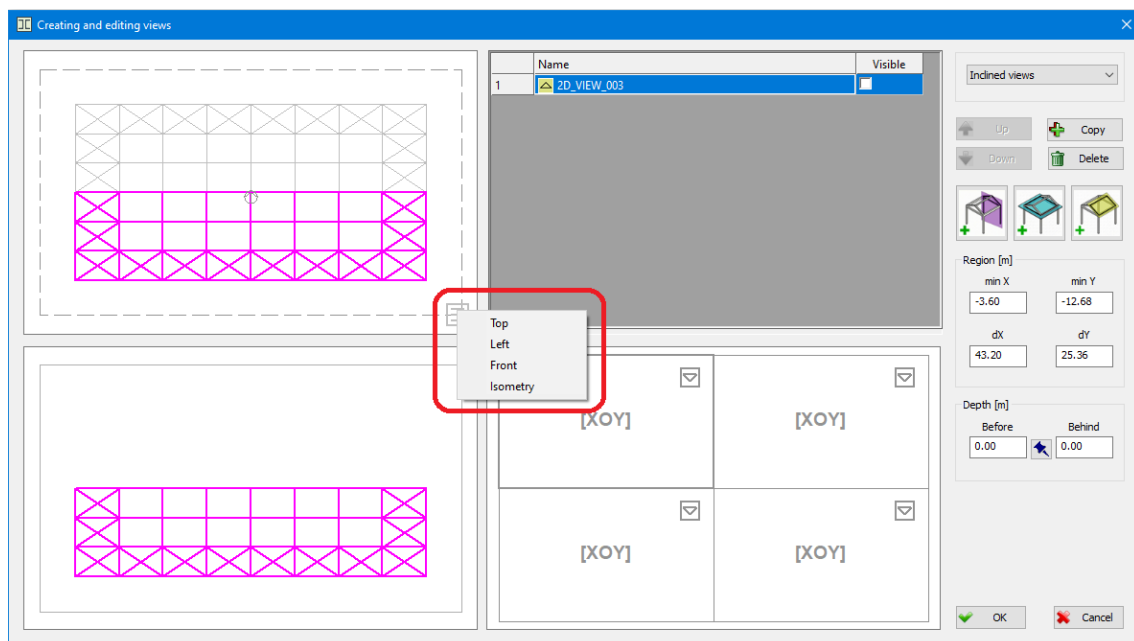

Drop down menu to choose a view

By selecting one of the views 'Top', 'Left' or 'Front', a view of the geometry of the positions from different sides is enabled, while by selecting the view 'Isometry', an isometric view is enabled.

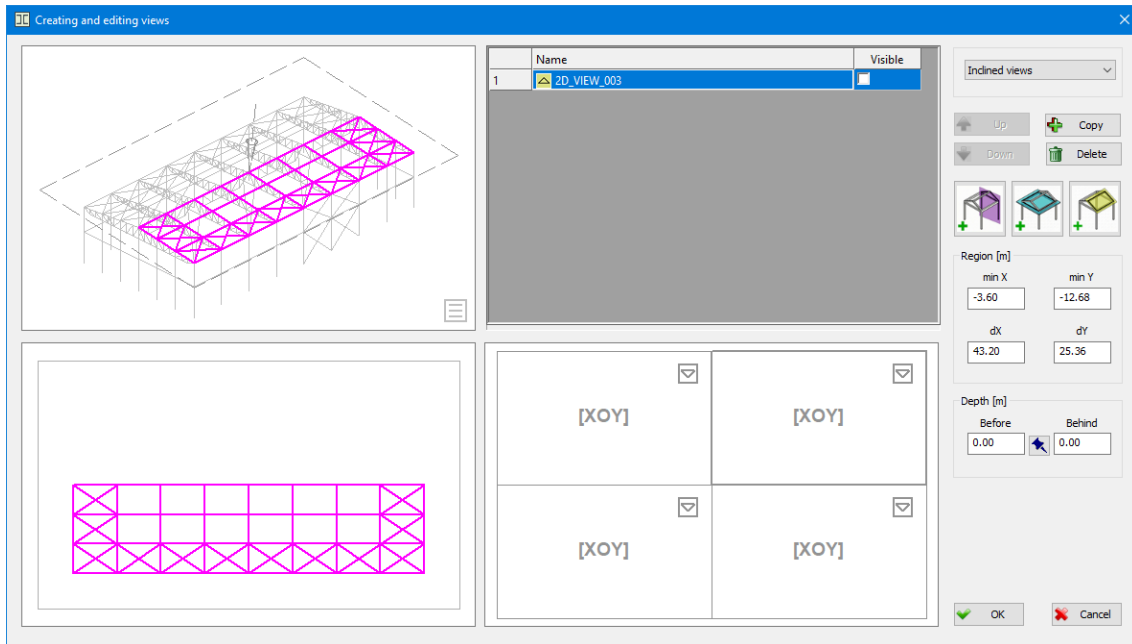

An isometric view is placed in the left window

Assigning a '2D view' can also be done directly from the view creation and editing dialog. First, it is necessary to select a girder in the lower left window by clicking the mouse, which, in addition to the currently selected '2D view' in the list, also belongs to the view that you want to assign. The selected girder will be specially marked on the drawing in the dialog. After that, from the menu that opens with the right click of the mouse, you should select the command 'Make a perpendicular view'.

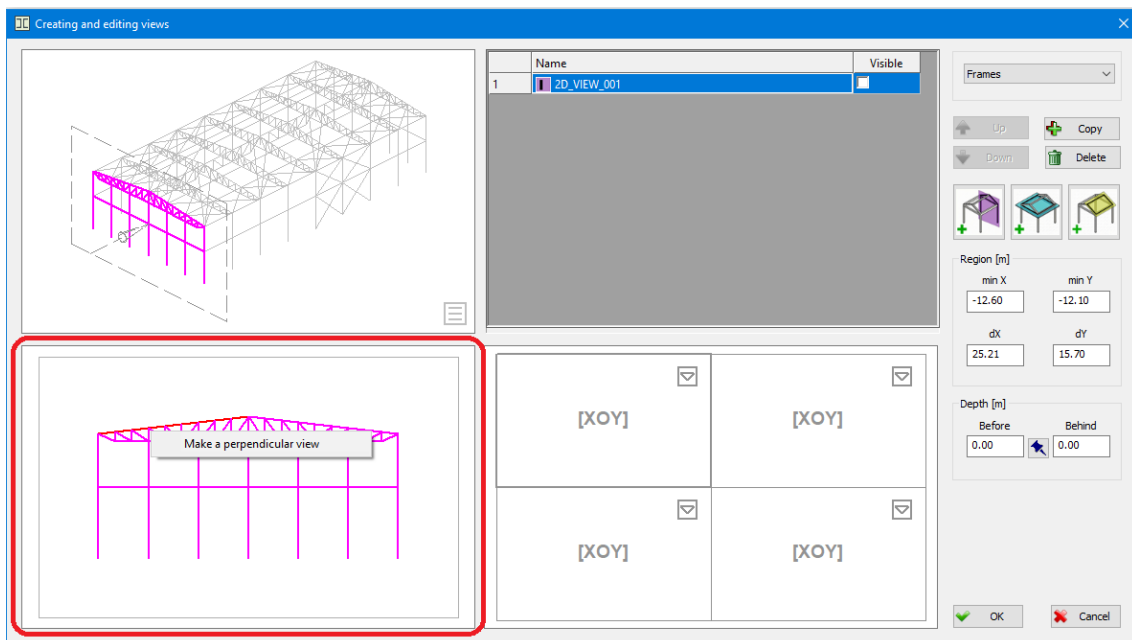

Command to make a perpendicular view from the currently selected girder

Selecting the 'Make a perpendicular view' command will create a new view, which will be displayed in the dialog:

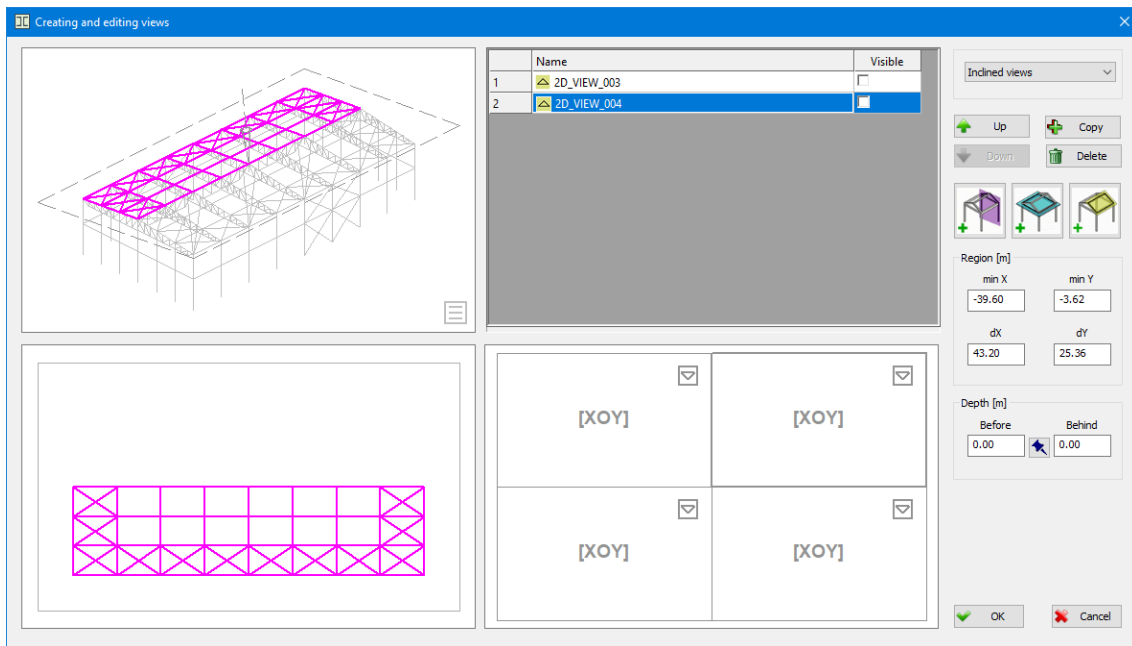

A new oblique view '2D_VIEW_004' has been inserted into the list

Placing the created '2D views' in viewports

We have already said before that all created '2D views' can be placed in viewports. First, in the list of views for the current one, select the '2D view' that you want to place in the viewport, and then from the menu that opens when you right-click on the currently selected viewport, select the given view.

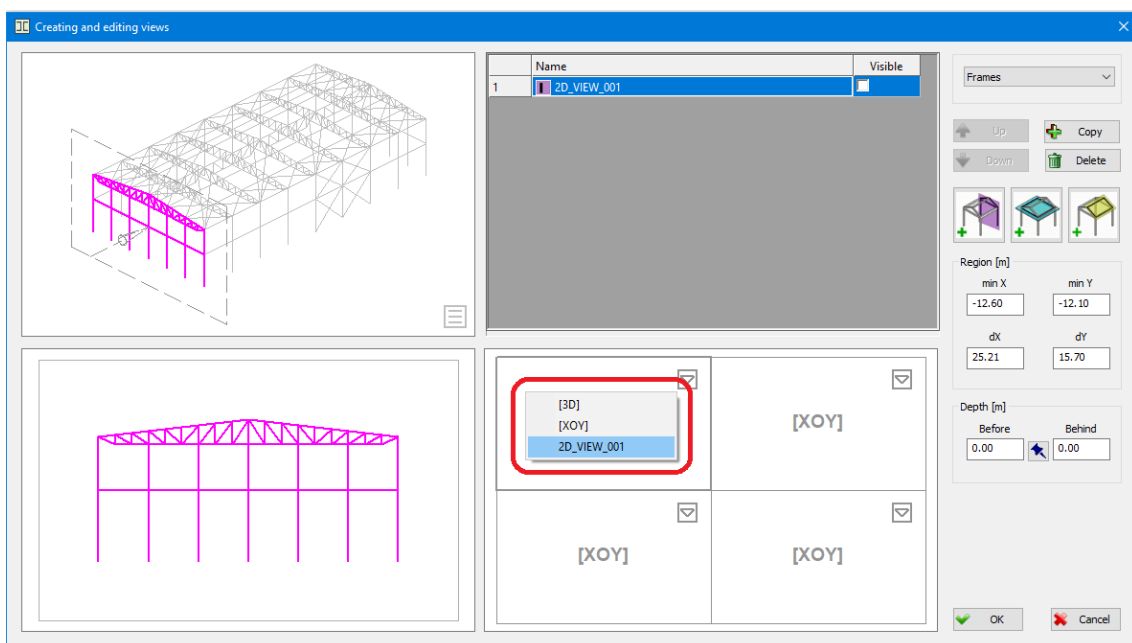

The currently selected '2D view' is in the drop-down menu

After selecting '2D view' from the drop-down menu, the given viewport will be placed in the selected view, and the cell with the ordinal number of the view in the list and the icons in the viewport will be specially marked:

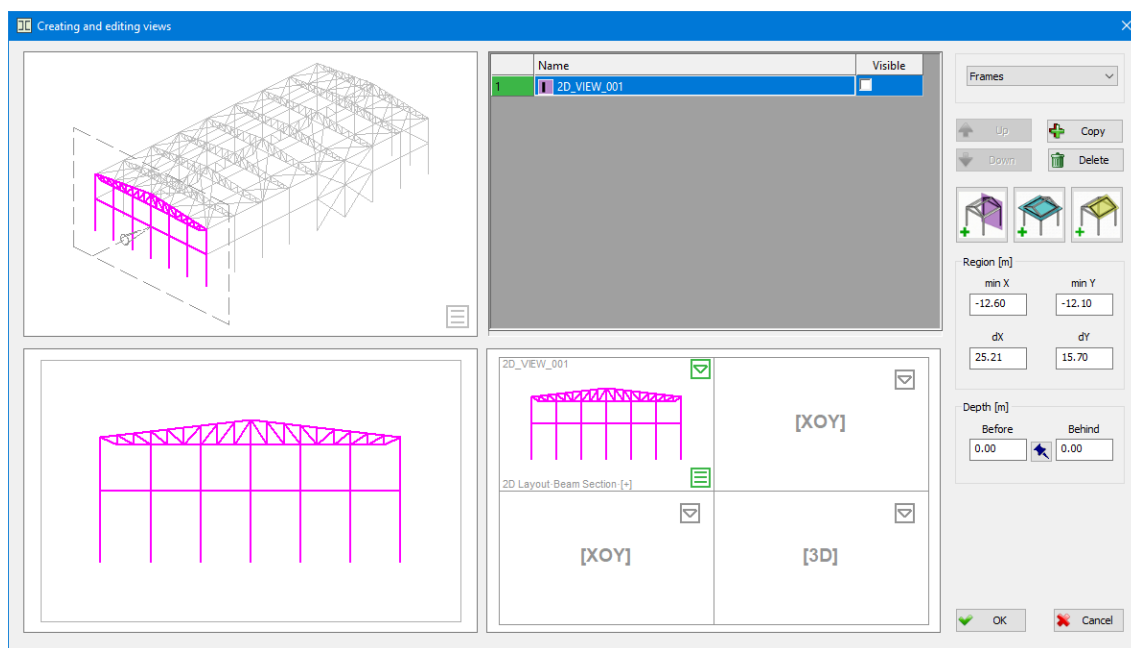

Frame '2D_VIEW_001' is placed in the upper left viewport

In the upper left corner of the window in which the viewport is displayed, the name of the set viewport is printed, while at the bottom, information about the viewport setting is displayed: the type of view, the way indirect elements are displayed, as well as the viewing direction.

By clicking the icon '☰', a dialog opens in which the viewport setting is made:

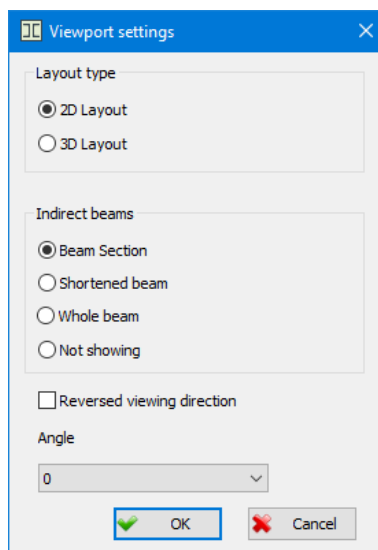

Viewport settings dialog

2D Layout The on state of the switch indicates that beam and plate instances in the viewport will be rendered as intangible.

3D Layout The on state of the switch indicates that beam and plate instances in the viewport will be rendered as material.

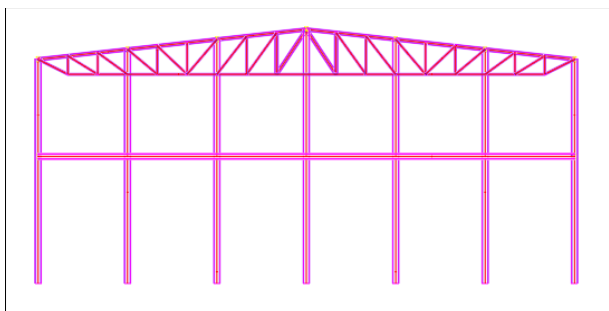

Display of beams when '2D Layout' is on

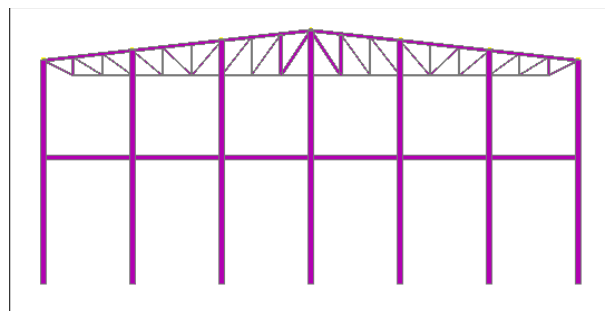

Display of beams when '3D Layout' is on

In the 'Indirect beams' section of the dialog, the way to display indirect beams in the viewport is determined:

Beam section

The on state of the switch indicates that instances of indirect beams will be rendered as intangible beam sections.

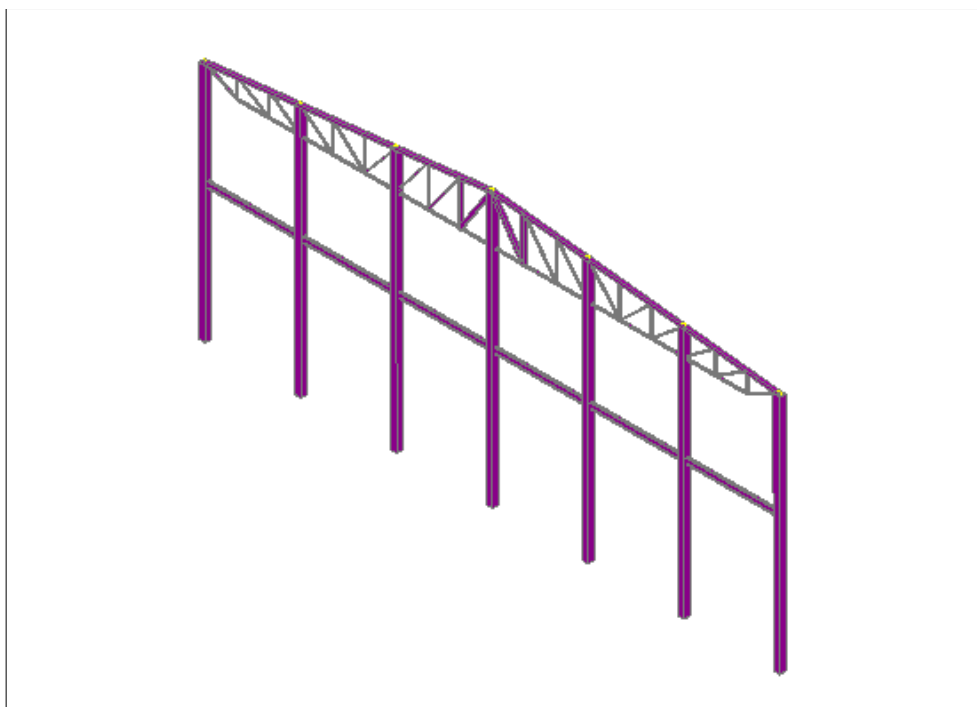

Shortened beam

The on state of the switch indicates that material instances of indirect beams will be rendered as material beams with a length truncated by the given depth of viewport.

Whole beam

The on state of the switch indicates that instances of indirect beams will be rendered as beams at their full length.

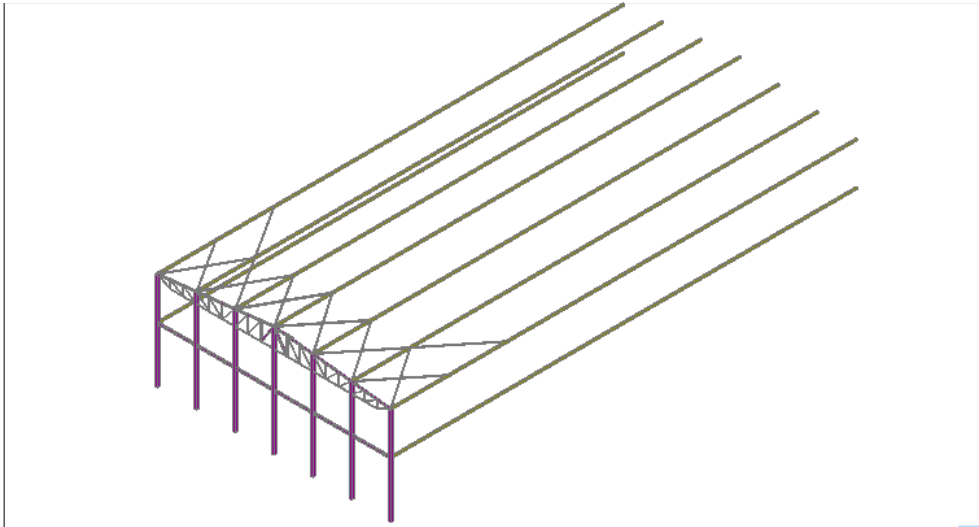

Not showing

The on state of the switch indicates that material instances of indirect beams will not be displayed.

Reversed viewing direction

By means of the check box '**Reversed viewing direction**', the user is enabled to adjust the viewing direction of the viewport.

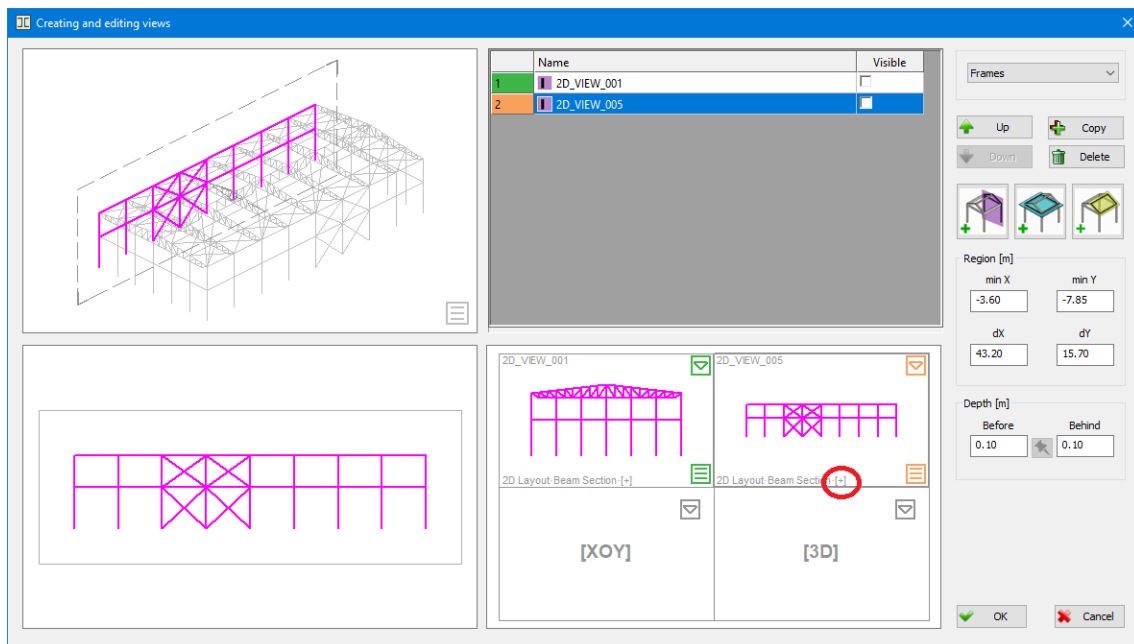

A label indicating that the 'Reverse viewing direction' check box is off

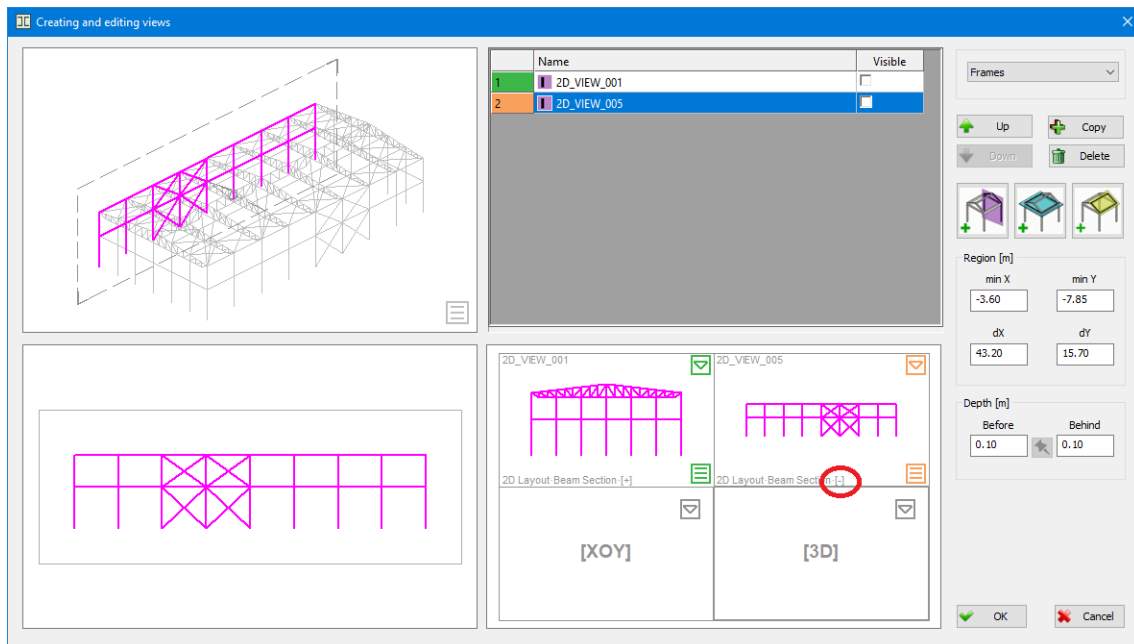

A label indicating that the viewing direction has been changed

Angle A closed list from which to choose one of the four offered angles for which the '2D view' will be rotated in the viewport.

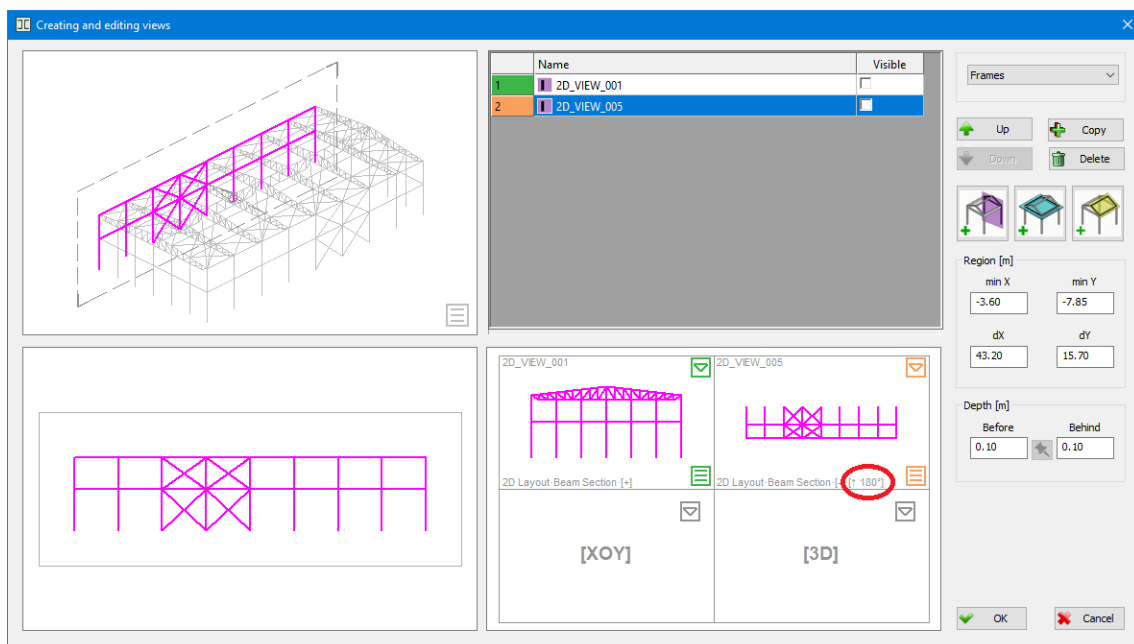

The '2D view' is given a rotation angle of 180°

In the Metal Studio program, it is possible to set the depth of viewport, so that it will display only entities that enter the space defined by the user by setting values in the corresponding edit boxes.

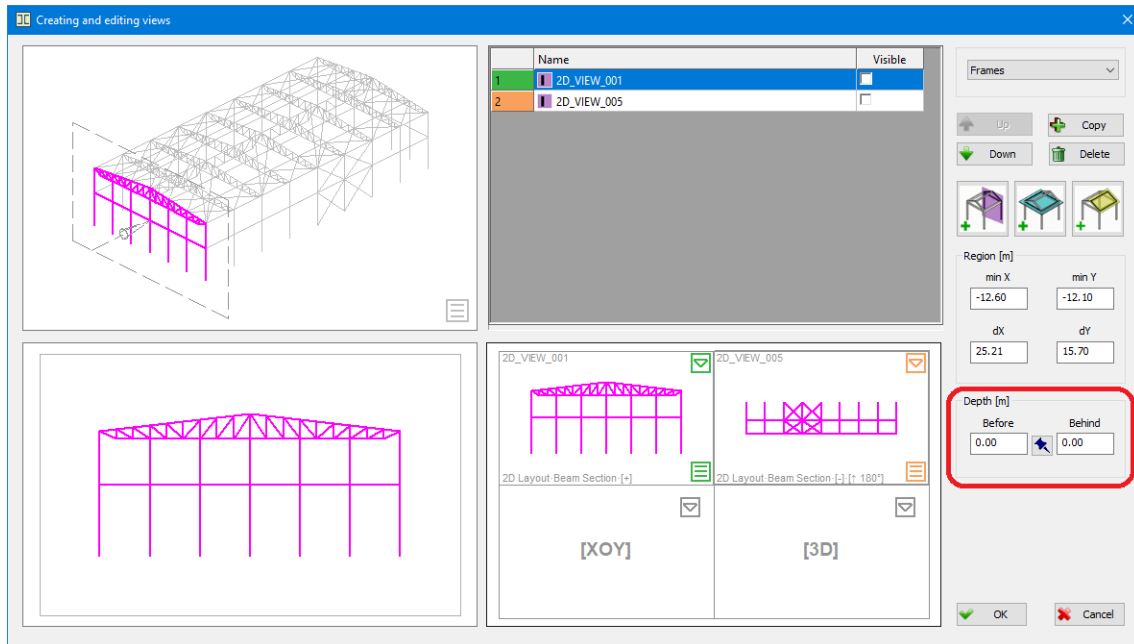

Edit boxes for setting the depth of viewport

Before Edit box in which the value of the depth of view from the front is entered.

Behind Edit box in which the value of the depth of view from the back is entered.

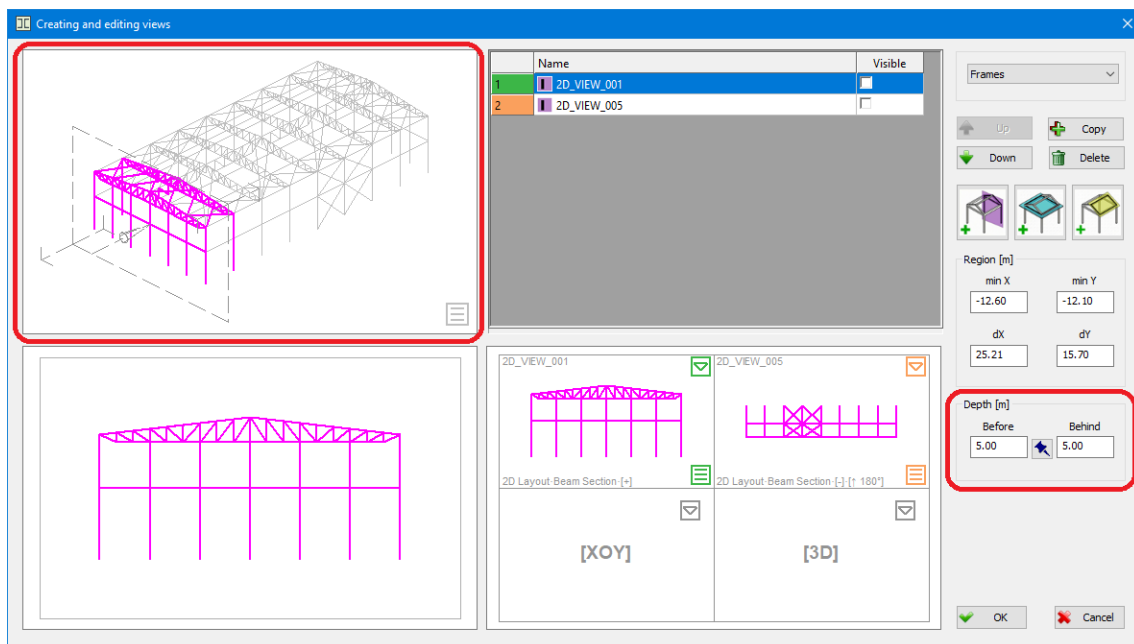

By setting the depth, all entities that enter the defined space will be displayed in the viewport

Please note that it is not possible to make adjustments to viewports, which have been assigned programmatically defined views '3D' and canonical 'XOY'.

Specifying the region of viewport

In the 'Region' part of the dialog, users are enabled to change the viewport region, which is represented by a gray rectangle in the dialog, by setting values in the corresponding edit boxes:

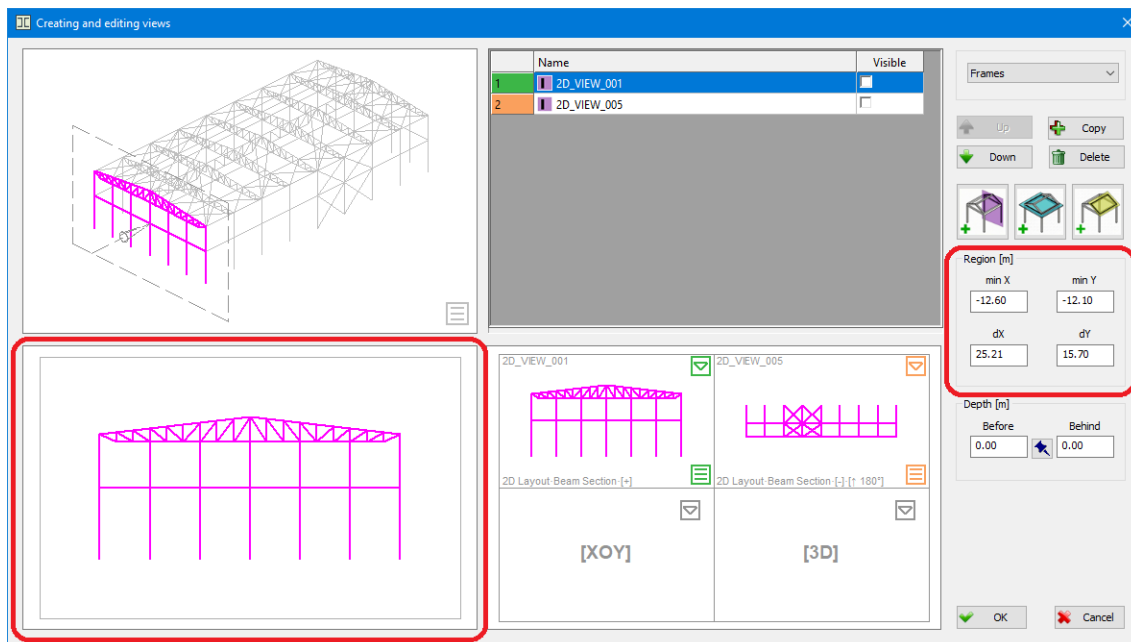

A window reserved for displaying the given region of viewport

min X Edit box for entering the value of at minimum X coordinate of the region of viewport.

min Y Edit box for entering the value of the minimum Y coordinate of the region of viewport.

dX Edit box for entering the length of the region of viewport.

dY Edit box for entering the value of the height of the region of viewport.

The region of viewport can also be adjusted on the drawing itself in the dialog. Changing the region is done by placing the mouse pointer over a segment of the contour of the region and pressing the left mouse button, while that segment changes color to red, which means that it is selected for moving:

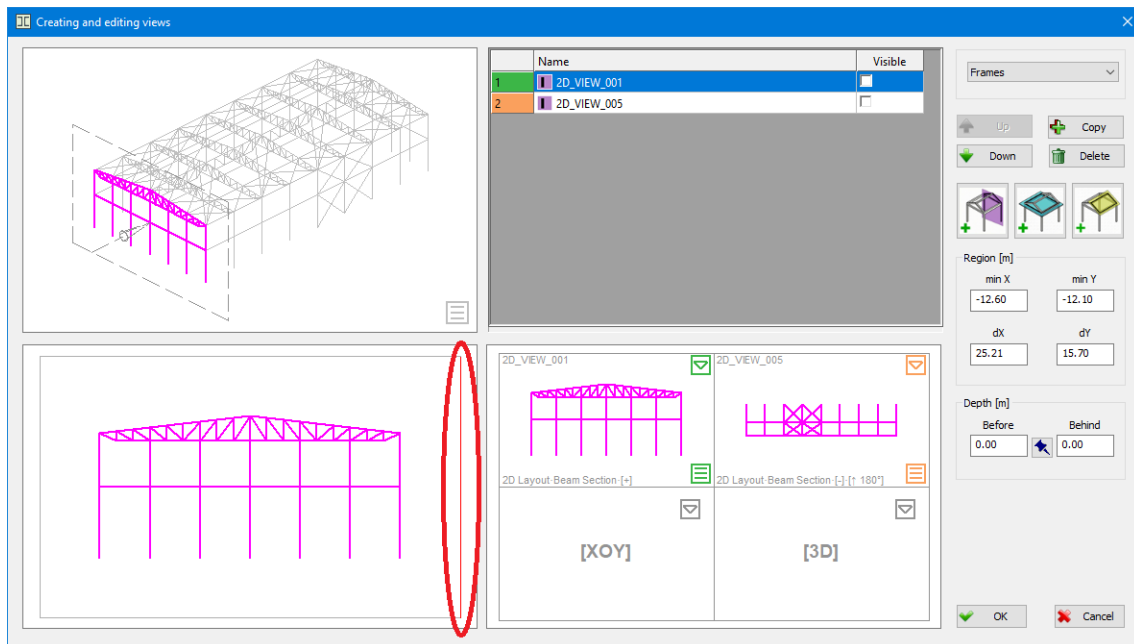

The selected segment for moving is marked in red

The movement itself is very simple, the mouse pointer is placed in the desired place on the drawing and the left mouse button is pressed. The change of the region is immediately visible on the drawing, and the new values of the changed region are displayed in the corresponding edit boxes 'dX' and 'dY'.

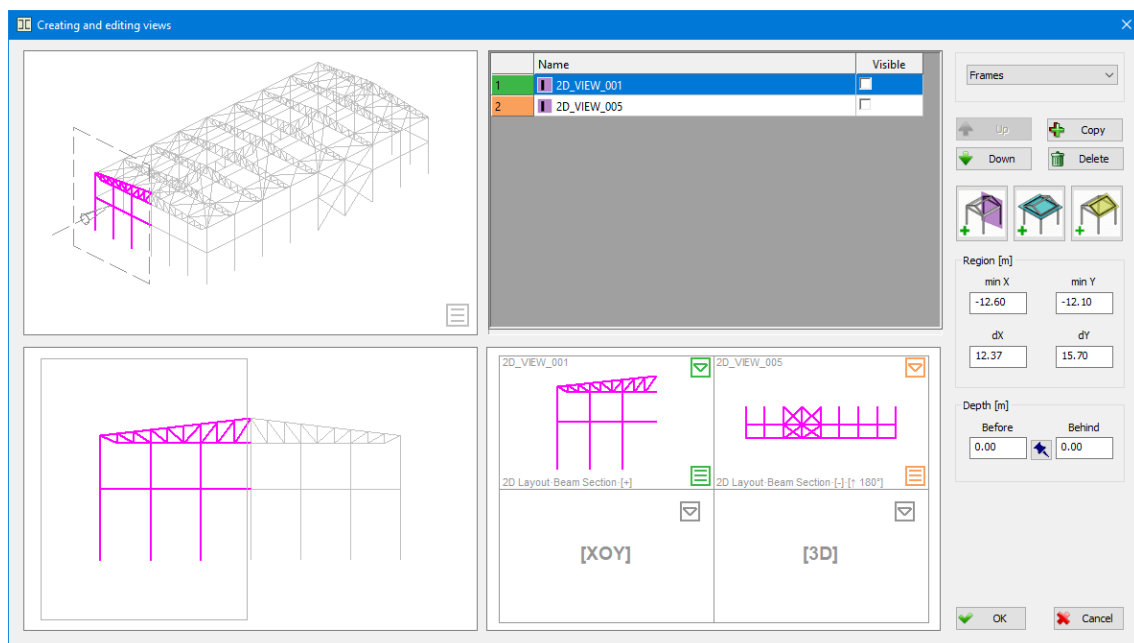

Entities located within the changed region are specially marked on the drawing

By exiting the dialog for creating and editing views with the 'OK' button, the created views with their settings will be placed in the viewports:

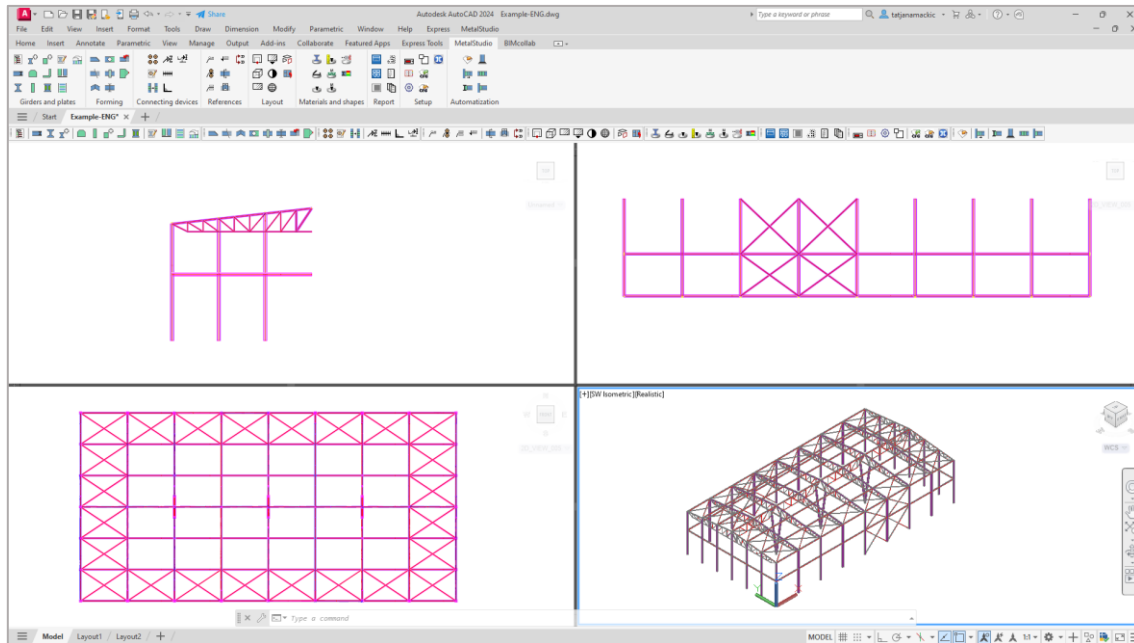

Viewports show set '2D views'

16.4 Limitations of AutoCAD in working with viewports

- ORTHOMODE and Polar Tracking work only in the viewport plane that was active at the time the command was run. This can cause some difficulty when setting points in viewports that become active after running a given command. The most obvious example is when taking sections or details from a frame/ceiling/slanted view and then placing them in a viewport showing the XOY view. It is recommended that in such cases, the angle necessary for their placement is set by entering a value on the command line, and not by selecting a point from the drawing.
- Proxy Entity - Entities created in Metal Studio will not be displayed as 'Proxy Entity' when the drawing containing them is opened in AutoCAD without the presence of Metal Studio, if the drawing is recorded in the '3D Modeling' mode. If you need to send a drawing to someone who does not have the Metal Studio program, it is necessary to record the drawing from the '2D Preparation' program mode, because only then will Entities created in the Metal Studio program be displayed as 'Proxy Entity' when the drawing containing them is opened in the AutoCAD program.

17. SAVE TO METAL STUDIO 1 FORMAT

17.1 Save to Metal Studio 1 format

Drawings created with the Metal Studio 2 program are saved using this command in a format that can also be loaded by the Metal Studio 1 program. A drawing exported in this way, opened in the Metal Studio 1 program, will be identical to the original drawing, except that it will not have all the new details and display options inherent in the Metal Studio 2 program. By selecting the command from the '**Metal Studio**' drop-down menu or by clicking on the icon , a dialog with the following appearance will open:

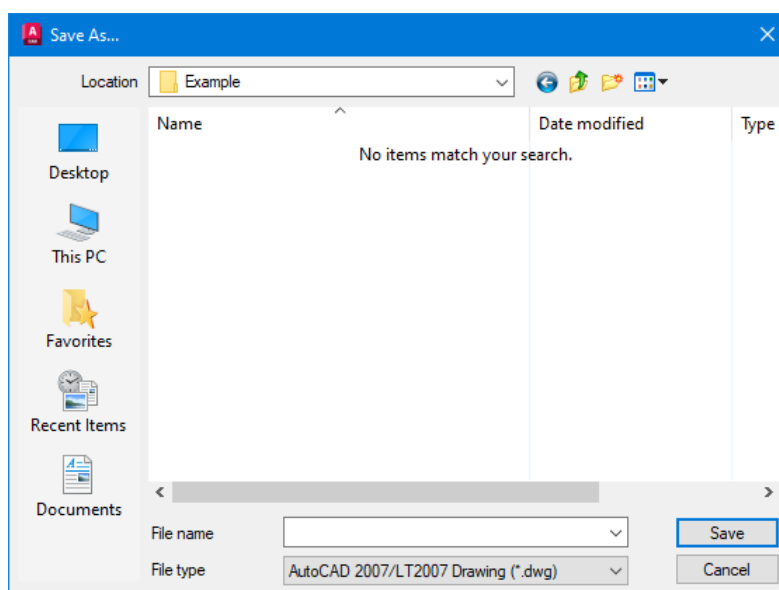

Now you need to choose a place on the computer disk where the drawing will be saved, and then enter a name in the edit box '**File name**'. From the closed list '**File type**', select the oldest version of AutoCAD into which the recorded file can be loaded. Saving the file under the given name is done by activating the '**Save**' button, after which the dialog closes and the command ends.